

## WPLQE

**The right angle planetary gearbox with universal output flange – flexible installation options and for high forces**

The **WPLQE** is our right angle gearbox with the square output flange. This makes it particularly easy to install for a wide range of applications, and its large tapered roller bearings also make it ideal for high radial and axial forces.

### 1 Square output flange

The **WPLQE** can be bolted directly to the machine without the need for additional intermediate flanges.

The output flange with through holes safeguard the ease, reliability, and full accessibility of the installation.

### 2 Optimized ball bearings

Install your drive elements directly on the output shaft at the **WPLQE** – this saves time and money without compromising performance. Thanks to its large tapered roller bearings at the output, this right angle gearbox can also absorb large radial and axial forces.

### 3 Highest installation flexibility

You will get the most out of your gearbox: The **WPLQE** has lifetime lubrication and can be installed virtually anywhere for maximum flexibility.

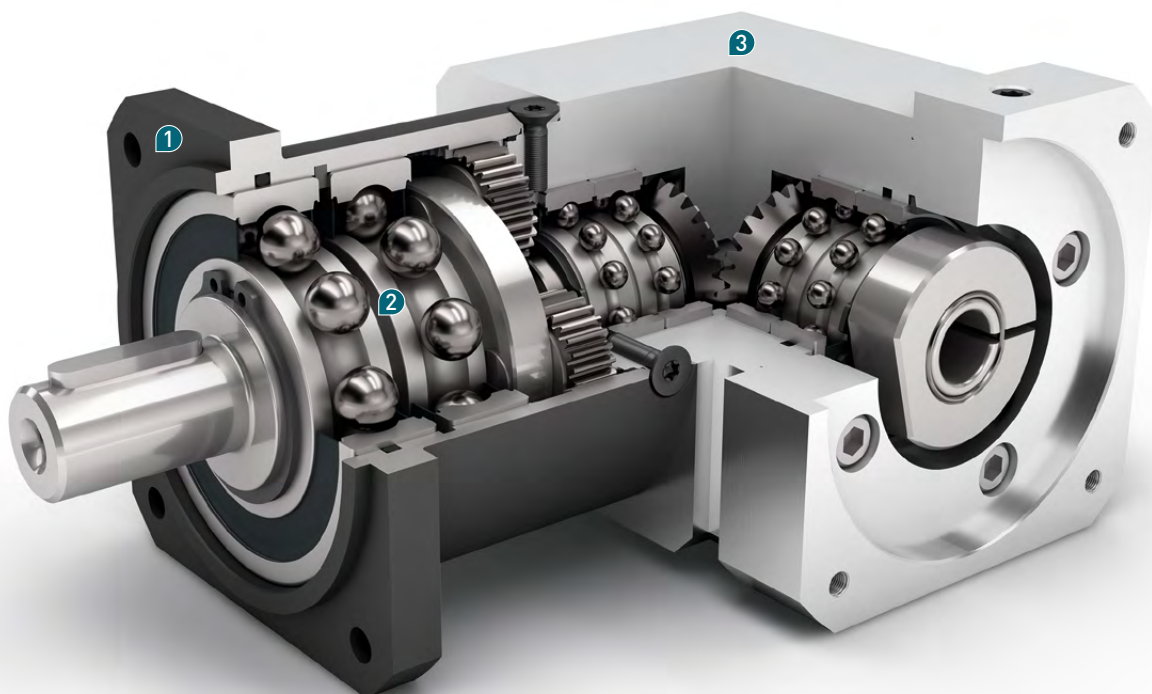

WPLQE

- + Individual adaptation of the input flange to the motor
- + Lifetime lubrication for maintenance-free operation
- + Equidirectional rotation
- + Wide range of output shaft designs
- + Precise gearing
- + Wide range of ratios  $i = 3$  to  $i = 512$

Code	Gearbox characteristics			WPLQE060	WPLQE080	WPLQE120	z <sup>(1)</sup>
	Service life	t <sub>L</sub>	h	20,000			
	Service life at T <sub>2N</sub> x 0.88			30,000			
	Efficiency at full load <sup>(2)</sup>	η	%	95			1
				94			2
				88			3
	Min. operating temperature	T <sub>min</sub>	°C	-25 (-13)			
	Max. operating temperature	T <sub>max</sub>	(°F)	90 (194)			
	Protection class				IP 54		
<b>S</b>	Standard lubrication				Grease		
<b>F</b>	Food grade lubrication				Grease		
<b>L</b>	Low temperature lubrication <sup>(3)</sup>				Grease		
	Installation position				Any		
<b>S</b>	Standard backlash	j <sub>t</sub>	arcmin	< 16	< 13	< 11	1
				< 18	< 15	< 13	2
				< 21	< 17	< 15	3
	Torsional stiffness <sup>(2)</sup>	c <sub>g</sub>	Nm/arcmin (lb <sub>r</sub> .in/ arcmin)	1.6 - 2.1 (14 - 19)	4.7 - 6.3 (42 - 56)	10.1 - 13.6 (89 - 120)	1
				1.7 - 2.1 (15 - 19)	5.1 - 6.3 (45 - 56)	11.0 - 13.6 (97 - 120)	2
				1.6 - 2.1 (14 - 19)	4.9 - 6.3 (43 - 56)	10.5 - 13.6 (93 - 120)	3
	Gearbox weight	m <sub>G</sub>	kg (lb <sub>m</sub> )	1.9 (4.2)	5.5 (12.1)	12.6 (27.8)	1
				2.1 (4.6)	6.1 (13.5)	14.6 (32.2)	2
				2.3 (5.1)	6.6 (14.6)	16.6 (36.6)	3
<b>S</b>	Standard surface				Housing: Steel – nitrocarburized and post-oxidized (black)		
	Running noise <sup>(4)</sup>	Q <sub>g</sub>	dB(A)	70	73	75	
	Max. bending moment based on the gearbox input flange <sup>(5)</sup>	M <sub>b</sub>	Nm (lb <sub>r</sub> .in)	5 (44)	10.5 (93)	26 (230)	
	Motor flange precision				DIN 42955-N		

Output shaft loads			WPLQE060	WPLQE080	WPLQE120	z <sup>(1)</sup>
Radial force for 20,000 h <sup>(6)(7)</sup>	F <sub>r20.000h</sub>	N (lb <sub>r</sub> )	900 (203)	2050 (461)	2950 (664)	
Axial force for 20,000 h <sup>(6)(7)</sup>	F <sub>a20.000h</sub>		1000 (225)	2500 (563)	2500 (563)	
Radial force for 30,000 h <sup>(6)(7)</sup>	F <sub>r30.000h</sub>		700 (158)	1700 (383)	2400 (540)	
Axial force for 30,000 h <sup>(6)(7)</sup>	F <sub>a30.000h</sub>		800 (180)	2000 (450)	2100 (473)	
Static radial force <sup>(7)(8)</sup>	F <sub>rStat</sub>		1500 (338)	2500 (563)	4000 (900)	
Static axial force <sup>(7)(8)</sup>	F <sub>aStat</sub>		1950 (439)	3800 (855)	3800 (855)	
Tilting moment for 20,000 h <sup>(6)(8)</sup>	M <sub>K20.000h</sub>	Nm (lb <sub>r</sub> .in)	37 (327)	101 (894)	232 (2053)	
Tilting moment for 30,000 h <sup>(6)(8)</sup>	M <sub>K30.000h</sub>		29 (257)	84 (743)	188 (1664)	

Moment of inertia			WPLQE060	WPLQE080	WPLQE120	z <sup>(1)</sup>
Mass moment of inertia <sup>(2)</sup>	J	kgcm <sup>2</sup> (lb <sub>r</sub> .in.s <sup>2</sup> 10 <sup>-4</sup> )	0.223 - 0.390 (1.974 - 3.452)	0.928 - 1.538 (8.213 - 13.611)	1.852 - 3.235 (16.390 - 28.630)	1
			0.223 - 0.379 (1.974 - 3.354)	0.932 - 1.438 (8.248 - 12.726)	1.919 - 3.400 (16.983 - 30.090)	2
			0.223 - 0.240 (1.974 - 2.124)	0.931 - 1.368 (8.239 - 12.107)	1.919 - 3.175 (16.983 - 28.099)	3

(1) Number of stages

(2) The ratio-dependent values can be retrieved in Tec Data Finder – www.neugart.com

(3) T<sub>min</sub> = -40°C (-40°F). Optimal operating temperature max. 50°C (122°F)

(4) Sound pressure level from 1 m, measured on input running at n<sub>1</sub>=3000 rpm no load; i=5

(5) Max. motor weight\* in kg = 0.2 x M<sub>g</sub> / motor length in m

\* with symmetrically distributed motor weight

\* with horizontal and stationary mounting

(6) These values are based on an output shaft speed of n<sub>2</sub>=100 rpm

(7) Based on center of output shaft

(8) Other (sometimes higher) values following changes to T<sub>2N</sub>, F<sub>r</sub>, F<sub>a</sub>, cycle, and service life of bearing. Application specific configuration with NCP – www.neugart.com

Output torques			WPLQE060	WPLQE080	WPLQE120	i <sup>(1)</sup>	z <sup>(2)</sup>
Nominal output torque <sup>(3)(4)</sup>	T <sub>2N</sub>	Nm (lb.in)	14 (124)	40 (354) <sup>(5)</sup>	80 (708) <sup>(5)</sup>	3	1
			19 (168)	53 (469) <sup>(5)</sup>	105 (929) <sup>(5)</sup>	4	
			24 (212)	67 (593) <sup>(5)</sup>	130 (1151) <sup>(5)</sup>	5	
			25 (221)	65 (575)	135 (1195)	7	
			18 (159)	50 (443)	120 (1062)	8	
			15 (133)	38 (336)	95 (841)	10	
			44 (389) <sup>(5)</sup>	130 (1151) <sup>(5)</sup>	210 (1859) <sup>(5)</sup>	9	2
			44 (389)	120 (1062) <sup>(5)</sup>	260 (2301) <sup>(5)</sup>	12	
			44 (389)	110 (974)	230 (2036)	15	
			44 (389)	120 (1062)	260 (2301)	16	
			44 (389)	120 (1062)	260 (2301)	20	
			40 (354)	110 (974)	230 (2036)	25	
			44 (389)	120 (1062)	260 (2301)	32	3
			40 (354)	110 (974)	230 (2036)	40	
			18 (159)	50 (443)	120 (1062)	64	
			44 (389)	110 (974)	260 (2301)	60	
			44 (389)	120 (1062)	260 (2301)	80	
			44 (389)	120 (1062)	260 (2301)	100	
			44 (389)	110 (974)	230 (2036)	120	
			44 (389)	120 (1062)	260 (2301)	160	
			40 (354)	110 (974)	230 (2036)	200	
			44 (389)	120 (1062)	260 (2301)	256	
			40 (354)	110 (974)	230 (2036)	320	
			18 (159)	50 (443)	120 (1062)	512	
Max. output torque <sup>(4)(6)</sup>	T <sub>2max</sub>	Nm (lb.in)	22 (195)	64 (566)	128 (1133)	3	1
			30 (266)	85 (752)	168 (1487)	4	
			38 (336)	107 (947)	208 (1841)	5	
			40 (354)	104 (920)	216 (1912)	7	
			29 (257)	80 (708)	192 (1699)	8	
			24 (212)	61 (540)	152 (1345)	10	
			70 (620)	208 (1841)	336 (2974)	9	2
			70 (620)	192 (1699)	416 (3682)	12	
			70 (620)	176 (1558)	368 (3257)	15	
			70 (620)	192 (1699)	416 (3682)	16	
			70 (620)	192 (1699)	416 (3682)	20	
			64 (566)	176 (1558)	368 (3257)	25	
			70 (620)	192 (1699)	416 (3682)	32	3
			64 (566)	176 (1558)	368 (3257)	40	
			29 (257)	80 (708)	192 (1699)	64	
			70 (620)	176 (1558)	416 (3682)	60	
			70 (620)	192 (1699)	416 (3682)	80	
			70 (620)	192 (1699)	416 (3682)	100	
			70 (620)	176 (1558)	368 (3257)	120	
			70 (620)	192 (1699)	416 (3682)	160	
			64 (566)	176 (1558)	368 (3257)	200	
			70 (620)	192 (1699)	416 (3682)	256	
			64 (566)	176 (1558)	368 (3257)	320	
			29 (257)	80 (708)	192 (1699)	512	

WPLQE

(1) Ratios (i=n<sub>1</sub>/n<sub>2</sub>)  
 (2) Number of stages  
 (3) Application specific configuration with NCP – www.neugart.com  
 (4) Values for feather key (code "A"): for repeated load  
 (5) Different service life: 10,000 h at T<sub>2N</sub>  
 (6) 30,000 rotations of the output shaft permitted; see page 128

Output torques			WPLQE060	WPLQE080	WPLQE120	i <sup>(1)</sup>	z <sup>(2)</sup>
Emergency stop torque <sup>(3)</sup>	T <sub>2Stop</sub>	Nm (lb <sub>r</sub> .in)	66 (584)	180 (1593)	360 (3186)	3	1
			86 (761)	240 (2124)	474 (4195)	4	
			80 (708)	220 (1947)	500 (4425)	5	
			80 (708)	178 (1575)	340 (3009)	7	
			80 (708)	190 (1682)	380 (3363)	8	
			70 (620)	170 (1505)	430 (3806)	10	
			88 (779)	260 (2301)	500 (4425)	9	2
			88 (779)	240 (2124)	520 (4602)	12	
			88 (779)	220 (1947)	500 (4425)	15	
			88 (779)	240 (2124)	520 (4602)	16	
			88 (779)	240 (2124)	520 (4602)	20	
			80 (708)	220 (1947)	500 (4425)	25	
			88 (779)	240 (2124)	520 (4602)	32	3
			80 (708)	220 (1947)	500 (4425)	40	
			80 (708)	190 (1682)	380 (3363)	64	
			88 (779)	220 (1947)	520 (4602)	60	
			88 (779)	240 (2124)	520 (4602)	80	
			88 (779)	240 (2124)	520 (4602)	100	
			88 (779)	220 (1947)	500 (4425)	120	3
			88 (779)	240 (2124)	520 (4602)	160	
			80 (708)	220 (1947)	500 (4425)	200	
			88 (779)	240 (2124)	520 (4602)	256	
			80 (708)	220 (1947)	500 (4425)	320	
			80 (708)	190 (1682)	380 (3363)	512	

Input speeds			WPLQE060	WPLQE080	WPLQE120	i <sup>(1)</sup>	z <sup>(2)</sup>
Average thermal input speed at T <sub>2N</sub> and S1 <sup>(4)(5)</sup>	n <sub>1N</sub>	rpm	4500 <sup>(6)</sup>	3100 <sup>(6)</sup>	2850 <sup>(6)</sup>	3	1
			4500 <sup>(6)</sup>	3250 <sup>(6)</sup>	2950 <sup>(6)</sup>	4	
			4500 <sup>(6)</sup>	3350 <sup>(6)</sup>	3050 <sup>(6)</sup>	5	
			4500	4000 <sup>(6)</sup>	3500 <sup>(6)</sup>	7	
			4500	4000 <sup>(6)</sup>	3500 <sup>(6)</sup>	8	
			4500	4000	3500	10	
			4500 <sup>(6)</sup>	3150 <sup>(6)</sup>	2950 <sup>(6)</sup>	9	2
			4500 <sup>(6)</sup>	3750 <sup>(6)</sup>	3050 <sup>(6)</sup>	12	
			4500	4000 <sup>(6)</sup>	3500 <sup>(6)</sup>	15	
			4500	4000 <sup>(6)</sup>	3450 <sup>(6)</sup>	16	
			4500	4000 <sup>(6)</sup>	3500 <sup>(6)</sup>	20	
			4500	4000	3500 <sup>(6)</sup>	25	
			4500	4000	3500	32	3
			4500	4000	3500	40	
			4500	4000	3500	64	
			4500	4000	3500	60	
			4500	4000	3500	80	
			4500	4000	3500	100	
			4500	4000	3500	120	3
			4500	4000	3500	160	
			4500	4000	3500	200	
			4500	4000	3500	256	
			4500	4000	3500	320	
			4500	4000	3500	512	
Max. mechanical input speed <sup>(4)</sup>	n <sub>1Limit</sub>	rpm	13000	7000	6500		

(1) Ratios (i=n<sub>1</sub>/n<sub>2</sub>)  
 (2) Number of stages  
 (3) Permitted 1000 times  
 (4) Application-specific speed configurations with NCP – www.neugart.com  
 (5) See page 128 for the definition  
 (6) Average thermal input speed at 50% T<sub>2N</sub> and S1

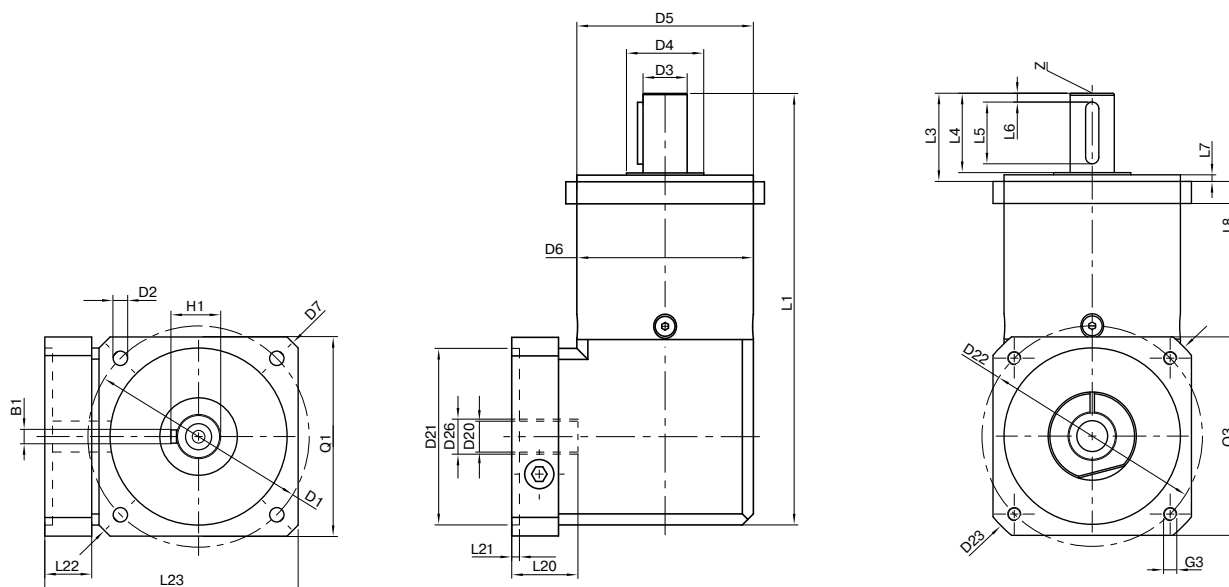

Drawing corresponds to a WPLQE080 / 1-stage / output shaft with feather key / 19 mm clamping system / motor adaptation – 2-part – square universal flange / B5 flange type motor  
 All other variants can be retrieved in Tec Data Finder at [www.neugart.com](http://www.neugart.com)

Geometry <sup>(1)</sup>			WPLQE060	WPLQE080	WPLQE120	z <sup>(2)</sup>	Code
Pitch circle diameter output	D1		75 (2.953)	100 (3.937)	130 (5.118)		
Mounting bore output	D2	4x	5.5 (0.217)	6.5 (0.256)	8.5 (0.335)		
Shaft diameter output	D3	h7	16 (0.630)	20 (0.787)	25 (0.984)		
Shaft collar output	D4		20 (0.787)	35 (1.378)	35 (1.378)		
Centering diameter output	D5	h7	60 (2.362)	80 (3.150)	110 (4.331)		
Housing diameter	D6		60 (2.362)	80 (3.150)	115 (4.528)		
Diagonal dimension output	D7		92 (3.622)	116 (4.567)	145 (5.709)		
Flange cross section output	Q1	■	70 (2.756)	90 (3.543)	115 (4.528)		
Total length	L1		152 (5.984)	195.5 (7.697)	274.5 (10.807)	1	
			164.5 (6.476)	213 (8.386)	302.5 (11.909)	2	
			177 (6.968)	230.5 (9.075)	330 (12.992)	3	
Shaft length output	L3		32 (1.260)	40 (1.575)	55 (2.165)		
Centering depth output	L7		3 (0.118)	3 (0.118)	4 (0.157)		
Flange thickness output	L8		10 (0.394)	10 (0.394)	15 (0.591)		
Min. overall height	L23		91 (3.563)	115 (4.528)	146 (5.728)		
Clamping system diameter input	D26		More information on page 117				
Motor shaft diameter j6/k6	D20		The dimensions vary with the motor/gearbox flange. The input flange geometries can be retrieved for each specific motor in Tec Data Finder at <a href="http://www.neugart.com">www.neugart.com</a>				
Max. permis. motor shaft length	L20						
Min. permis. motor shaft length							
Centering diameter input	D21						
Centering depth input	L21						
Pitch circle diameter input	D22						
Motor flange length	L22						
Diagonal dimension input	D23						
Mounting thread x depth	G3	4x					
Flange cross section input	Q3	■					
Output shaft with feather key (DIN 6885-1)			A 5x5x20	A 6x6x28	A 8x7x40		A
Feather key width (DIN 6885-1)	B1		5 (0.197)	6 (0.236)	8 (0.315)		
Shaft height including feather key (DIN 6885-1)	H1		18 (0.709)	22.5 (0.886)	28 (1.102)		
Shaft length from shoulder	L4		28 (1.102)	36 (1.417)	50 (1.969)		
Feather key length	L5		20 (0.787)	28 (1.102)	40 (1.575)		
Distance from shaft end	L6		4 (0.157)	4 (0.157)	5 (0.197)		
Center hole (DIN 332, type DR)	Z		M5x12.5	M6x16	M10x22		
Smooth output shaft							B
Shaft length from shoulder	L4		28 (1.102)	36 (1.417)	50 (1.969)		

<sup>(1)</sup> Dimensions in mm (in)

<sup>(2)</sup> Number of stages