

SIEMENS

SIMOTION

SIMOTION C

Operating Instructions

Preface	
Description	1
Operator control (hardware)	2
Interfaces	3
Configuring and installing	4
Connecting	5
Addressing	6
Commissioning	7
Maintenance and servicing	8
Alarm, error, and system messages	9
Technical data	10
Dimension drawing, spare parts, and accessories	11
Standards, Certificates and Approvals	A
ESD guidelines	B

Valid for SIMOTION C230-2, C240 and C240 PN

Legal information

Warning notice system

This manual contains notices you have to observe in order to ensure your personal safety, as well as to prevent damage to property. The notices referring to your personal safety are highlighted in the manual by a safety alert symbol, notices referring only to property damage have no safety alert symbol. These notices shown below are graded according to the degree of danger.

 DANGER
indicates that death or severe personal injury will result if proper precautions are not taken.

 WARNING
indicates that death or severe personal injury may result if proper precautions are not taken.

 CAUTION
with a safety alert symbol, indicates that minor personal injury can result if proper precautions are not taken.

CAUTION
without a safety alert symbol, indicates that property damage can result if proper precautions are not taken.

NOTICE
indicates that an unintended result or situation can occur if the relevant information is not taken into account.

If more than one degree of danger is present, the warning notice representing the highest degree of danger will be used. A notice warning of injury to persons with a safety alert symbol may also include a warning relating to property damage.

Qualified Personnel

The product/system described in this documentation may be operated only by **personnel qualified** for the specific task in accordance with the relevant documentation, in particular its warning notices and safety instructions. Qualified personnel are those who, based on their training and experience, are capable of identifying risks and avoiding potential hazards when working with these products/systems.

Proper use of Siemens products

Note the following:

 WARNING
Siemens products may only be used for the applications described in the catalog and in the relevant technical documentation. If products and components from other manufacturers are used, these must be recommended or approved by Siemens. Proper transport, storage, installation, assembly, commissioning, operation and maintenance are required to ensure that the products operate safely and without any problems. The permissible ambient conditions must be complied with. The information in the relevant documentation must be observed.

Trademarks

All names identified by ® are registered trademarks of Siemens AG. The remaining trademarks in this publication may be trademarks whose use by third parties for their own purposes could violate the rights of the owner.

Disclaimer of Liability

We have reviewed the contents of this publication to ensure consistency with the hardware and software described. Since variance cannot be precluded entirely, we cannot guarantee full consistency. However, the information in this publication is reviewed regularly and any necessary corrections are included in subsequent editions.

Preface

Contents of manual

This document is part of the SIMOTION C documentation package.

Sections in this manual

The following is a list of sections included in this manual along with a description of the information presented in each section.

- Description
This section explains the purpose and potential applications of the module.
- Operation (hardware)
This section describes the operator controls and how they are operated.
- Interfaces
This section includes a description of the interfaces and their functions.
- Installing
This section explains how to configure the mechanical design and how to install the SIMOTION C components.
- Connecting
This section describes the wiring and networking of SIMOTION C.
- Addressing
This section contains the information you will require to define the module start addresses for the modules you are using.
- Commissioning (hardware)
This section describes how you commission the hardware components and what you must take into account.
- Service and maintenance
This section describes how you replace the module and update the SIMOTION Kernel.
- Interrupt, error and system alarms
This section provides information about the causes of alarms and the corrective actions you must take.
- Technical data
This section describes the properties and features of the SIMOTION C.
- Dimension drawing
This section contains the dimension drawing of SIMOTION C.

- Spare parts/accessories
This section provides information on accessories and spare parts for SIMOTION C.
- Appendices with factual information for reference (for example, Standards and approvals, ESD, etc.)
- Index to locate information

Standards and approvals

Our products meet the requirements of EU Directive 89/336/EEC Electromagnetic Compatibility and the harmonized European Standards (EN) listed there.

You can find detailed information on approvals and standards in the appendix.

The current Declaration of Conformity is on the Internet at

<http://support.automation.siemens.com/WW/view/de/15257461>

SIMOTION Documentation

An overview of the SIMOTION documentation can be found in a separate list of references.

This documentation is included as electronic documentation in the scope of delivery of SIMOTION SCOUT. It comprises 10 documentation packages.

The following documentation packages are available for SIMOTION V4.3:

- SIMOTION Engineering System
- SIMOTION System and Function Descriptions
- SIMOTION Service and Diagnostics
- SIMOTION IT
- SIMOTION Programming
- SIMOTION Programming - References
- SIMOTION C
- SIMOTION P
- SIMOTION D
- SIMOTION Supplementary Documentation

Additional information

Click the following link to find information on the the following topics:

- Ordering documentation/overview of documentation
- Additional links to download documents
- Using documentation online (find and search in manuals/information)

<http://www.siemens.com/motioncontrol/docu>

Please send any questions about the technical documentation (e.g. suggestions for improvement, corrections) to the following e-mail address:
docu.motioncontrol@siemens.com

My Documentation Manager

Click the following link for information on how to compile documentation individually on the basis of Siemens content and how to adapt this for the purpose of your own machine documentation:

<http://www.siemens.com/mdm>

Training

Click the following link for information on SITRAIN - Siemens training courses for automation products, systems and solutions:

<http://www.siemens.com/sitrain>

FAQs

Frequently Asked Questions can be found in SIMOTION Utilities & Applications, which are included in the scope of delivery of SIMOTION SCOUT, and in the Service&Support pages in **Product Support**:

<http://support.automation.siemens.com>

Technical support

Country-specific telephone numbers for technical support are provided on the Internet under **Contact**:

<http://www.siemens.com/automation/service&support>

Product disposal

SIMOTION C is an environmentally friendly product. It includes the following features:

- In spite of its excellent resistance to fire, the flame-resistant agent in the plastic used for the housing does not contain halogens.
- Marking of the plastic materials as per ISO 11469.
- Less material used because the unit is smaller and with fewer components thanks to integration in ASICs.

The product is to be disposed of in accordance with national regulations.

The product described in this manual can be recycled owing to its low pollutant content. To recycle and dispose of your old device in an environmentally friendly way, please contact a company that specializes in electronic waste.

Table of contents

	Preface	3
1	Description	11
1.1	System overview	11
1.2	I/O modules approved for SIMOTION	18
1.3	The fundamentals of motion control	20
1.4	Layout of the module	24
1.5	Nameplate.....	27
1.6	Versions of SIMOTION C.....	29
2	Operator control (hardware)	31
2.1	Control Elements	31
2.1.1	Mode selector.....	31
2.1.2	Micro Memory Card (MMC)	32
2.2	Display elements.....	34
3	Interfaces	35
3.1	SIMOTION C interfaces	35
3.2	Ethernet interface.....	36
3.3	PROFINET interface (C240 PN).....	39
3.4	PROFIBUS DP interfaces	42
3.5	Onboard drive interface (C230-2, C240)	45
3.6	Onboard measuring system interface (C230-2, C240).....	52
3.7	Possible uses of onboard drive and measuring system interface in the application (C230-2, C240)	63
3.7.1	Overview	63
3.7.2	Configuration examples for C240:	65
3.8	I/O interface.....	68
4	Configuring and installing	77
4.1	General requirements	77
4.2	Configuring an installation using SIMOTION C modules.....	78
4.2.1	Horizontal and vertical configuration.....	78
4.2.2	Clearances	79
4.2.3	Mounting dimensions of modules	80
4.2.4	Layout of modules on a rack.....	81
4.2.5	Layout of modules on several racks	82

4.3	Installing	84
4.3.1	Installing mounting rails.....	84
4.3.2	Fitting modules on the mounting rail	87
4.3.3	After installation.....	88
5	Connecting	91
5.1	Wiring	91
5.1.1	General requirements for wiring.....	91
5.1.2	Configuring the electrical installation	92
5.1.3	Overview of wiring diagram.....	94
5.1.4	Connecting the power supply	100
5.1.5	Connecting the drive units.....	103
5.1.6	Connecting the encoders (C230-2, C240)	114
5.1.7	Wiring the front connector	117
5.1.8	Connecting shielded cables via a shield connecting element.....	120
5.2	Networking	122
5.2.1	Configuring	122
5.2.2	Configuring a PROFIBUS subnet	122
5.2.3	Network components for a PROFIBUS subnet.....	125
5.2.4	Configuring an Ethernet subnet on the Ethernet interface.....	127
5.2.5	Configuring an Ethernet subnet on the PROFINET interface (C240 PN).....	129
5.2.6	Factory setting.....	131
5.2.7	MPI subnet	131
6	Addressing.....	133
6.1	Slot-oriented address allocation for modules (default addresses for centralized I/O)	133
6.2	User-assignable addressing on the SIMOTION C (centralized and distributed I/O)	135
6.3	Addressing signal modules	136
6.4	Addressing the onboard digital inputs and outputs of the SIMOTION C	139
6.5	Addressing the onboard drive and measuring system interface of the C230-2, C240	140
7	Commissioning	143
7.1	Requirements for commissioning.....	143
7.2	Inserting and changing the Micro Memory Card.....	145
7.3	Initial Power ON	146
7.4	Writing, formatting and erasing the Micro Memory Card	147
7.5	User memory concept.....	149
7.5.1	SIMOTION C memory model.....	149
7.5.2	Properties of the user memory.....	150
7.5.3	Operations and their effect on the user memory.....	152
7.6	Deleting data	154
7.6.1	Overview of data deletion.....	154
7.6.2	SIMOTION C memory reset.....	154
7.6.3	Deleting user data from Micro Memory Card	157
7.6.4	Setting SIMOTION C to factory settings	158

8	Maintenance and servicing	159
8.1	SIMOTION kernel update	159
8.1.1	Kernel update for SIMOTION C230-2.....	159
8.1.2	Kernel update for SIMOTION C240 / C240 PN	161
8.2	Removal and replacement of the SIMOTION C	162
8.3	Module replacement without programming device or PC	163
9	Alarm, error, and system messages	165
9.1	Diagnosis using the LEDs.....	165
9.2	Combinations of LED displays.....	169
10	Technical data	171
10.1	Technical data.....	171
10.2	Real-time clock.....	179
10.3	Transportation and storage conditions for SIMOTION C.....	179
10.4	Mechanical and climatic environmental conditions for operation of the SIMOTION C.....	180
10.5	Specifications for dielectric tests, safety class and degree of protection	182
11	Dimension drawing, spare parts, and accessories	183
11.1	Dimension drawing	183
11.2	Spare parts and accessories	184
A	Standards, Certificates and Approvals	185
A.1	General rules.....	185
A.2	Safety of electronic controllers.....	187
B	ESD guidelines	189
B.1	ESD definition	189
B.2	Electrostatic charging of individuals.....	190
B.3	Basic measures for protection against discharge of static electricity	191
	Index	193

Description

1.1 System overview

	C230-2	C240	C240 PN
Mode selector	Rotary switch	Toggle switch	Toggle switch
Error and status displays	X	X	X
Memory module slot for micro memory card	32 MB	64 MB	64 MB
I/O interface X1	X	X	X
Drive interface X2	X	X	-
Measuring system interface X3 - X6	X	X	-
Ethernet interface X7	X	X	X
PROFIBUS DP1 interface X8	X	X	X
PROFIBUS DP2/MPI interface X9	X	X	X
Power supply X10	X	X	X
PROFINET interface X11	-	-	X11 P1 X11 P2 X11 P3
Bus connector for I/O BUS	X	X	X
Diagnostics LED for Ethernet	-	-	X
Diagnostics LED for PROFINET	-	-	X

What capabilities does the SIMOTION C have?

The SIMOTION C is a motion control module for the control of servo drives.

As of V3.2, stepper drives with a pulse-direction interface can be connected to the onboard drive interfaces.

The following configurations can be selected:

- C230-2 and C240: Up to four axes via the onboard drive interface or
- C230-2, C240 and C240 PN: Axes via PROFIBUS DP or
- C240 PN: Axes via PROFINET IO or
- Mixed operation with a maximum of four axes via the onboard drive interface (C230-2, C240) and additional axes via PROFIBUS DP

The number of operable axes on the PROFIBUS DP or PROFINET IO depends on the system cycle clock settings, i.e. more axes can be operated with longer cycle times.

The SIMOTION C controllers are powerful modules for positioning independent single axes or motions in an axis grouping.

Both rotary axes and linear axes can be operated.

The SIMOTION SCOUT engineering system (ES) is used to configure, parameterize, commission, program perform diagnostics for the SIMOTION C.

Where can the SIMOTION C be used?

The C230-2, C240 and C240 PN can be used both for positioning and synchronous operation (gearing, camming and path interpolation).

Typical areas in which the motion control module can be used are:

- Packaging industry
- Plastics industry
- Presses
- Textiles
- Printing industry
- Wood, glass, ceramic, stone

System integration

SIMOTION offers an optimized system platform for automation and drive solutions where priority is given to motion control applications and technological tasks.

The SIMOTION modular system consists of the SIMOTION SCOUT engineering system and a common runtime system for various hardware platforms.

The truly innovative aspect of SIMOTION is that it does away with the traditional separation between pure automation functions and motion functions.

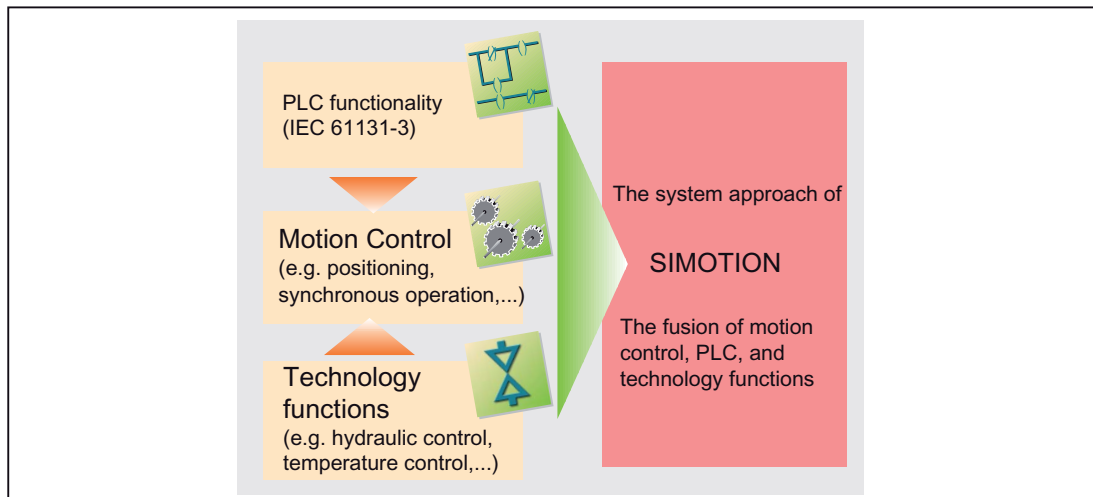

Figure 1-1 System solution for production machines

SIMOTION can be used with all machines with motion control tasks. The focus is on a simple and flexible solution to a wide variety of motion control tasks. In order to achieve this in the best way possible, a new system approach has been introduced:

Motion control has been combined with two other open-loop control functions found in most machines: PLC and technology functions.

This approach enables the motion control of axes and machine control within the same system. The same applies to technology functions, such as pressure control of a hydraulic axis. A seamless switch can be made from position-controlled positioning mode to pressure control.

Combining the three open-loop control functions of motion control, PLC and technology functions has the following benefits:

- Reduced engineering overhead and increased machine performance
- Time-critical interfaces between the individual components are no longer required
- Simple, uniform and transparent programming and diagnostics of the entire machine

The following figures show system configurations with SIMOTION C230-2, C240 and C240 PN.

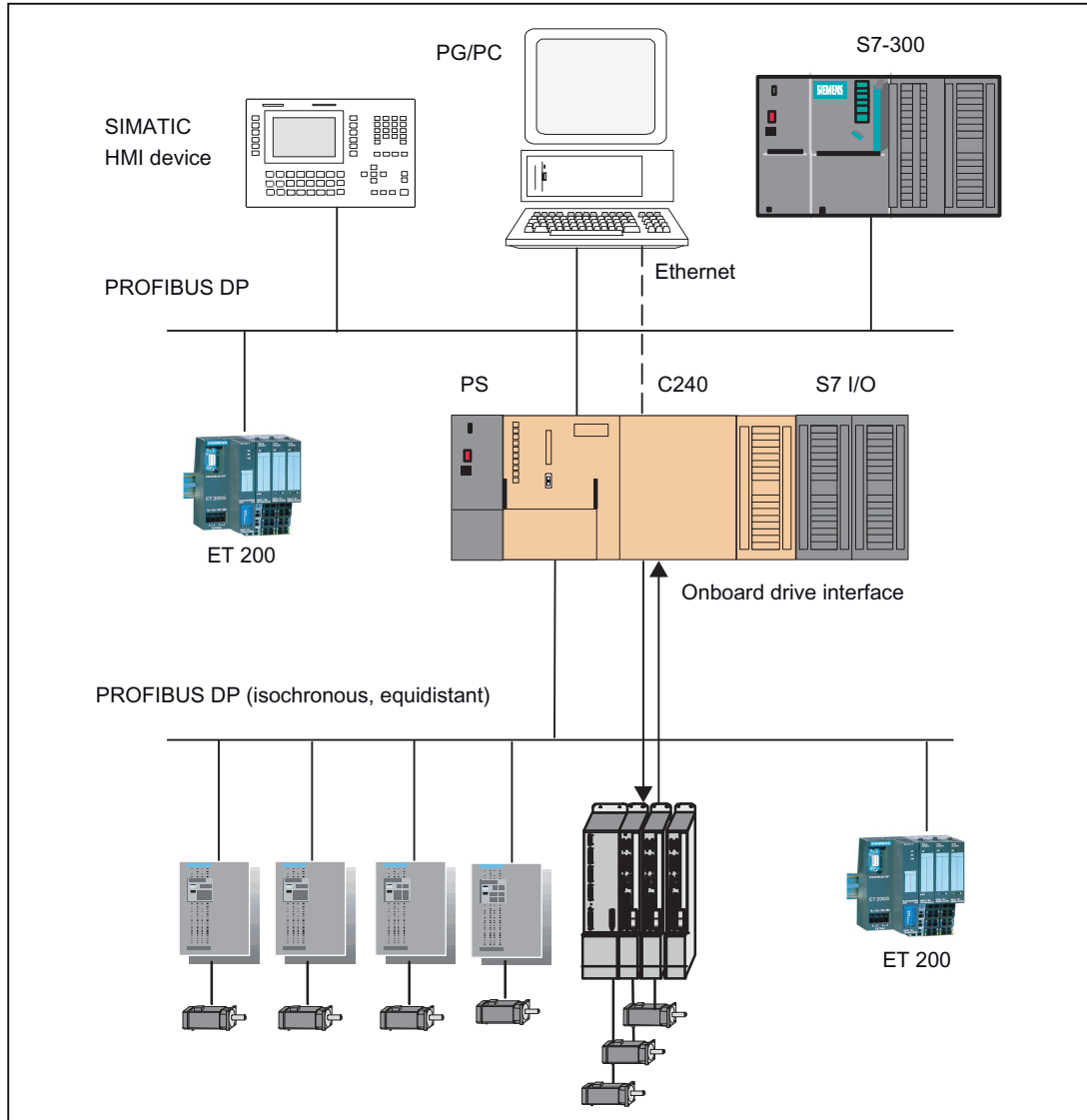

Figure 1-2 System overview of C240

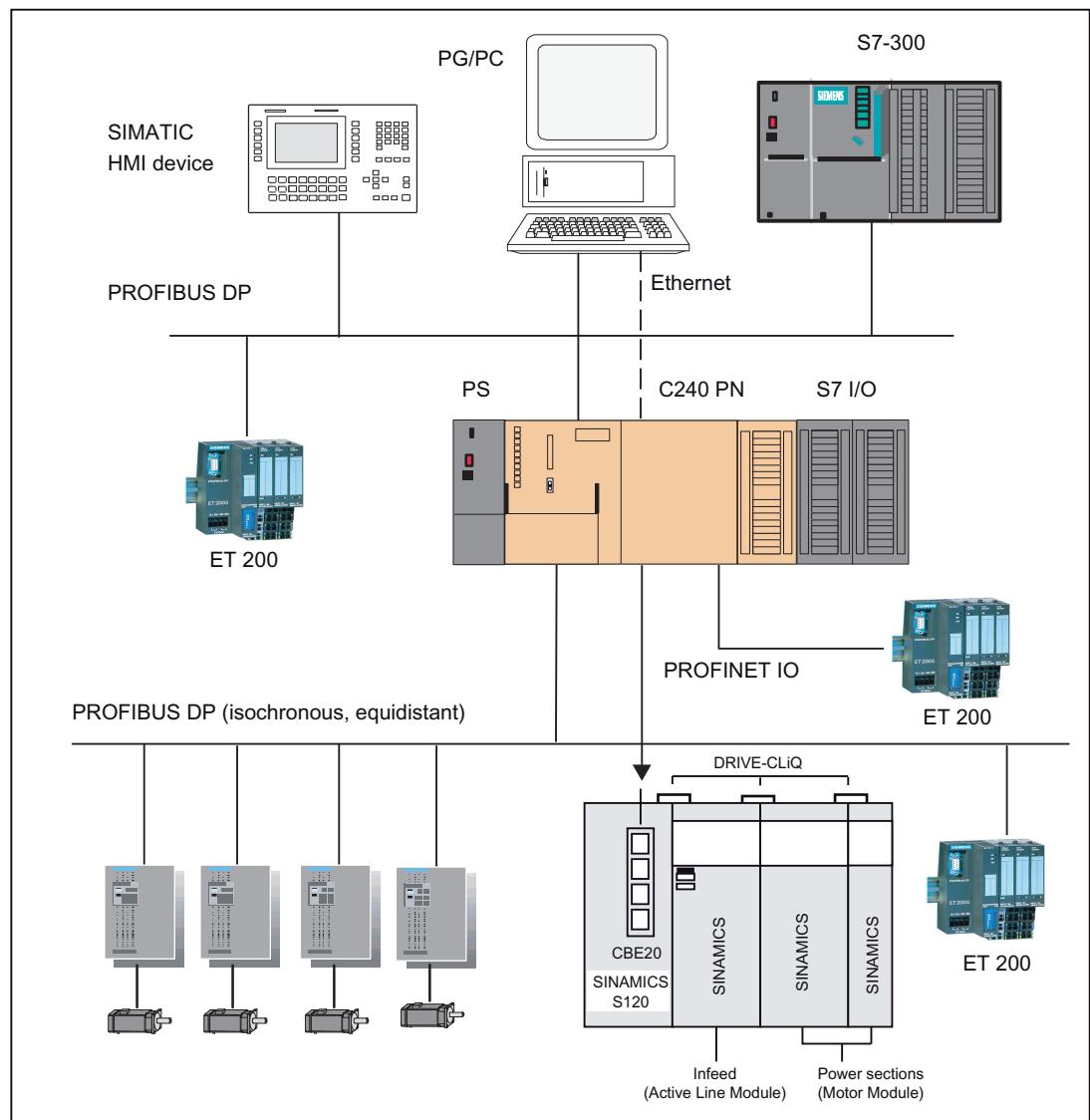

Figure 1-3 System overview of C240 PN

Components

The most important components of a SIMOTION application with SIMOTION C and their functions are listed below.

Note

The modules and devices approved for the SIMOTION C are listed in the *SIMOTION PM 21 Catalog*. This document is supplied in electronic format with SIMOTION SCOUT.

Centralized I/O

Table 1- 1 SIMOTION C with centralized I/O

Component	Function
SIMOTION C	<p>... is the motion control module. The SIMOTION C supplies the I/O bus with 5 V; communicates over the I/O bus (backplane bus) with the I/O modules.</p> <p>You can use the integrated fast digital inputs of the SIMOTION C as:</p> <ul style="list-style-type: none"> • B1 to B4: As homing inputs (C230-2, C240) • M1 and M2: As inputs for measuring inputs - local measuring (C230-2, C240) • B1 to B4: As inputs for global measuring (C240, C240 PN) • Freely addressable process inputs <p>You can use the integrated fast digital outputs as:</p> <ul style="list-style-type: none"> • Fast output cams • Freely addressable process outputs <p>Drive units with a ± 10 V analog interface or stepper drives with a pulse/direction interface can be connected to the onboard drive interface (C230-2, C240). With the C240, the analog interfaces can also be used as available process outputs.</p> <p>Incremental encoders or absolute encoders can be connected to the measuring system interface (C230-2, C240). With the C240, free remaining encoder inputs of an axis channel can be used as the input for a 16-bit up/down counter.</p>
Power supply (PS)	... converts the line voltage (120/230 V AC) into an operating voltage of 24 V DC to supply the SIMOTION C.
Signal modules (SM)	<p>... adapt various process signal levels to the SIMOTION C (digital input/digital output modules and analog input/analog output modules).</p> <p>Note: All approved modules are listed in the <i>PM 21</i> Catalog and in chapter I/O modules approved for SIMOTION (Page 18).</p>
Function modules (FM)	<p>... relieve the CPU of computation-intensive tasks, for example, counting.</p> <p>Note: All approved modules are listed in the <i>PM 21</i> Catalog and in chapter I/O modules approved for SIMOTION (Page 18).</p>
Communications processors (CP)	<p>... for data exchange</p> <p>Note: All approved modules are listed in the <i>PM 21</i> Catalog and in chapter I/O modules approved for SIMOTION (Page 18).</p>

Distributed I/O

Table 1- 2 SIMOTION C with distributed I/O

Component	Function
SIMOTION C	<p>... is the motion control module.</p> <ul style="list-style-type: none"> • Communicates via two PROFIBUS DP interfaces with: <ul style="list-style-type: none"> – Programming device (PG/PC) – SIMATIC HMI devices – SIMATIC S7 controllers with PROFIBUS DP interface – SIMATIC ET 200 I/O systems – Drive units – Other SIMOTION controllers • Communicates via an Ethernet interface with the programming device (PG/PC) • The C240 PN also communicates via the PROFINET IO interface with: <ul style="list-style-type: none"> – Programming device (PG/PC) via Ethernet – SIMATIC HMI devices – SIMATIC S7 controllers with PROFINET IO interface – SIMATIC ET 200 I/O systems with PROFINET IO interface – Drive units – Other SIMOTION controllers <p>Note: All approved devices are listed in the <i>PM 21</i> Catalog and in chapter I/O modules approved for SIMOTION (Page 18).</p>

Table 1- 3 Further components that can be connected to the SIMOTION C

Component	Function
Programming device (PG/PC)	... configures, parameterizes, programs and tests SIMOTION.
SIMATIC HMI device	<p>... is used for operator control and monitoring functions. It is not an essential requirement for the operation of a SIMOTION C.</p> <p>Note: All approved devices are listed in the <i>PM 21</i> Catalog.</p>
Drive units	<p>... convert speed setpoints into signals for controlling the motor and supply the power required to operate the motors.</p> <p>Note: All approved devices are listed in the <i>PM 21</i> Catalog.</p>

1.2 I/O modules approved for SIMOTION

Approved I/O modules

Preferred peripherals for use with SIMOTION C:

- Centralized peripherals:
SIMATIC S7-300 I/O modules
- Distributed I/O systems for PROFIBUS and PROFINET:
 - **SIMATIC ET 200M** (distributed implementation of SIMATIC S7-300 I/O modules):
The modular I/O system for control cabinet installation and high channel density.
 - **SIMATIC ET 200S**:
The bit-modular I/O system for control cabinet installation including motor starters, safety technology and individual grouping of load groups.
 - **SIMATIC ET 200eco (only for PROFIBUS)**:
The compact, economical I/O system in IP 67 degree of protection for machine-level use without a control cabinet with flexible and fast ECOFAST or M12 connection system.
 - **SIMATIC ET 200pro**
New modular I/O system in IP65/66/67 degree of protection for machine-level use without a control cabinet; with new features such as small frame size, integrated PROFIsafe safety technology, PROFINET connection and hot swapping of modules.
- Other PROFIBUS DP I/O:
 - **ADI 4 (Analog Drive Interface)**
For the connection of drives with analog ± 10 V setpoint interface.
 - **IM174 (interface module for 4 axes)**
For the connection of drives with analog ± 10 V setpoint interface, external encoders or the connection of stepper drives with pulse-direction interface.

Note

Please note that not all modules of the above-mentioned I/O or I/O systems are approved for SIMOTION. Moreover, system-related functional differences can come into play when these I/O or I/O systems are used on SIMOTION vs. on SIMATIC. For example, special process-control functions (e.g. insertion and removal under voltage, etc.) are not supported by SIMOTION for the SIMATIC ET 200M distributed I/O system.

A detailed, regularly updated list of the I/O modules approved for use with SIMOTION, as well as notes on their use, can be found on the Internet at:

<http://support.automation.siemens.com/WWW/view/de/11886029>

In addition to the I/O modules approved for SIMOTION, all certified standard slaves can, in principle, be connected to SIMOTION if they support the following:

- Cyclic data traffic (DP-V0) and, possibly,
- Acyclic data traffic (DP-V1) or
- Isochronous data traffic (DP-V2)

These modules are integrated via the GSD file from the device manufacturer.

Note

Please note that in individual cases further boundary conditions must be fulfilled in order to integrate a standard slave into SIMOTION. Some modules need "driver blocks", e.g. in the form of function blocks, which make integration possible or much easier.

For modules approved for use with SIMOTION (e.g. S7-300 module FM 350-1, etc.), these driver blocks:

- Up to V3.2 SP1: SIMOTION Function Library
 - As of V4.0: SCOUT command library
-

1.3 The fundamentals of motion control

Position-controlled motion control for servo axes via the onboard drive interface (C230-2, C240)

These enable position-controlled motion control of up to four axes. The C230-2/C240 provides one analog output per axis for the speed setpoint and one encoder input per axis for the cyclic measurement of the actual position value.

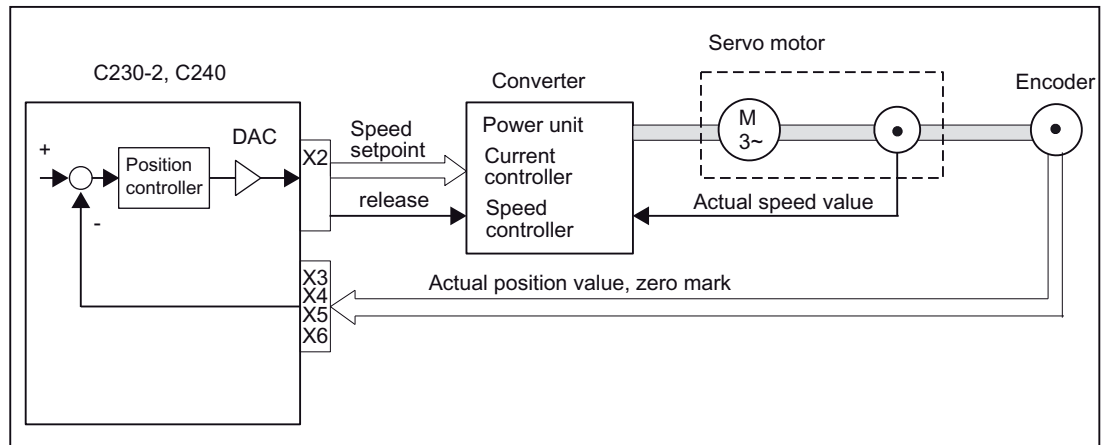

Figure 1-4 Servo system with converter, e.g. SIMODRIVE 611 universal, with built-in incremental encoder

Incremental encoder (C230-2, C240)

For position measurement, the encoders usually connected supply counting pulses according to their resolution for the distances traveled. These can be rotary encoders or linear scales.

Homing is necessary to determine the absolute position reference.

Absolute encoder (SSI, C230-2, C240)

Instead of conventional incremental encoders, which supply only a relative dimension for the distance traveled, absolute encoders with a serial interface can be connected. No homing operation need be performed for these encoders as they always supply the absolute position as an actual value.

A one-time adjustment is required for an axis with an absolute encoder when the machine is initially commissioned.

Encoder emulation (C230-2, C240)

Modern motor/converter systems often have a high-resolution motor measuring system (rotor position encoder) connected at the converter. Here the converter provides the position information via an interface that emulates an incremental encoder (e.g. incremental shaft encoder (WSG) interface with SIMODRIVE). A separate position measuring system is not required in this case.

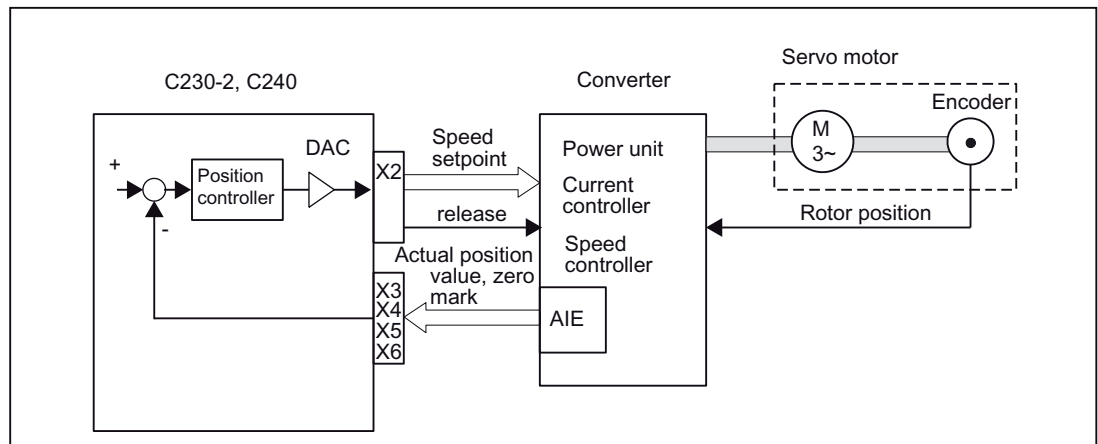

Figure 1-5 Servo system with converter, e.g. SIMODRIVE 611 universal, with incremental encoder

Position-controlled motion control for servo axes (PROFIBUS DP)

SIMOTION C enables position-controlled motion control of axes via PROFIBUS DP.

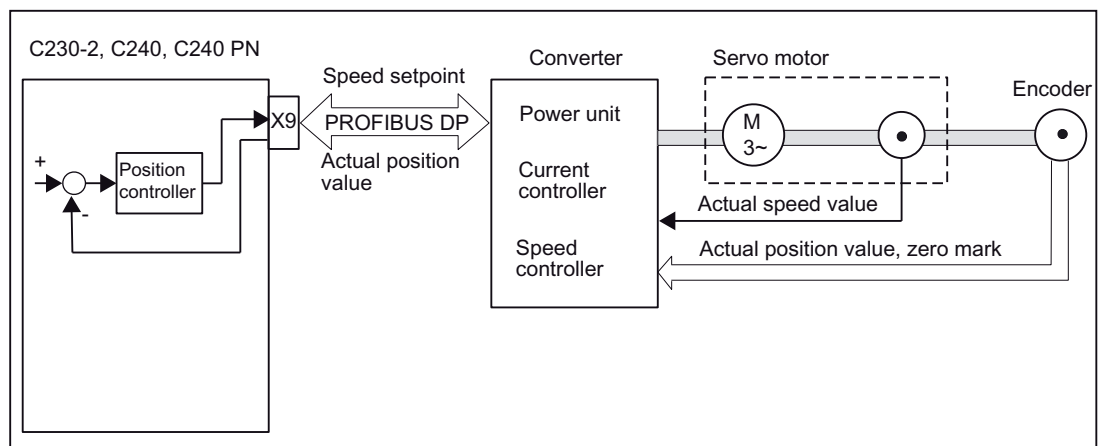

Figure 1-6 Servo system with converter, for example SIMODRIVE 611 Universal

Stepper motor control (C230-2, C240)

In addition to the analog setpoint outputs, the C230-2/C240 has pulse outputs for up to four stepper motor axes. The stepper motor is controlled by means of cycle clocks, the number of which determines the position and the frequency of which determines the rotational speed (velocity). The actual position value is not measured during controlled operation; the position controller takes the number of pulses output (position setpoint) as the actual value. With this type of control circuit, the motor cannot lose any steps in order to enable exact positioning.

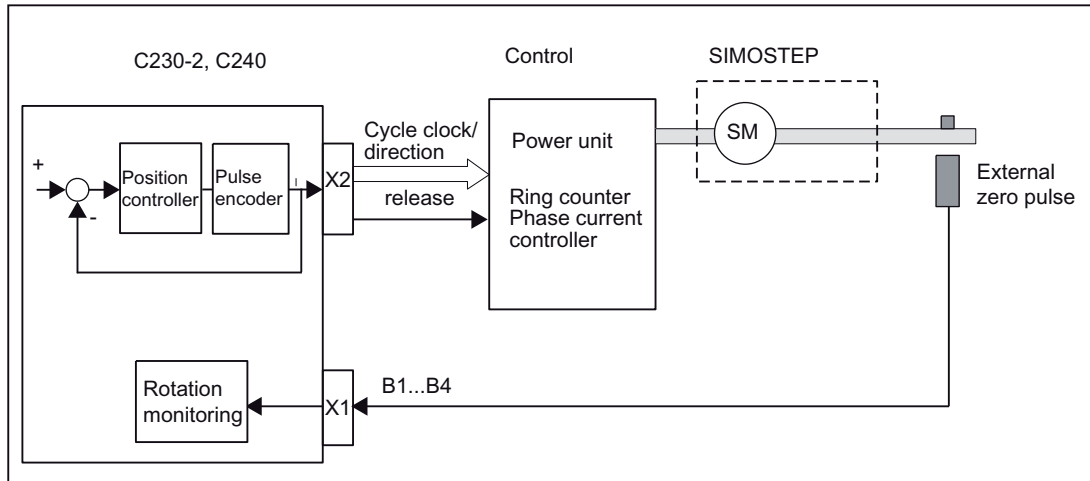

Figure 1-7 Controlled stepper motor system with control circuit

Position-controlled stepper motor control (C230-2, C240)

The C230-2, C240 also provide the option of using one encoder input per axis to operate stepper motors in closed-loop position control as a servo axis.

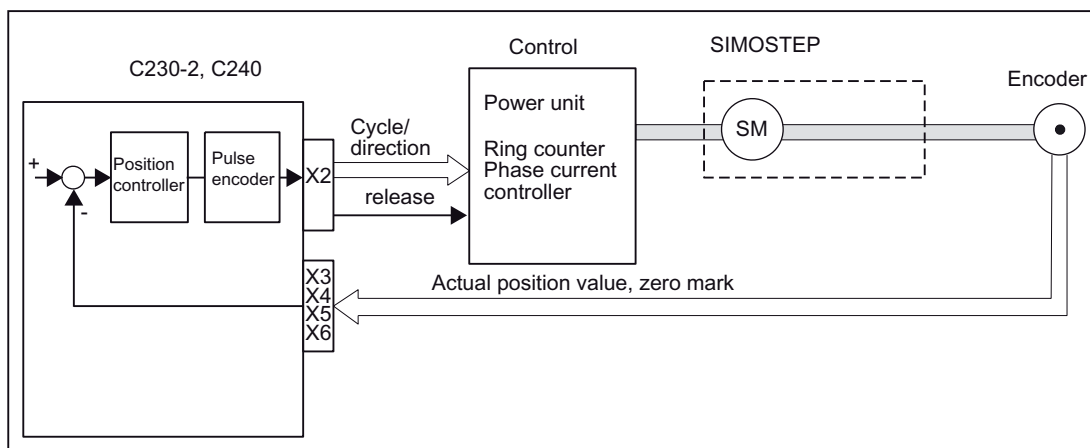

Figure 1-8 Position-controlled stepper motor system with control circuit

Position-controlled motion control for servo axes (C240 PN, PROFINET IO)

The C240 PN enables position-controlled motion control of axes via PROFINET IO.

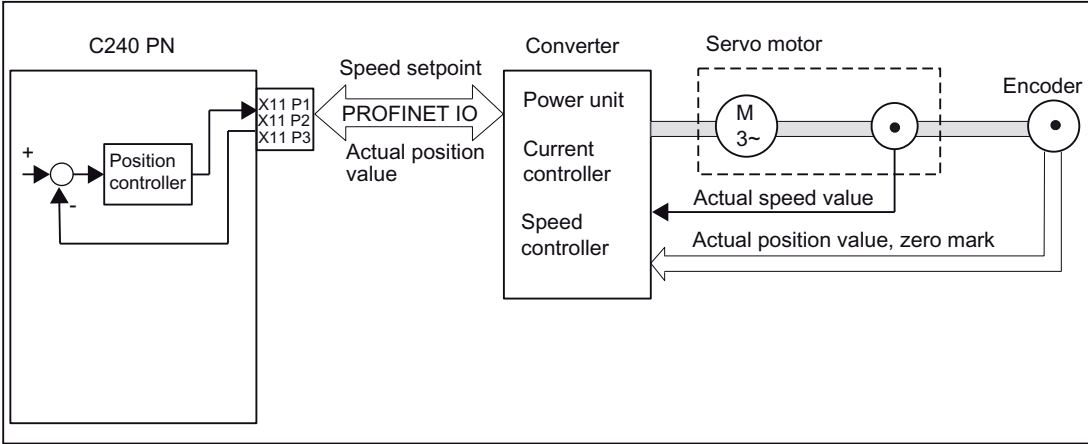

Figure 1-9 Servo system with converter, e.g. SINAMICS S120 with CBE20

1.4 Layout of the module

View of the C230-2

The following figure shows the C230-2 module, indicating the interfaces and components on the front panel (fault and status displays).

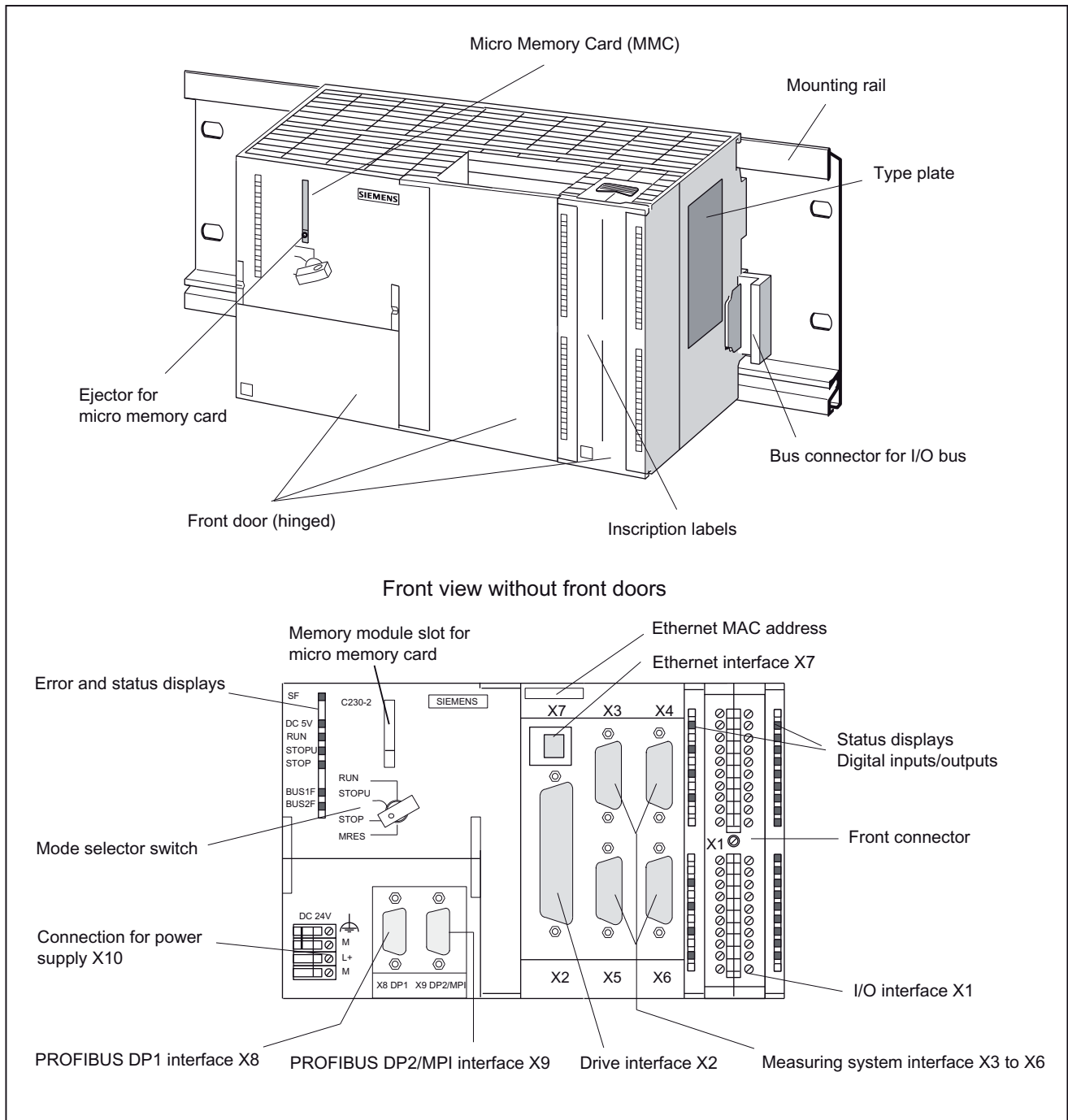

Figure 1-10 Position of the C230-2 interfaces and front panel elements

View of the C240

The following figure shows the C240 module, indicating the interfaces and components on the front panel (fault and status displays).

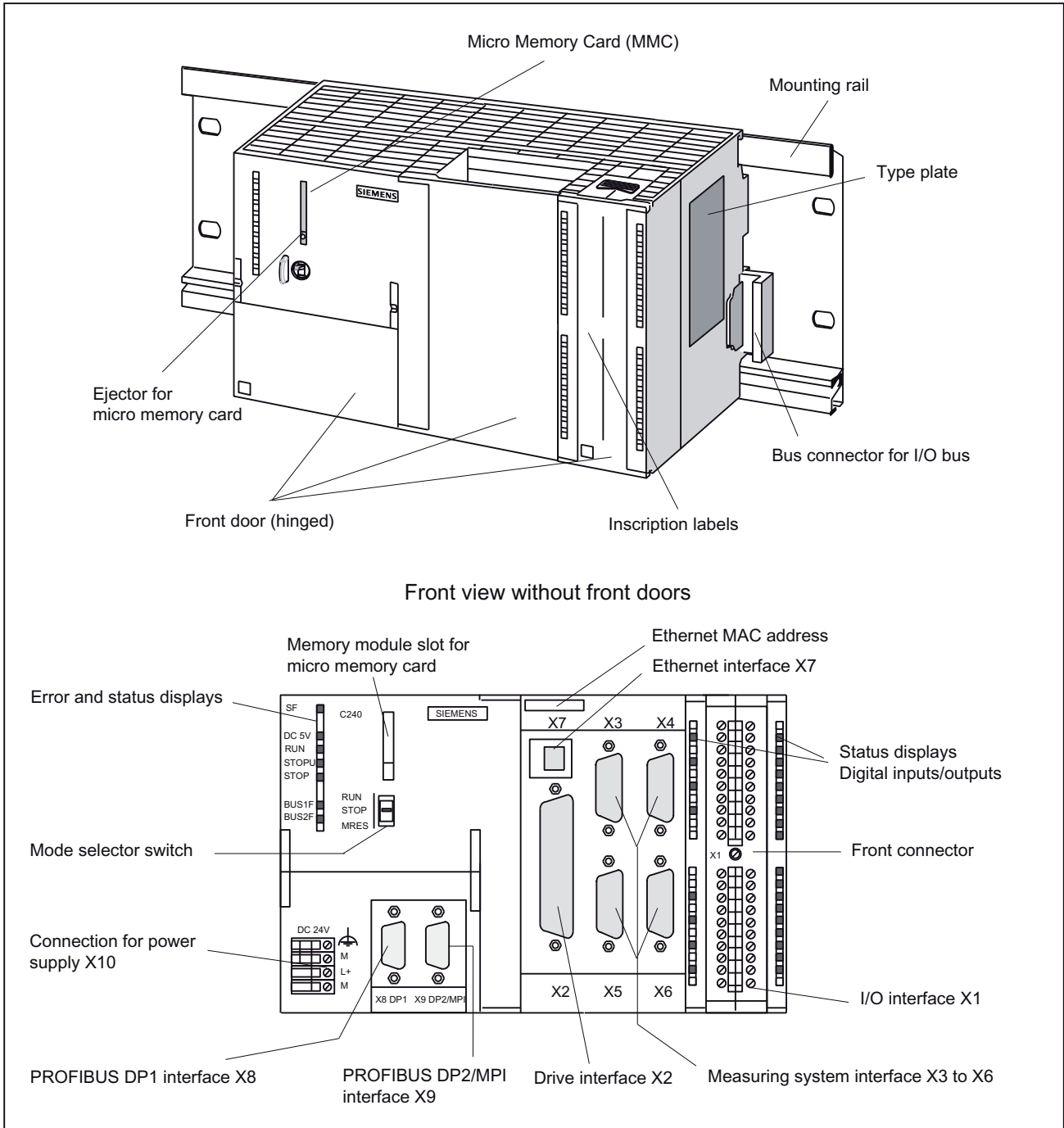

Figure 1-11 Position of the C240 interfaces and front panel elements

View of the C240 PN

The following figure shows the C240 PN module, indicating the interfaces and components on the front panel (fault and status displays).

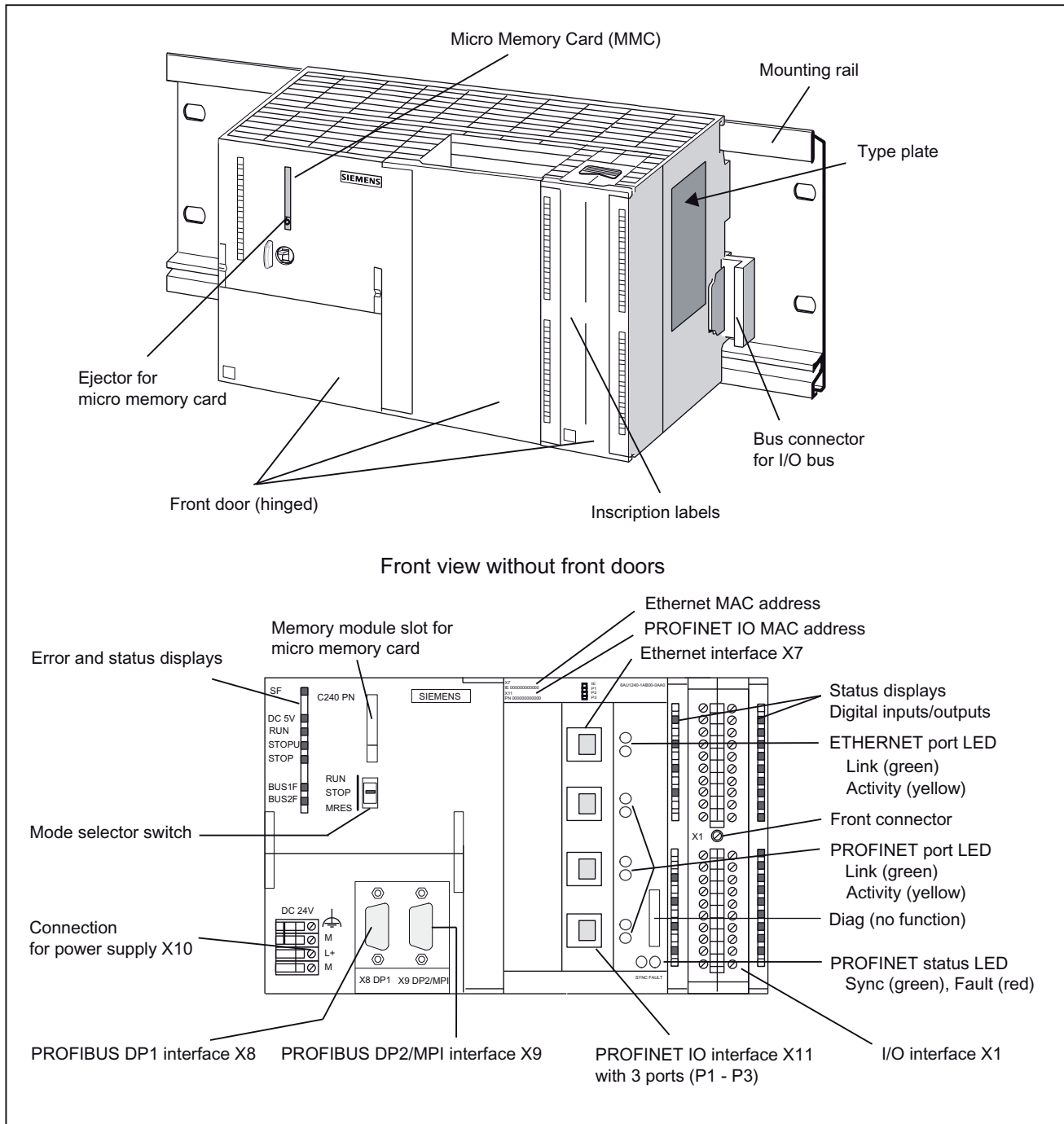

Figure 1-12 Position of the C240 PN interfaces and front panel elements

1.5 Nameplate

SIMOTION C type plates

The following figures explain all the information on the type plate.

Note

The contents of the individual type plate fields on the current module may differ from those described in this manual (e.g. updated product status, approvals and markings not yet issued, etc.).

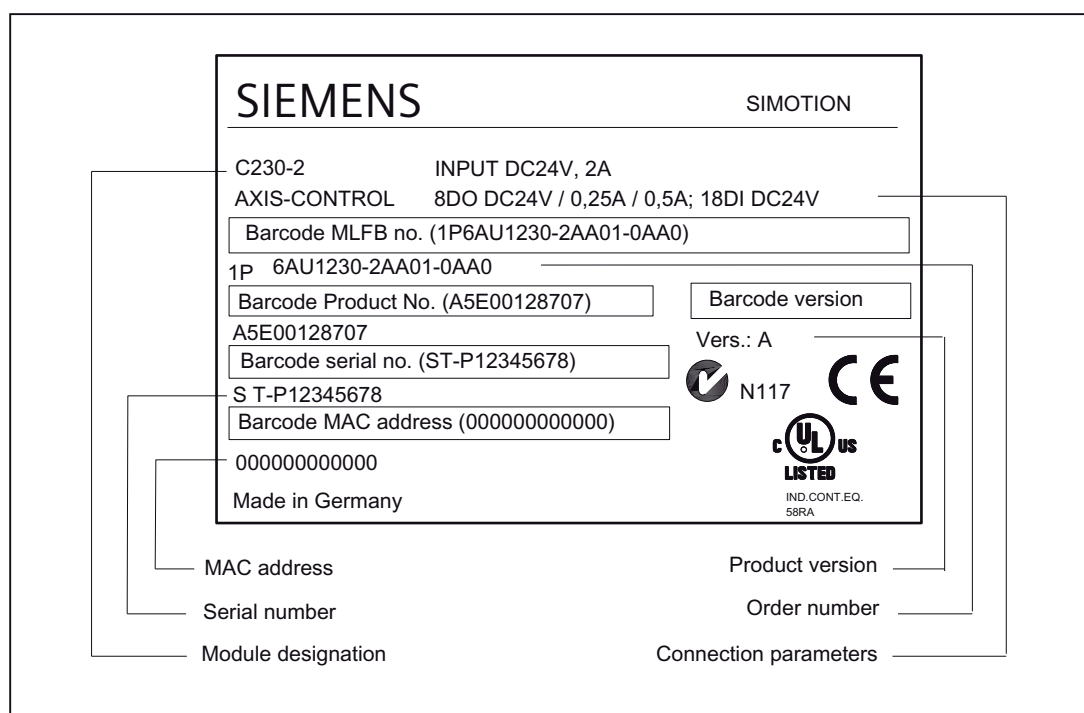

Figure 1-13 Type plate of the C230-2

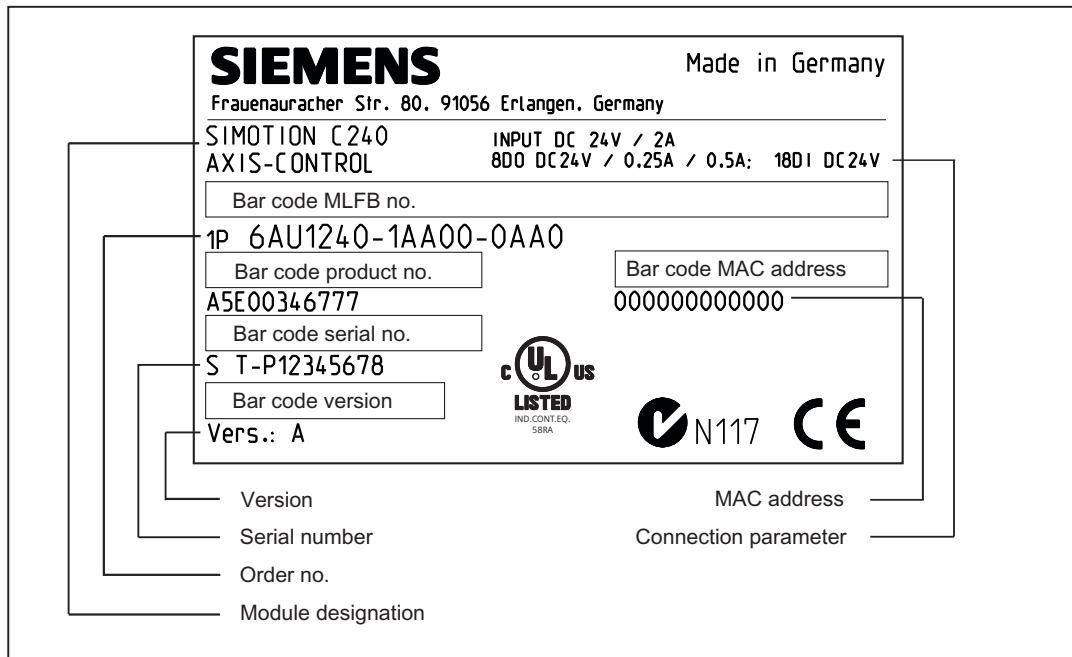

Figure 1-14 Type plate of the C240

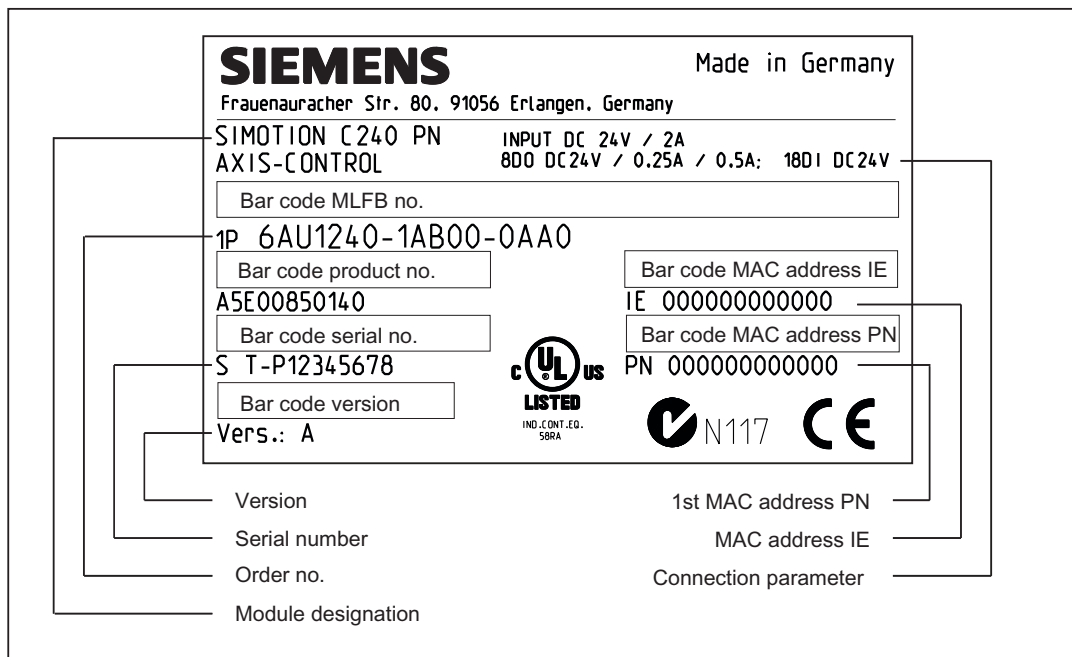

Figure 1-15 Type plate of the C240 PN

1.6 Versions of SIMOTION C

There are three different versions of the SIMOTION C: The previous C230-2, a more powerful C240 and a C240 PN with PROFINET interface. The C240 and C240 PN also have functional improvements, as compared to the C230-2.

Compared to the C230-2, the C240 and C240 PN have:

- A larger working memory
- A larger memory for retain data
- Higher performance

Instead of the onboard drive and measuring system interfaces, the C240 PN has a PROFINET interface with three ports (X11 P1, X11 P2, X11 P3).

The following table lists the differences between the individual motion controllers:

Table 1- 4 Differences between C230-2, C240 and C240 PN

	C230-2	C240	C240 PN
Order number of the module	6AU1 230-2AA01-0AA0	6AU1 240-1AA00-0AA0	6AU1 240-1AB00-0AA0
Order number of the Micro Memory Card (MMC)	6AU1 700-0AA02-0AA0	6AU1 720-1KA00-0AA0	
	Note: The MMC of the C240 and the C240 PN are identical.		
	Note: The MMC of the C240 / C240 PN cannot be operated in the C230-2 and vice-versa.		
Uses of the analog drive interface (X2)	<ul style="list-style-type: none"> • For analog drives • For stepper drives 	<ul style="list-style-type: none"> • For analog drives • For stepper drives • For standard outputs (analog/digital outputs) 	<ul style="list-style-type: none"> • Not available
Filter time for analog outputs	<ul style="list-style-type: none"> • With filter (C230-2-compatible) 	<ul style="list-style-type: none"> • With filter (C230-2-compatible) • Without filter 	<ul style="list-style-type: none"> • Not available
Repeatability when using the outputs as fast output cams (X1)	140 µs	70 µs	70 µs
Use of the inputs (X1: B1...B4)	<ul style="list-style-type: none"> • As digital inputs • For external zero mark signals 	<ul style="list-style-type: none"> • As digital inputs • For external zero mark signals • Measuring pulses for global measuring (in addition to inputs M1 and M2 for local measuring) 	<ul style="list-style-type: none"> • As digital inputs • Measuring pulses for global measuring
Use of measuring system interface (X3 to X6)	<ul style="list-style-type: none"> • Encoder connection 	<ul style="list-style-type: none"> • Encoder connection • Counter input 	<ul style="list-style-type: none"> • Not available

Description

1.6 Versions of SIMOTION C

	C230-2	C240	C240 PN
Mode selector (hardware)	Key-operated switch Switch positions: <ul style="list-style-type: none">• RUN• STOPU• STOP• MRES	Toggle switch Switch positions: <ul style="list-style-type: none">• RUN• STOP• MRES	Toggle switch Switch positions: <ul style="list-style-type: none">• RUN• STOP• MRES
PROFINET interface (X11)	Not available	Not available	3x PROFINET X11 P1, X11 P2, X11 P3

Note

In order to take the different versions into account, the product will be referred to in this manual as "SIMOTION C". Specific product designations will be used for information that applies only to one product version, e.g. for SIMOTION C230-2, C240 or C240 PN.

Operator control (hardware)

2.1 Control Elements

2.1.1 Mode selector

Certain operating modes can be selected using the mode selector.

Mode selector positions

The mode selector positions are explained in the order in which they are arranged on the SIMOTION C.

Table 2- 1 Modes and switch settings

Operating mode	Explanations
RUN	<p>SIMOTION C executes the user program (UP) and the associated system functions:</p> <ul style="list-style-type: none"> • Reading process image of inputs • Execution of the user programs assigned to the execution system • Writing process image of outputs <p>The technology packages are active in this state. They can execute commands from the user program.</p> <p>Note: With the C230-2, the key cannot be removed in this position.</p>
STOPU	<p>SIMOTION C does not execute a user program.</p> <ul style="list-style-type: none"> • The technology packages are active. Test and commissioning functions can be executed. The user program is not active. • The I/O modules (SMs) are in a safe state. <p>With the C230-2, the key can be removed in this position so that no unauthorized person can change the operating modes.</p> <p>Note: The toggle switch of the C240 / C240 PN does not have the "STOPU" switch setting. You can switch to "STOPU" mode only via the SIMOTION SCOUT engineering system. In SIMOTION SCOUT, you can switch from the hardware settings "STOP" and "RUN" to "STOPU" mode.</p>

Operating mode	Explanations
STOP	<p>SIMOTION C does not execute a user program.</p> <ul style="list-style-type: none"> • It is possible to load a complete user program. • All system services (communications, etc.) are active. • The I/O modules (SMs) are in a safe state. • The technology packages are inactive, i.e. all enables are deleted. No axis motions can be executed. <p>Note: With the C230-2, the key can be removed in this position so that no unauthorized person can change the operating modes.</p>
MRES (memory reset)	<p>Pushbutton position for memory reset on the SIMOTION C.</p> <p>A memory reset by means of a mode selector requires a specific sequence of operation, see chapter SIMOTION C memory reset (Page 154).</p>

2.1.2 Micro Memory Card (MMC)

SIMOTION C230-2 micro memory card

The following micro memory card is available:

Order no.: 6AU1 700-0AA02-0AA0

The micro memory card for SIMOTION C230-2 can be used to save the SIMOTION Kernel in order to run an update. See chapter SIMOTION kernel update (Page 159).

The SIMOTION Kernel should always be stored on the micro memory card.

As of SIMOTION V2.1, the SIMOTION Kernel is automatically copied to the micro memory card during power-up if it does not already contain one.

The micro memory card is also needed to save the technology packages and user data (programs, configuration data, parameterizations).

 CAUTION
<p>The micro memory card may only be inserted or removed when the control unit is disconnected from the power supply.</p>

Micro memory card for SIMOTION C240 / C240 PN

The following micro memory card is available:

Order no.: 6AU1 720-1KA00-0AA0

The micro memory card is **mandatory** for operating the SIMOTION C240 / C240 PN.

The micro memory card is supplied in a bootable format with the latest SIMOTION Kernel. It is **not** supplied with the SIMOTION C240 / C240 PN and must be ordered as a separate component.

Note: The SIMOTION C240 / C240 PN does not contain any firmware.

The micro memory card for the SIMOTION C240 / C240 PN can be used to save the SIMOTION Kernel.

The micro memory card is also needed to save the technology packages and user data (programs, configuration data, parameterizations).

 CAUTION
--

The micro memory card may only be inserted or removed when the control unit is disconnected from the power supply.
--

Memory module slot

The micro memory card is inserted in the memory module slot.

2.2 Display elements

LED displays

The following LED displays are on the front panel of the SIMOTION C. This table describes the LEDs and their function.

Table 2-2 Status and error displays

LED	Meaning
SF (red)	This LED indicates a fault on the SIMOTION C.
5 VDC (green)	This LED indicates that the power supply for the electronics is ready.
RUN (green) - SIMOTION C in RUN mode	This LED indicates that the user program is running.
STOPU (yellow) - SIMOTION C in STOP user program mode	This LED indicates that the technology packages (for example, synchronous operation and cam) are active. The user program is not active.
STOP (yellow) - SIMOTION C in STOP mode	This LED indicates that no user program is running. The technology packages are not active.
BUS1F (red) - Group fault	This LED indicates a fault on the SIMOTION C PROFIBUS DP1 interface (X8).
BUS2F (red) - Group fault	This LED indicates a fault on the SIMOTION C PROFIBUS DP2/MPI interface (X9).
Q0 to Q7 , I0 to I11 , B1 to B4, M1, M2 (green) - Digital inputs/digital outputs	These LEDs show the status of the digital inputs/outputs.

The following LED displays are arranged the front cover of the SIMOTION C240 PN. This table describes the LEDs and their function.

Table 2-3 Status and fault displays behind the front cover (C240 PN)

LED	Meaning
Ethernet link (X7) (green)	This LED indicates a physical connection of the Ethernet interface.
Ethernet activity (X7) (yellow)	This LED indicates a data transfer via the Ethernet interface.
PROFINET link (X11 Px) (green)	This LED indicates a physical connection of the PROFINET interface at port x.
PROFINET activity (X11 Px) (yellow)	This LED indicates a data transfer via the PROFINET interface at port x.
PROFINET fault (X11) (red)	This LED indicates a fault at the PROFINET interface.
PROFINET sync (X11) (green)	This LED indicates synchronization status of the PROFINET interface.

See also

Diagnosis using the LEDs (Page 165)

Interfaces

3.1 SIMOTION C interfaces

The interfaces and their meaning are described in following table.

Table 3- 1 Interfaces

Interfaces	Description
Bus connector	Rear-mounted connector for connecting to other S7 modules via the I/O bus
Drive interface (onboard) (C230-2, C240)	50-pin Sub-D connector X2 for the analog connection of analog and stepper drives (max. 4 axes)
Measuring system interface (onboard) (C230-2, C240)	15-pin Sub-D sockets X3 to X6 for connection of encoders (max. 4)
I/O interface	40-pin front connectors X1 for connecting the fast digital inputs/digital outputs including measuring inputs and external zero mark and for wiring the READY relay
Power supply connection	4-pin screw-type terminal connection X10 for connecting the 24 V load power supply
Memory module slot	Slot for micro memory card (MMC)
PROFIBUS DP1 interface	9-pin Sub-D socket X8 for connection to the PROFIBUS DP. This interface can be used for isochronous operation
PROFIBUS DP2/MPI interface	9-pin Sub-D socket X9 for connection to PROFIBUS DP (factory setting) or an MPI bus This interface can be used for isochronous operation.
Ethernet interface	8-pin RJ45 socket X7 for connection to an Industrial Ethernet
PROFINET interface with three ports (C240 PN)	3 x 8-pin RJ45 sockets X11 P1 , X11 P2 and X11 P3 for connecting to PROFINET subnets

3.2 Ethernet interface

Definition

Interface for connecting an Industrial Ethernet.

Industrial Ethernet is a communication network with a transmission rate of 10/100 Mbit/s.

The SIMOTION C provides the following functions via the Ethernet interface:

- Communication with STEP 7 and SIMOTION SCOUT
- Communication with distributed I/O (e.g. SIMATIC HMI)
- Communication between SIMOTION and SIMATIC NET OPC

The "SIMATIC NET SOFTNET S7 (S7 OPC server)" software must be installed on the PG/PC for this function.

Note:

SOFTNET-S7 is a superset of SOFTNET-PG, i.e. SOFTNET-S7 contains Protocol TCP/IP RFC 1006 as well.

For more information about the software packages, see *SIMOTION Motion Control System*, PM 21 Catalog. This documentation is supplied in electronic format with SIMOTION SCOUT.

Connectable devices

A PG/PC can be connected to the Ethernet interface via a Fast Ethernet network. The PG must be equipped with an Ethernet card and the corresponding software must be available.

Interface position

The following figures show the installation position and the designation of the interface on the C230-2, C240 and C240 PN modules.

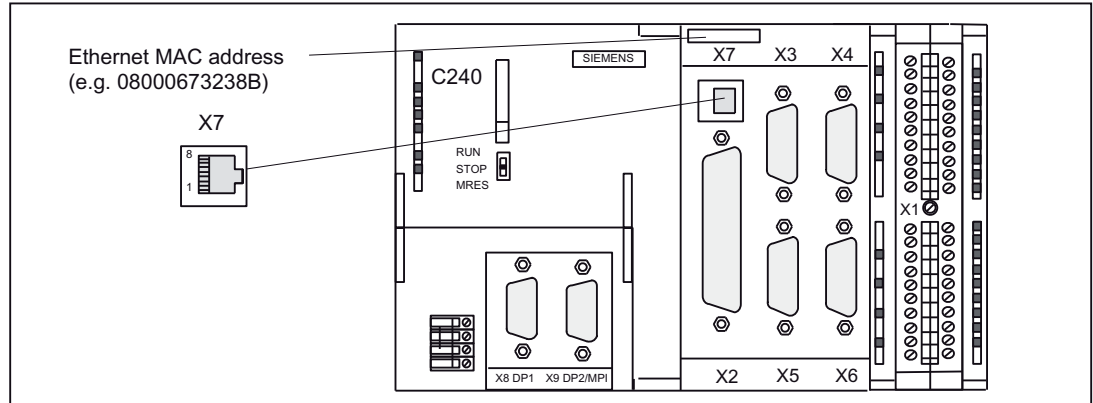

Figure 3-1 X7 interface position (C230-2, C240)

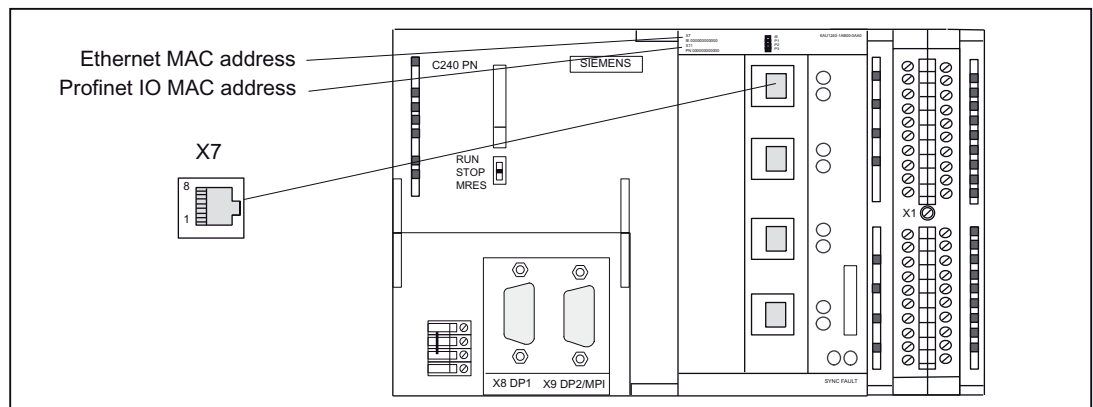

Figure 3-2 X7 interface position (C240 PN)

Interface assignment

Designation: **X7 (Ethernet)**

Type: 8-pin RJ45 socket

Table 3- 2 X7 interface assignment

Pin	Name	Type	Pin	Name	Type
1	TDP	O	5	Not assigned	
2	TDM	O	6	RDM	I
3	RDP	I	7	Not assigned	
4	Not assigned		8	Not assigned	

3.2 Ethernet interface

Signal names

RDP, RDM - Receive Data +/-
TDP, TDM - Transmit Data +/-

Signal type

I - signal input
O - signal output

Note

You will find additional information about Ethernet in the *SIMOTION SCOUT Communication System Manual*.

3.3 PROFINET interface (C240 PN)

Definition

A SIMOTION C240 PN provides an interface for connecting to PROFINET IO with three ports (X11 P1, X11 P2, X11 P3) with a transmission rate of 100 Mbit/s. The PROFINET interface supports the parallel operation of:

- IRT with the "high flexibility" and "high performance" options - isochronous real-time communication:
 - Equidistant transmission of input/output data between an IO controller and its IO devices with high stability for time-critical applications (e.g. motion control). The required bandwidth is in the bandwidth reserved for cyclic data. For "high flexibility", a fixed bandwidth of the transmission resources is reserved for the real-time communication. The "high flexibility" enables simple planning and expansion of the system. For "high performance", a fixed bandwidth of the transmission resources is also reserved for the real-time communication. The data traffic is further optimized and accelerated through an additional topology planning. The "high performance" option always requires a configuration of the topology.
 - With the aid of IRT "high performance", IO devices (I/O modules and drive units) that support IRT can be operated isochronously on PROFINET IO and data can be exchanged between the SIMOTION devices via the controller-controller data exchange broadcast.
- RT - real-time communication: Transmission of input/output data between an IO controller and its IO devices in prioritized Ethernet message frames, but not isochronously. The required bandwidth is in the bandwidth of PROFINET IO reserved for cyclic data.
- Standard Ethernet communication such as TCP/IP, UDP, HTTP, FTP, etc. as well as communication with STEP 7 / SIMOTION SCOUT and communication with SIMATIC NET OPC:
The required bandwidth is in the free bandwidth of PROFINET IO.

A SIMOTION C240 PN can be used as IO controller or I device. PROFINET IO differentiates between an IO controller and the IO devices assigned to it. IO controller and IO devices form a PROFINET IO system, comparable to a master-slave system on PROFIBUS DP.

Connectable devices

The following devices can be connected to the PROFINET interface:

- PG/PC programming device
- SIMATIC HMI devices
- SIMATIC S7 controllers with PROFINET interface
- Distributed I/O (e.g. SIMATIC ET 200M) with PROFINET interface
- Drive units with PROFINET interface
- SIMOTION devices with PROFINET interface according to PROFIdrive profiles / IEC61800-7
- Teleservice adapter
- Gateways

Note

All released modules and devices are listed in the PM 21 Catalog and in chapter I/O modules approved for SIMOTION (Page 18). This documentation is supplied in electronic format with SIMOTION SCOUT. Take note of the documentation on the individual modules or devices!

Interface position

The following figure shows the mounting position and the designation of the PROFINET IO interface on the module.

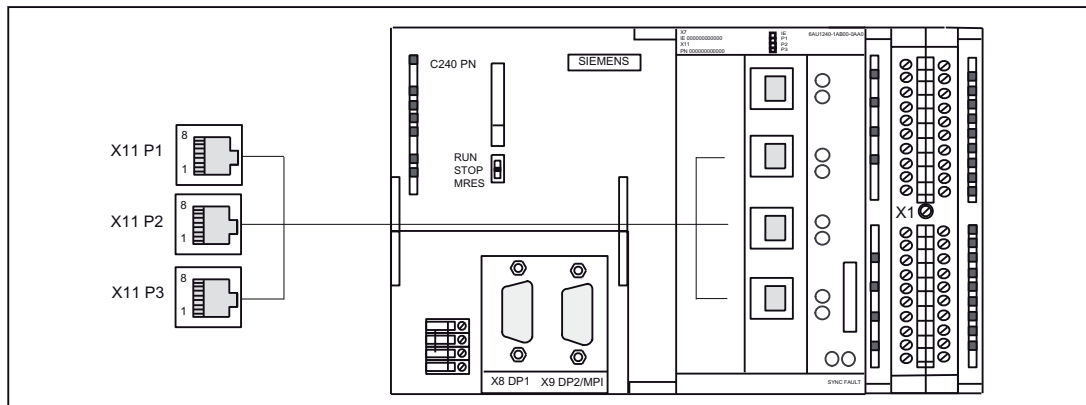

Figure 3-3 X11 interface position (C240 PN), three ports P1, P2, P3

The following LED displays are arranged behind the front cover of the SIMOTION C240 PN. For a description of the LED displays, see section Display elements (Page 34).

Interface assignment

Designation: X11 (PROFINET), three ports P1, P2, P3

Type: 8-pin RJ45 socket

Table 3- 3 X11 interface assignment (ports P1, P2, P3)

Pin	Name	Type	Pin	Name	Type
1	TDP	O	5	Not assigned	
2	TDM	O	6	RDM	I
3	RDP	I	7	Not assigned	
4	Not assigned		8	Not assigned	

Signal names

RDP, RDM - Receive Data +/-

TDP, TDM - Transmit Data +/-

Signal type

I - signal input

O - signal output

Note

You will find additional information about PROFINET in the *SIMOTION SCOUT Communication System Manual*.

3.4 PROFIBUS DP interfaces

PROFIBUS DP interfaces (X8, X9)

The SIMOTION C provides two interfaces for connection to the PROFIBUS DP. Baud rates up to 12 Mbits/s are possible. Both interfaces can be operated isochronously.

If both interfaces (X8, X9) are to be operated isochronously, then they must both be configured with the same DP cycle clock.

Alternatively, the X9 interface can be used as an MPI interface with a transmission rate up to 12 Mbits/s.

Connectable devices

The following devices can be connected to the PROFIBUS DP interfaces:

- PG/PC
- SIMATIC HMI devices
- SIMATIC S7 controllers with PROFIBUS DP interface
- Distributed I/O (e.g. SIMATIC ET 200M)

The digital inputs/digital outputs are updated in the position control cycle clock.

- SIMOTION controller
- Teleservice adapter
- Drive units with PROFIBUS DP interface (e.g. SIMODRIVE 611 universal) according to PROFIdrive profiles / IEC61800-7.

Note

A teleservice adapter can only be connected to **one** of the two interfaces.

All released modules and devices are listed in the *PM 21* Catalog and in chapter I/O modules approved for SIMOTION (Page 18). This document is supplied in electronic format with SIMOTION SCOUT.

Take note of the documentation on the individual modules or devices!

Interface positions

The following figure shows the mounting position and the designation of the interfaces on the module.

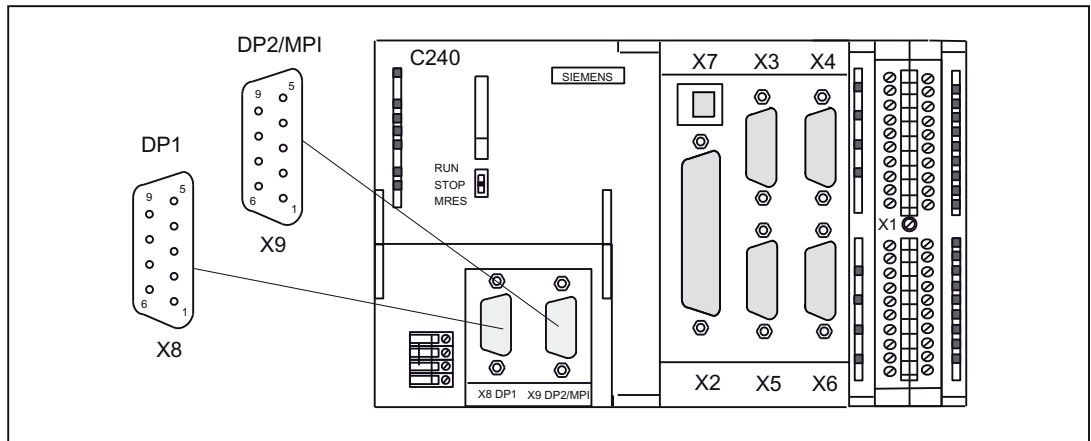

Figure 3-4 Position of connectors X8, X9

Interface assignments

Designation: **X8, X9** DP1, DP2/MPI Type: 9-pin Sub-D socket connector

Table 3- 4 X8, X9 interface assignments

Pin	Name	Type	Pin	Name	Type
1	Not assigned		6	P5	VO
2	M24	VO	7	P24	VO
3	B	I/O	8	A	I/O
4	RTS	O	9	Not assigned	
5	M5	VO			

Signal names

Table 3- 5 Signal names

Signal name	Meaning
A, B	Data input/output (RS485)
RTS	Transmission request
P5	5 V power supply 60 mA, short-circuit-proof
M5	5 V reference potential
P24	24 V supply 150 mA, short-circuit-proof, not isolated
M24	24 V reference potential

Signal type

O - signal output
I/O - signal input/output
VO - voltage output

3.5 Onboard drive interface (C230-2, C240)

Connector to drive unit

Drive units with an analog interface (± 10 V) or stepper motor power units with at least one clock pulse input and direction input can be connected to the 50-pin Sub-D socket X2. Any hybrid configuration can be used for up to four drives.

In addition, the C230-2 and C240 provide one enable signal per axis.

With the C240, this interface (X2) can also be used for standard outputs:

- 4 analog outputs
- 4 digital outputs

Position of the connector

The following figure shows the installation position and the designation of the connector on the module.

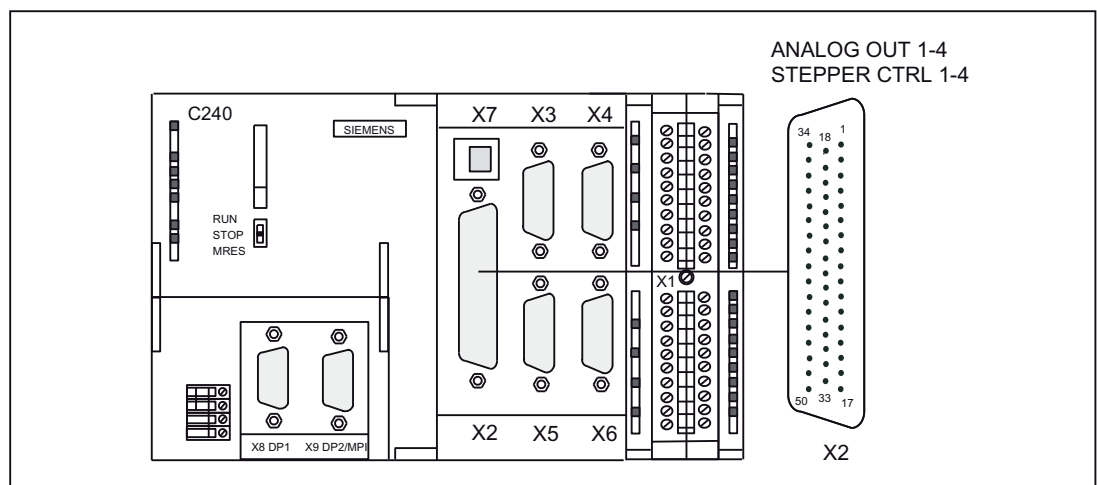

Figure 3-5 Position of the X2 connector

3.5 Onboard drive interface (C230-2, C240)

Connector pin assignment

Onboard drive interface (servo interface, 4 axes)

Connector designation: X2 ANALOG OUT 1-4/STEPPER CTRL 1-4

Connector type: 50-pin Sub-D plug connector

Table 3- 6 X2 connector pin assignment

Pin	Name	Type	Pin	Name	Type	Pin	Name	Type
1	SETP1	VO	18	ENABLE1	O	34	REFPOT1	VO
2	REFPOT2	VO	19	ENABLE1_N	O	35	SETP2	VO
3	SETP3	VO	20	ENABLE2	O	36	REFPOT3	VO
4	REFPOT4	VO	21	ENABLE2_N	O	37	SETP4	VO
5	PULSE1	O	22	GND	O	38	PULSE1_N	O
6	DIR1	O	23	GND	O	39	DIR1_N	O
7	PULSE2_N	O	24	GND	O	40	PULSE2	O
8	DIR2_N	O	25	GND	O	41	DIR2	O
9	PULSE3	O	26	ENABLE3	O	42	PULSE3_N	O
10	DIR3	O	27	ENABLE3_N	O	43	DIR3_N	O
11	PULSE4_N	O	28	ENABLE4	O	44	PULSE4	O
12	DIR4_N	O	29	ENABLE4_N	O	45	DIR4	O
13	Not assigned		30	Not assigned		46	Not assigned	
14	CTREN1.1	C	31	Not assigned		47	CTREN1.2	C
15	CTREN2.1	C	32	Not assigned		48	CTREN2.2	C
16	CTREN3.1	C	33	Not assigned		49	CTREN3.2	C
17	CTREN4.1	C				50	CTREN4.2	C

Signal names

Table 3- 7 Signal names for drives with analog interface

Signal name	Meaning
SETP[1 to 4]	Setpoint
REFPOT[1 to 4]	Reference potential for setpoint (analog ground)
CTREN[1.1 to 4.1], CTREN[1.2 to 4.2]	Controller-enable contact

Table 3- 8 Signal names for stepper drives:

Signal name	Meaning
PULS[1 to 4], PULS[1 to 4]_N	Clock pulse is inverted and not inverted
DIR[1 to 4], DIR[1 to 4]_N	Clock pulse inverted and non-inverted
ENABLE[1 to 4], ENABLE[1 to 4]_N	Controller enable inverted and non-inverted
GND	Signal ground

Signal type

- O - signal output
- VO - voltage output
- K - switching contact

Drives with analog interface

Signals:

One voltage signal and one enable signal are provided per axis.

- **Setpoint (SETP)**

Analog voltage signal in the ± 10 V range for the output of a speed setpoint.

- **Reference potential (REFPOT)**

Reference potential (analog ground) for the setpoint signal, connected internally to logic ground.

- **Controller enable (CTREN)**

Contact assembly mated set (NO contact), used for axis-specific enabling of the drive, e.g. a SIMODRIVE drive unit. The RF signal to the drive is set as soon as the controller enable is signaled by the user program.

Note: When used as a digital output, the contact must be supplied with voltage.

 WARNING
--

Brief voltage peaks may occur at the analog outputs when the supply voltage is switched on or off.

For this reason, it is important to make sure that the enable signals are wired correctly and that the necessary safety regulations are met.

Stepper drives

Signals:

One clock pulse signal, direction signal, and enable signal is provided as a true and negated signal.

- **Setpoint (PULS)**

The clock pulses control the motor. The motor performs one step for each rising pulse edge.

Thus, the number of pulses output determines the angle of rotation, i.e. the distance to be traversed.

The pulse frequency determines the rotational speed, i.e. the traversing speed.

 CAUTION
If your drive unit responds to falling pulse edges, you must replace the true pulse signal with the negated pulse signal when performing the wiring; failure to do so can cause deviations to occur between the position calculated by the controller and the actual position.

- **Direction signal (DIR)**

The output signal level determines the direction of rotation of the motor.

Signal ON: "Rotation to the left"

Signal OFF: "Rotation to the right"

Note

If the direction of rotation of the motor is different, you can change the direction of rotation by means of the "Reversal of traversing direction" configuration data element. Refer to the technical documentation of your drive unit for the correct assignment of the signal levels to the direction of rotation.

- **Enable signal (ENABLE)**

This signal is activated when the axis enable is set in RUN mode by the user program.

Signal ON: Power control circuit enabled

Signal OFF: Depending on the power unit, one or more of the following responses can occur:

- Disable pulse input
- Deenergize motor
- Reset ring counter
- Delete error messages

Note

The ENABLE signal is output at the same time with controller enable contact RF. Alternatively, you can also use the relay contacts.

Signal parameters

All signals for stepper drives are output by means of differential signal line drivers in accordance with the RS422 standard. For optimal reliability, the power unit should have differential signal receivers or optical coupler inputs to enable symmetrical signal transmission. An asymmetrical transmission is also possible, however, the maximum cable length in this case is limited to 10 m.

Note

Because of the wide range of non-standardized input circuits of the drive units during asymmetrical transmission, no responsibility can be taken for this function. In particular, cable lengths and the limit frequency depend on the properties of the input circuit and the cable being used. In addition, the GND reference potential should be isolated to prevent electrical interference.

All outputs are electronically protected against short-circuit and thermal overload.

The following figure shows different possibilities for protective signal circuits.

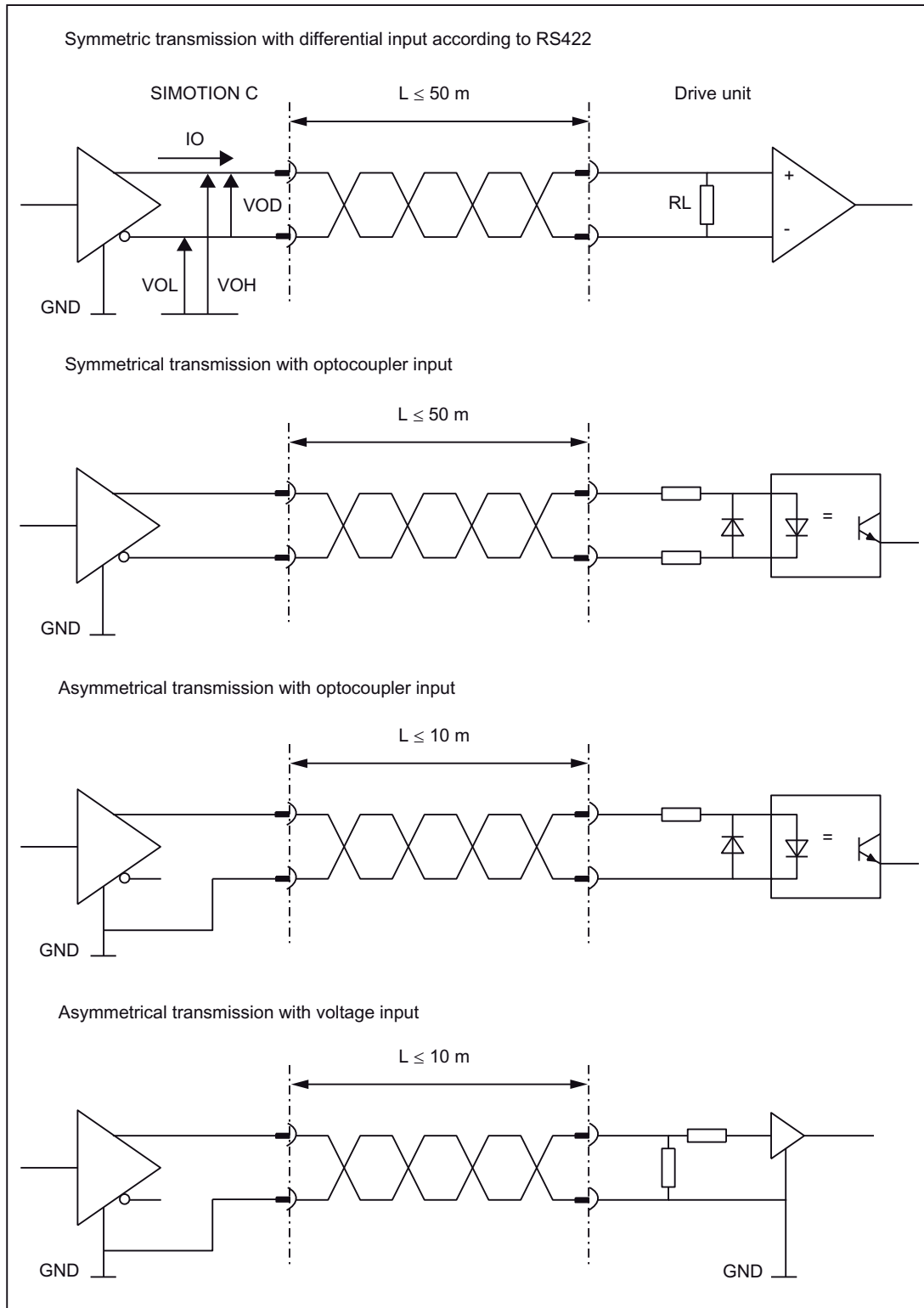

Figure 3-6 Possible protective signal circuits for the stepper motor interface

Use as standard outputs (analog/digital output) for C240

The setpoint signals (connector X2, SETP1 to 4) can also be used on the C240 as four analog outputs. The analog output (X2) has a filter that can be switched off.

The default setting is "with filter (C230-2-compatible)". This setting is active regardless of whether the four outputs are used (actuating signal for axis or analog output). Output values are interpolated linearly via the servo cycle clock.

Procedure:

1. Select the **C240** in the rack.
2. Select the menu command **Edit > Object Properties** to open the **Properties C240 - (R0/S2)** dialog.
3. You can set the filter time in the **Onboard I/O** tab.

The controller enable contacts (connector X2, CTREN1 to 4) can also be used on the C240 as four digital outputs. These digital outputs are isolated relay contacts (NO).

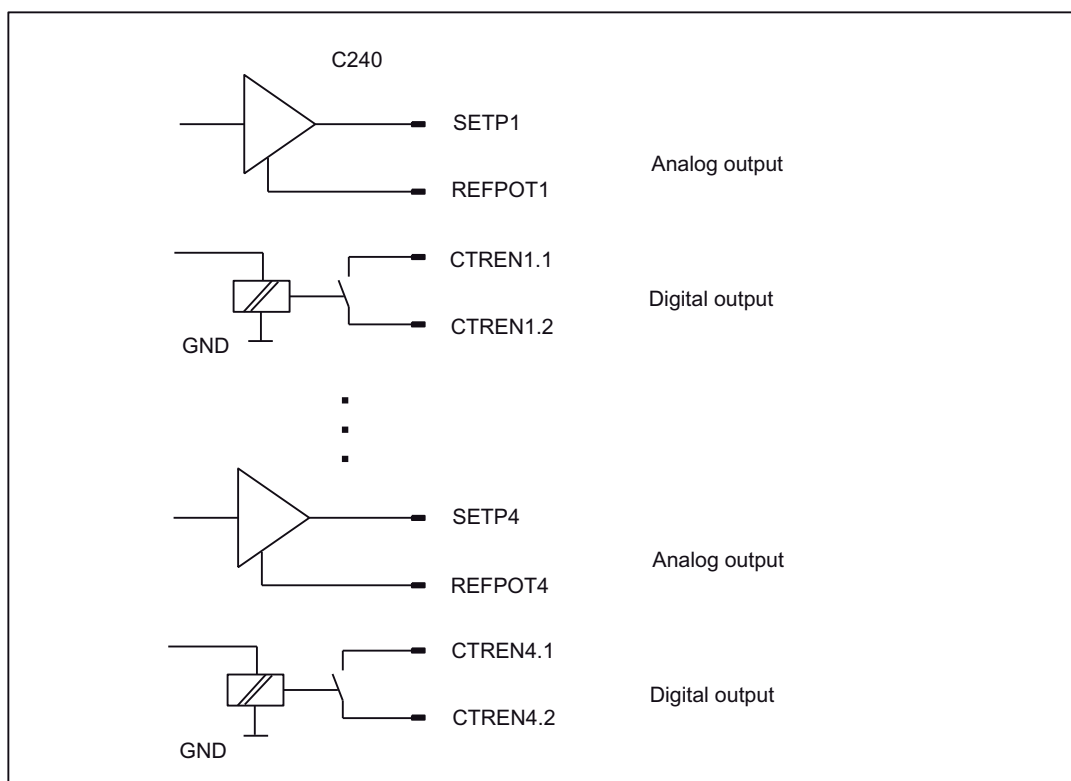

Figure 3-7 Use as standard outputs

See also

Overview (Page 63)

3.6 Onboard measuring system interface (C230-2, C240)

Connectors to the encoder

A 15-pin Sub-D socket for the connection of incremental or absolute encoders (SSI) is provided for each axis.

With the C240, this interface (X3 to X6) can also be used as a counter input.

Position of connectors

This figure shows the mounting position and the designation of the connector on the module.

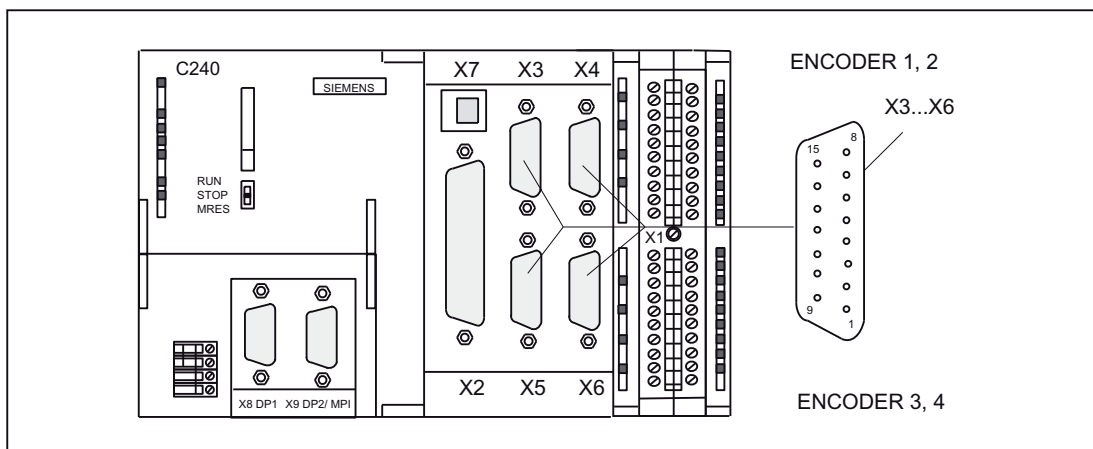

Figure 3-8 Position of connectors X3 to X6

Connector pin assignment

Designation:

X3, X4, X5, X6 - ENCODER 1 to 4

Assignment of ENCODER - axis channel:

X3 - axis channel 1

X4 - axis channel 2

X5 - axis channel 3

X6 - axis channel 4

Type: 15-pin Sub-D socket connector

Table 3- 9 Assignment of connectors X3 to X6

Pin	Encoder		Type	Pin	Encoder		Type
	Incremental	Absolute			Incremental	Absolute	
1	Not assigned			9	MEXT		VO
2		CLS	O	10	Z		I
3		CLS_N	O	11	Z_N		I
4	P5EXT		VO	12	B_N		I
5	P24EXT		VO	13	B		I
6	P5EXT		VO	14	A_N	DATA_N	I
7	MEXT		VO	15	A	DATA	I
8	Not assigned						

Signal names

Table 3- 10 Measuring system interface signal names

Signal name	Meaning
A, A_N	Track A non-inverted and inverted (incremental encoder)
B, B_N	Track B non-inverted and inverted (incremental encoder)
Z, Z_N	Zero mark non-inverted and inverted (incremental encoder)
CLS, CLS_N	SSI clock shift non-inverted and inverted (absolute encoder)
DATA, DATA_N	SSI data non-inverted and inverted (absolute encoder)
P5EXT	+5 V supply
P24EXT	+24 V supply
MEXT	Supply ground

Signal type

VO - voltage output (supply)

O - output (5 V signal)

I - input (5 V signal)

Types of encoder that can be connected

Both rotary (shaft encoders, angle measurement systems) and linear (linear encoder, linear measurement systems) measuring systems can be used. These can be built on the machine/system (incremental encoder) or integrated in the motor (rotor shaft angle encoder).

The following table gives you an overview of the encoders that can be connected and what you should take into account here.

Table 3- 11 Encoders which can be connected

Encoder	Connection to X3 to X6 of the C230-2/C240
<p>Rotary encoders</p> <ul style="list-style-type: none"> • Incremental encoders with 5 V encoder power supply and TTL/RS422 interface • Incremental encoders with 24 V encoder power supply and TTL/RS422 interface • Absolute encoders (single/multi-turn) with 24 V encoder power supply and SSI interface • Shaft position encoders with 5 V encoder power supply and TTL/RS422 interface • Rotor position encoder with SINE signals • Resolver 	<ul style="list-style-type: none"> • Direct • Direct • Direct • Direct • Via SIMODRIVE drive control using incremental shaft encoder (WSG) interface • Via SIMODRIVE resolver control using incremental shaft encoder (WSG) interface
<p>Linear encoders</p> <ul style="list-style-type: none"> • Length measurement systems with 5 V encoder power supply and TTL/RS422 interface • Linear encoders with SINUSOIDAL signals 	<ul style="list-style-type: none"> • Direct • Via EXE (external pulse shaper electronics)

Note

If you operate drives via the PROFIBUS DP, you do not need to connect any encoders to this interface. The encoders are connected directly to the drive.

Encoder emulation (incremental shaft encoder (WSG) interface)

If the drive unit is equipped with encoder emulation, this can be connected instead of an encoder. The drive control analyzes the information from a rotor shaft angle encoder and provides information on the actual position to this interface by emulating the signals of an incremental encoder.

Note

Please note the drive manufacturer's wiring specifications. As the encoder interface of the C230-2, C240 is non-isolated, it may be necessary to take special measures for EMC on a case-by-case basis.

Encoder properties

Incremental encoder

Table 3- 12 Incremental encoder properties

Property	Condition
Transmission procedure:	Differential transmission using 5 V rectangular signals (as in RS422 standard)
Output signals:	Track A as non-inverted and inverted signal (U_{a1} , $\overline{U_{a1}}$)
	Track B as non-inverted and inverted signal (U_{a2} , $\overline{U_{a2}}$)
	Zero signal Z as non-inverted and inverted signal (U_{a0} , $\overline{U_{a0}}$)
Max. output frequency:	1 MHz
Phase shift of Track A to Track B:	$90^\circ \pm 30^\circ$
Current consumption:	max. 300 mA

Signal forms of incremental encoders

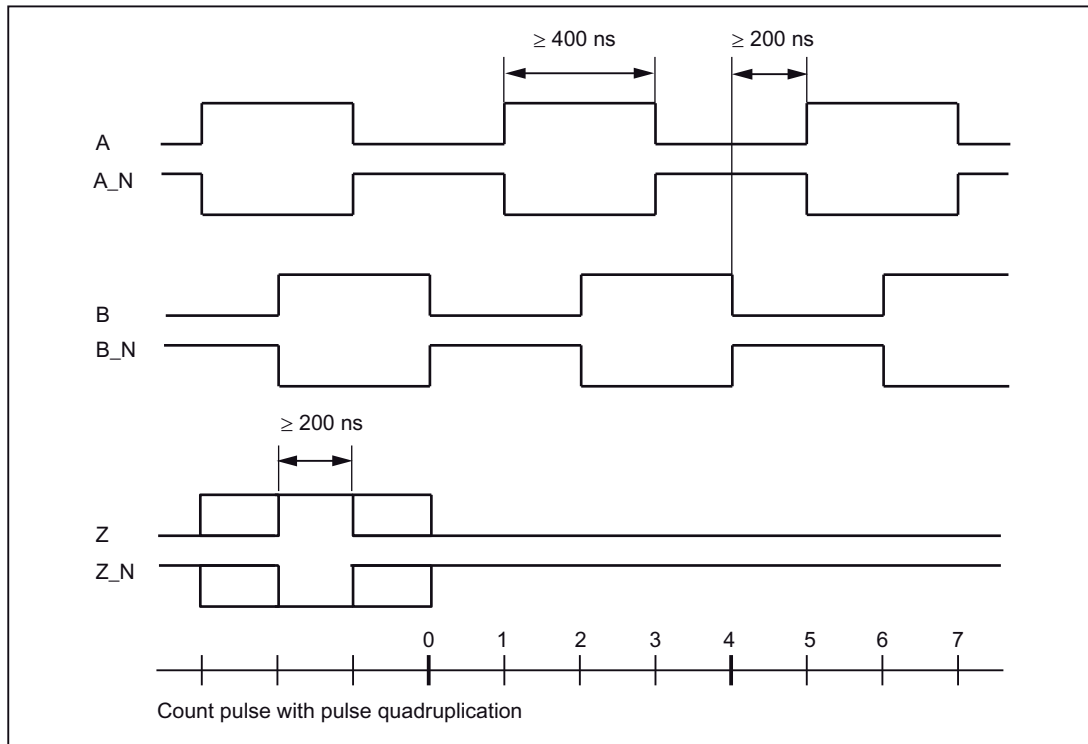

Figure 3-9 Signal forms of incremental encoders

Note

If you want to connect incremental encoders without zero signals, then you must connect the corresponding pins in the connector with the encoder power supply:

Pin 10 with Pin 7 or 9 (MEXT)

Pin 11 with Pin 4 or 6 (P5EXT)

Encoder connection via EXE

Encoders or EXEs (external pulse shaper electronics - for the connection of linear position encoders) that can be connected directly must fulfill the above conditions:

Absolute encoder (SSI)

Table 3- 13 Properties of absolute encoders (SSI)

Property	Features
Transmission procedure:	Synchronous serial interface (SSI) with 5 V differential signal transmission (as in RS422 standard)
Output signal:	Data as non-inverted and inverted signal
Input signal:	Clock shift as non-inverted and inverted signal
Format:	Single/multi-turn
Resolution:	max. 25 bits
Max. transmission rate:	1.5 Mbits/s
Current consumption:	max. 300 mA

Configuration of absolute value encoders (SSI)

The configuration data of the TO axis and/or TO external encoder must perfectly match the parameters of the SSI encoder. Encoders which transmit a greater number of data bits than are to be read in the set SIMOTION C message length cannot be connected. The configuration data can be set within the range of the maximum values specified in the following message profiles (fir tree or right-justified).

Fir tree profile

The encoder always transmits the number of revolutions with the first 12 cycles. The configured encoder pulses per revolution is monitored by the encoder driver for the configured message length less these 12 cycles. The maximum configurable data width is monitored for the number of bit digits needed for representation of the configured encoder pulses per revolution in the telegram plus these 12 cycles.

Configuration data:

Message length: 13/21/25 cycles can be selected (asymmetric fir tree profile)

Encoder pulses per revolution: $\leq 2^{(\text{message length} - 12)}$

Data width: $\leq 12 + (\log \text{ encoder pulses per revolution} / \log 2)$

Note: The number of bit digits needed for representation of the encoder pulses per revolution is calculated using $(\log \text{ encoder pulses per revolution} / \log 2)$.

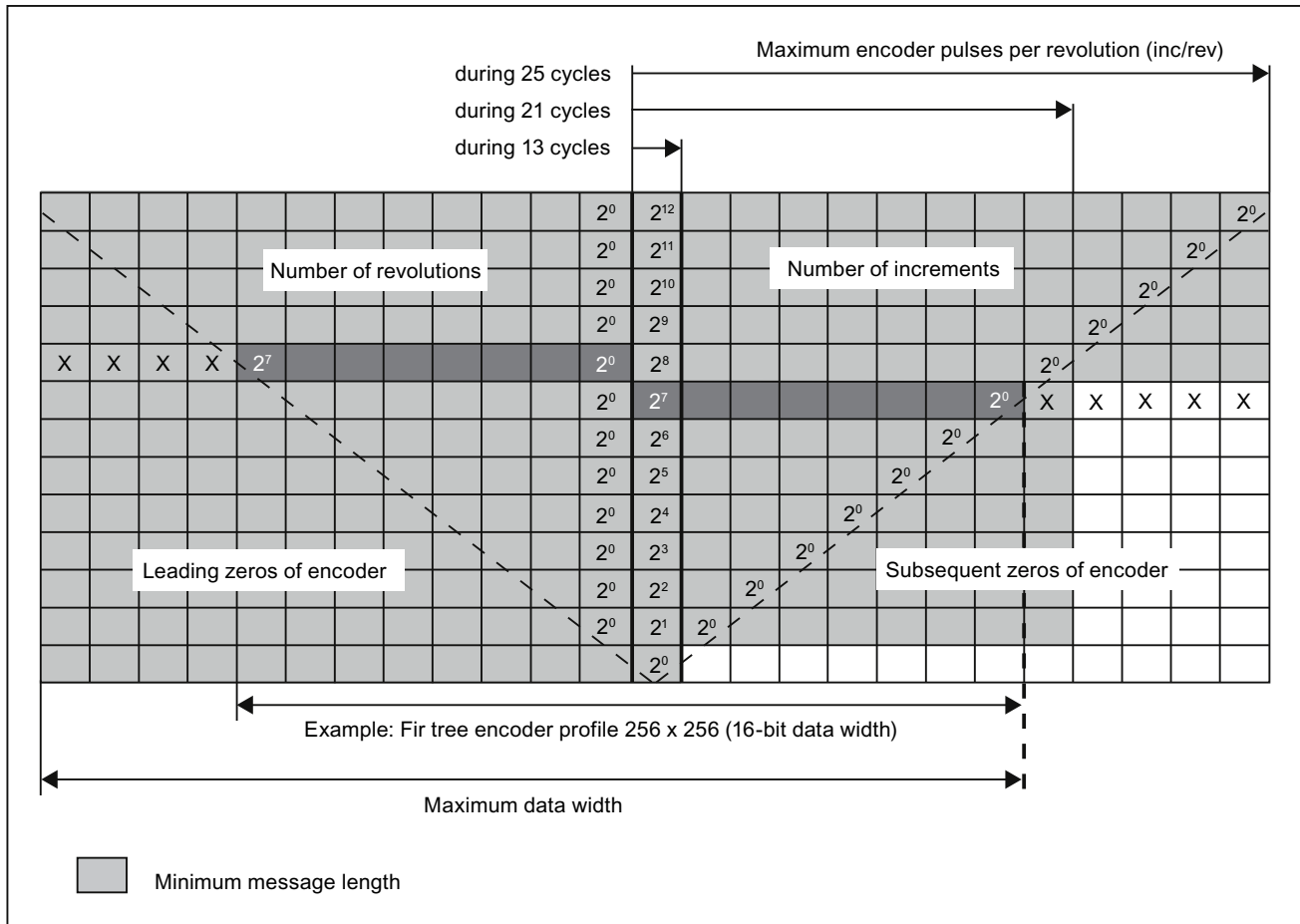

Figure 3-10 Fir tree profile

Note

Please note the following:

- Bit 2^0 of the number of revolutions is fixed on the 12th cycle, followed on the 13th cycle by the most significant bit of the number of increments/revolution.
- The leading and subsequent data bits transmitted by the encoder (or zeros) are not evaluated by SIMOTION C.
- The encoder used in the example should be configured as follows:
 - Encoder pulses per revolution: 256
 - Data width: 16
 - Message length: 21 bits (or 25 bits)
 - Message profile: Fir tree

Right-justified profile

The most significant data bit is transmitted by the encoder with the first cycle. The configured data width is monitored by the encoder driver depending on the configured message length. The maximum encoder pulses per revolution is monitored depending on the data width configured.

Configuration data:

Message length:	13/21/25 cycles can be selected
Encoder pulses per revolution:	$\leq 2^{(\text{Data width})}$
Data width:	\leq message length

3.6 Onboard measuring system interface (C230-2, C240)

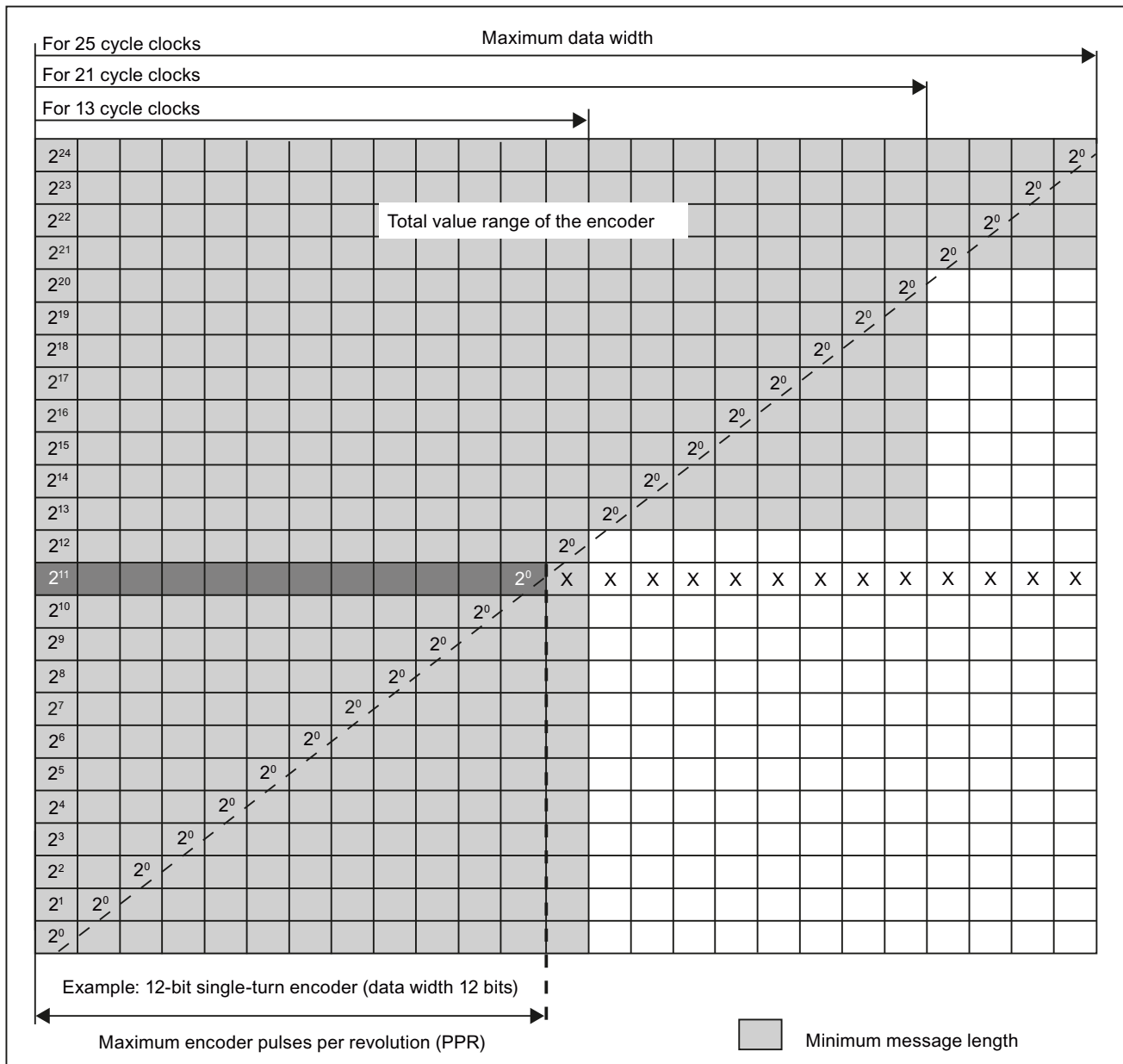

Figure 3-11 Right-justified profile

Note

Please note the following:

- The most significant data bit for the encoder's entire range of values is transmitted by the encoder with the first cycle.
 - Subsequent data bits transmitted by the encoder (or zeros) are not evaluated by SIMOTION C.
 - The encoder used in the example should be configured as follows:
 - Encoder pulses per revolution: 4096
 - Data width: 12
 - Message length: 13 bits (or 21 bits or 25 bits)
 - Message profile: Right-justified
-

Encoder supply 5 V

The 5 V supply voltage for the encoders is generated inside the module and is therefore present at the Sub-D socket. This means you can supply the encoders via the connecting cable without the need for additional wiring. The voltage supplied is protected electronically against short circuits and thermal overload, and it is monitored. The encoder supply is not isolated from the load power supply to the module.

Encoder supply 24 V

For encoders with an operating voltage of 24 V, the 24 VDC power is supplied to the Sub-D sockets. This means you can supply the encoders via the connecting cable without the need for additional wiring. The voltage supplied is protected electronically against short circuits and thermal overload, and it is monitored. The encoder supply is not isolated from the load power supply to the module.

Behavior of the integrated measurement electronics

Pulses from connected incremental encoders are quadrupled (for pulse quadruplication, see figure "Signal shapes of incremental encoders").

The actual encoder values are latched servo-synchronously in the C230-2/C240.

Note

With certain selected set values for the position control cycle clock, the measured value sampling in the C240 takes place at time T_i before the position control cycle clock time, see "Actual value latch time" table, in chapter Technical data (Page 171). This behavior is similar to that of PROFIBUS DP encoders.

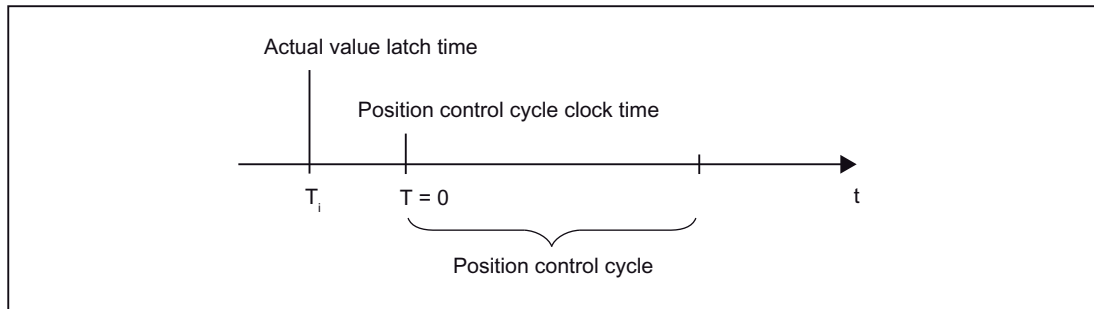

Figure 3-12 Position control cycle

Connecting cable to the encoder

The maximum cable length depends on the specification for the encoder supply and the baud rate. For problem-free operation, you must not exceed the following values when using SIEMENS preassembled connecting cables (see *Catalogs PM 21/NC 60/ST 70*):

Table 3- 14 Maximum cable lengths, depending on the encoder power supply

Supply voltage	Encoder supply voltage range	Current consumption	Max. cable length
5 VDC	4.75 V to 5.25 V	< 300 mA	25 m
5 VDC	4.75 V to 5.25 V	< 210 mA	35 m
24 VDC	20.4 V to 28.8 V	< 300 mA	100 m
24 VDC	10 V to 30 V	< 300 mA	250 m

Table 3- 15 Maximum cable lengths, depending on the baud rate

Encoder type	Frequency°	Max. cable length
Incremental encoder	1 MHz	10 m
	500 kHz	35 m
	300 kHz	100 m
Absolute encoder (SSI)	1.5 Mbits/s	10 m
	187.5 Kbyte/s	250 m

3.7 Possible uses of onboard drive and measuring system interface in the application (C230-2, C240)

3.7.1 Overview

The onboard drive interface and the measuring system interface can be used in the application for the technology objects **TO axis** and **TO externalEncoder**, and for **I/O variable**.

The table below lists the combination possibilities for the C230-2/C240.

Table 3- 16 Combination possibilities for the C230-2/C240

Application	Axis channel	
	Output (X2)	Input (X3 to X6)
Position axis	x	x
Drive axis	x	-
External encoder	-	x
Also for C240:		
Standard output (I/O variables)		
• Analog output (PQW)	x	-
• Digital output (PQ)	x	-
Standard input (I/O variables) ¹⁾		
• Counter input (PIW)	-	x

¹⁾ The incremental encoder used must not have a zero pulse

Note

A standard output and a drive **cannot** be used simultaneously on one axis channel.

The input (X3 to X6) used as a counter input cannot be used simultaneously as an encoder input.

When a project is created and when a project is downloaded, a consistency check of the permitted combinations per axis channel is automatically performed.

3.7 Possible uses of onboard drive and measuring system interface in the application (C230-2, C240)

This results in the following possibilities in the application for the C240, for example:

- Configuration of hydraulic axes on the onboard resources of the C240
- Use of unassigned axis channels of the C240 as I/O variable for the user program
- Use of the analog outputs of the C240 as unassigned process outputs

Note: The resolution and the characteristic curve of the analog output of the C240 differ from those of a SIMATIC S7 controller. The following table lists the digital values and their associated analog values (characteristic curve).

Digital value (WORD data type)	Analog value
16#7FFF \triangleq 32767	+10 V
16#0000 \triangleq 0	0 V
16#8000 \triangleq 32768	-10 V

See also

Connecting the drive units (Page 103)

3.7 Possible uses of onboard drive and measuring system interface in the application (C230-2, C240)

3.7.2 Configuration examples for C240:

Use as standard output on X2

Configuration procedure in SIMOTION SCOUT:

1. Start address is specified in the **hardware configuration**

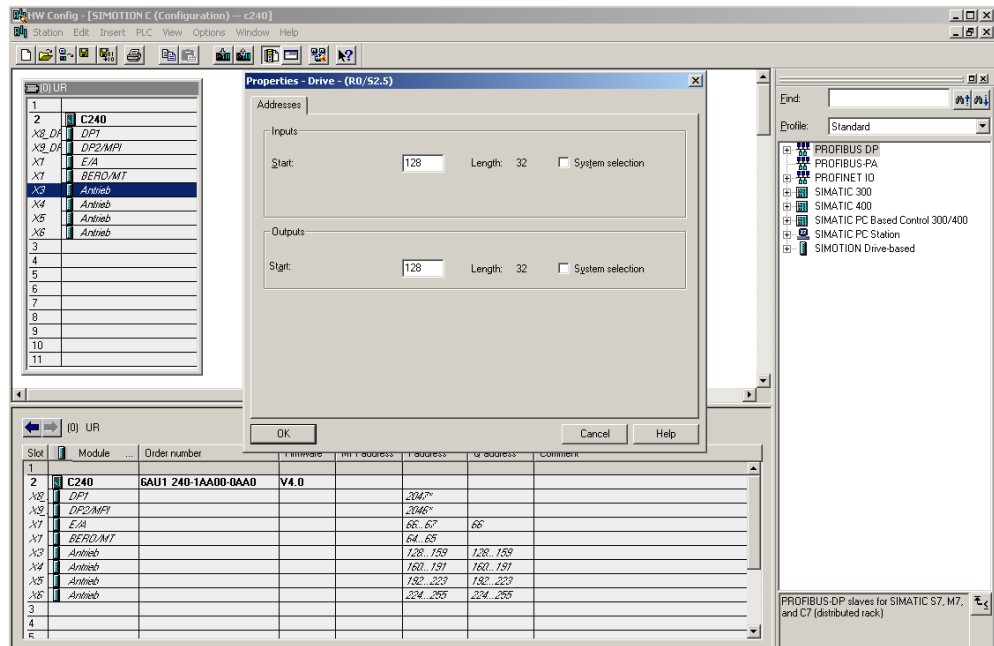

2. Specification of standard output (16-bit analog and 1-bit digital)

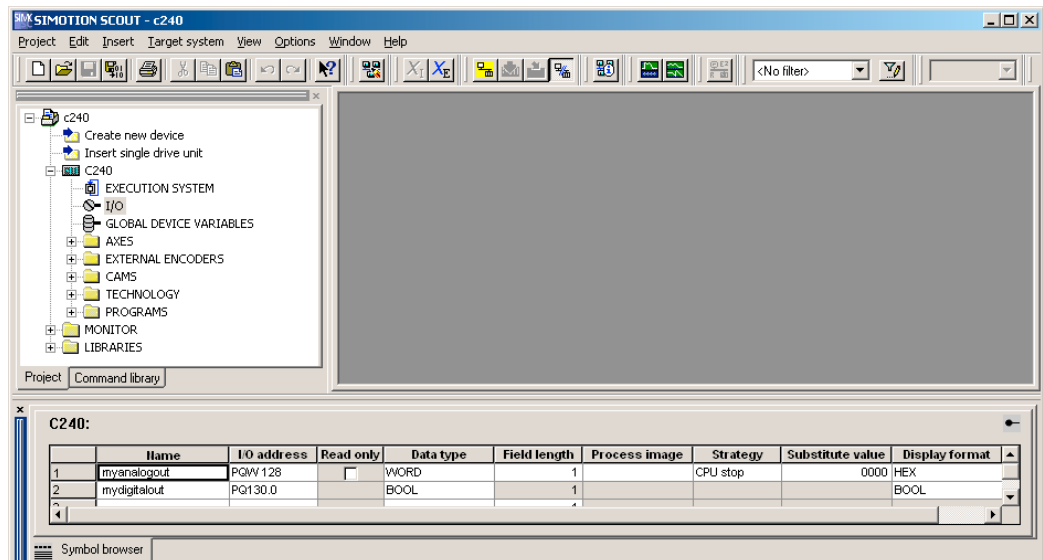

Use as counter input on X3 to X6

An available encoder input of an axis channel (e.g. for a speed-controlled axis) can be used as an input for a 16-bit up/down counter (90-degree pulse train of a connected TTL encoder, zero pulse not required). The counter value can be accessed by means of an I/O variable.

Configuration procedure in SIMOTION SCOUT:

1. Specification of start address in the **hardware configuration**.

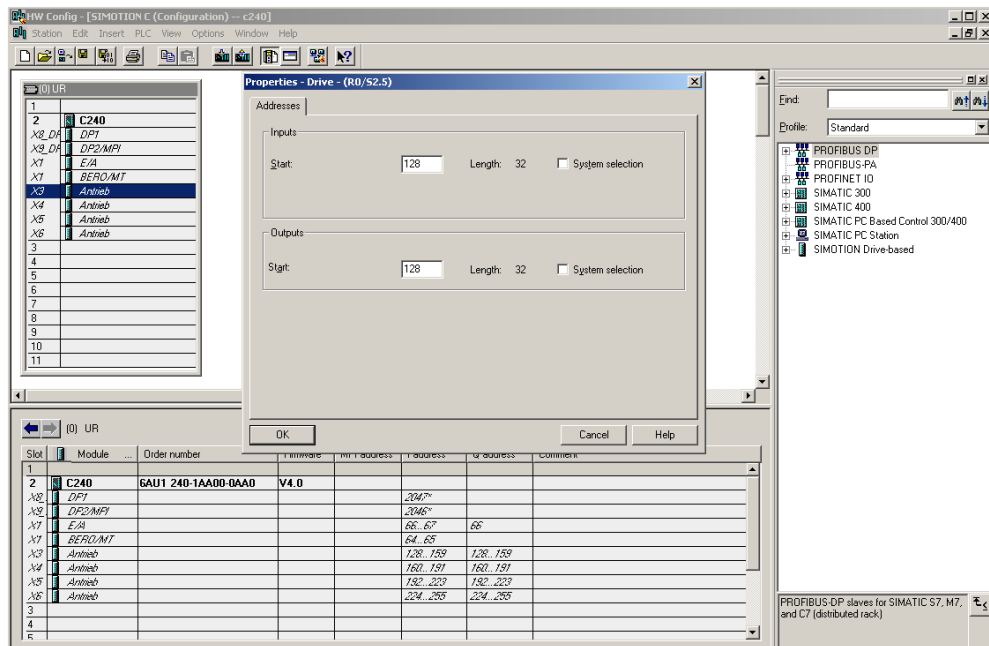

2. Use of the available encoder input as an additional counter using an incremental encoder.

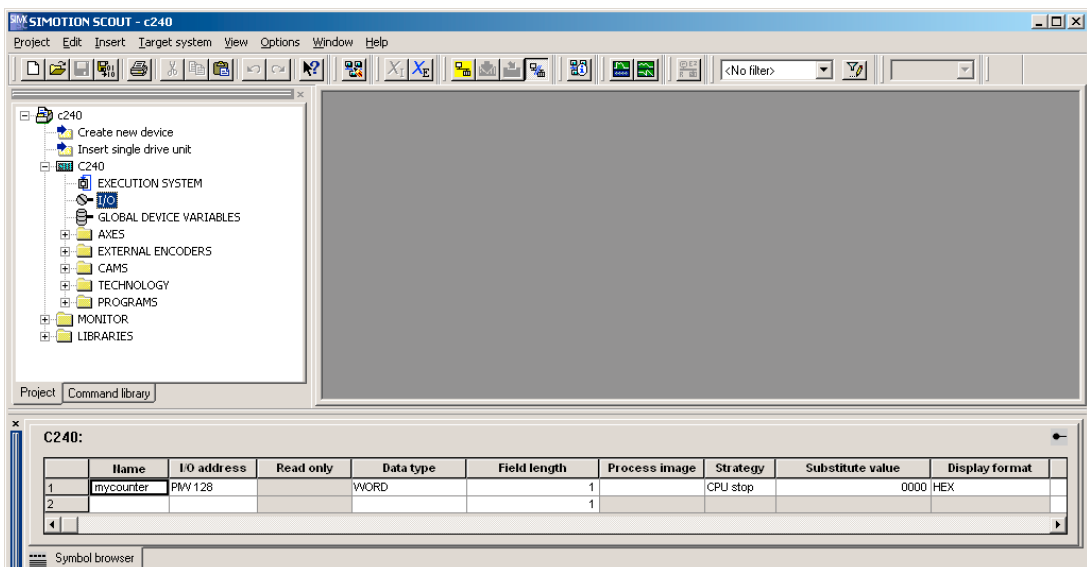

3.7 Possible uses of onboard drive and measuring system interface in the application (C230-2, C240)

Note

Use of the drive and encoder interfaces as standard outputs and counter inputs is only possible via their direct I/O address. Symbolic assignment is not available for this application.

3.8 I/O interface

Front connector

Various encoders and actuators can be connected via digital inputs and outputs to the 40-pin front connector X1 with single-wire connection.

Position of the connector

The following figure shows the position of the front connector.

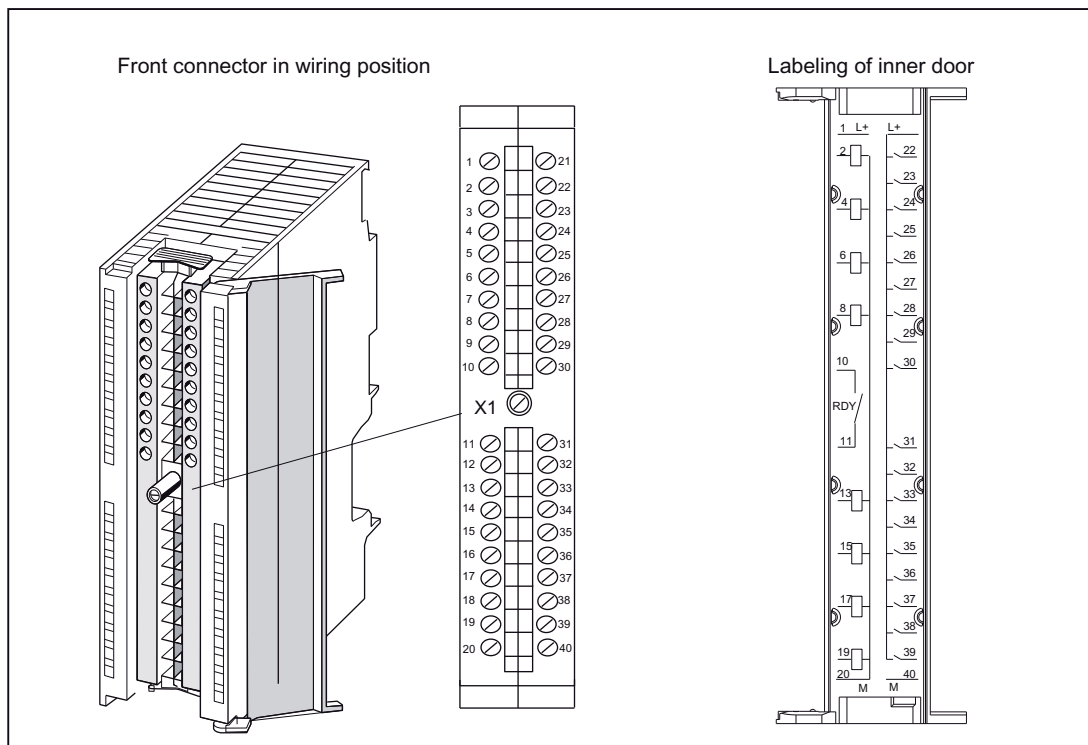

Figure 3-13 Position of connector X1

Wiring diagram and block diagram

The following figure shows the terminal diagram and block diagram for digital inputs/outputs on the SIMOTION C.

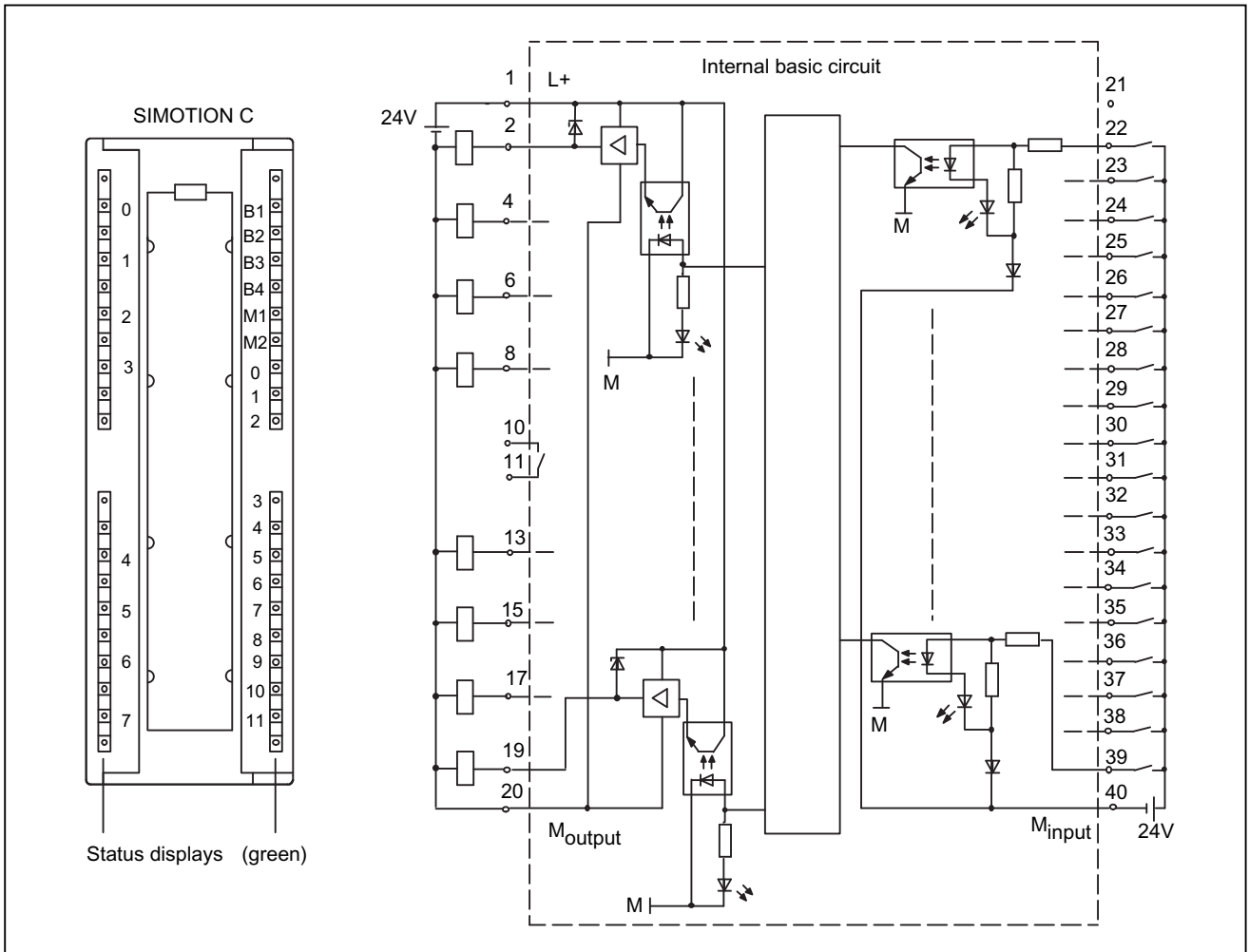

Figure 3-14 Terminal and block diagram of digital inputs/outputs on the SIMOTION C

Connector pin assignment

Connector designation: X1

Connector type: 40-pin S7 front connector for single-wire connection

Table 3- 17 Front connector X1 pin assignment

Pin	Name	Type	Pin	Name	Type
1	L+	VI	21	Unassigned	
2	Q0	DO	22	B1	DI
3	Unassigned		23	B2	DI
4	Q1	DO	24	B3	DI
5	Unassigned		25	B4	DI
6	Q2	DO	26	M1	DI
7	Unassigned		27	M2	DI
8	Q3	DO	28	I0	DI
9	Unassigned		29	I1	DI
10	RDY.1	C	30	I2	DI
11	RDY.2	C	31	I3	DI
12	Unassigned		32	I4	DI
13	Q4	DO	33	I5	DI
14	Unassigned		34	I6	DI
15	Q5	DO	35	I7	DI
16	Unassigned		36	I8	DI
17	Q6	DO	37	I9	DI
18	Unassigned		38	I10	DI
19	Q7	DO	39	I11	DI
20	M _{output}	VI	40	M _{input}	VI

Signal names

Table 3- 18 Signal names of the I/O interface

Signal name	Meaning
RDY.1 to 2	Ready (READY contact 1 to 2)
B1 to B4	<ul style="list-style-type: none"> • Inputs B1 to B4 for external zero mark signals (C230-2/C240) or • Measuring pulse inputs B1 to B4 for global measuring (C240/C240 PN) or • Digital inputs B1 to B4
M1, M2	<ul style="list-style-type: none"> • Measuring pulse inputs M1 and M2 for local measuring (C230-2/C240) or • Digital inputs M1 and M2
I0 to I11	Digital inputs 0 to 11
Q0 to Q7	Digital outputs 0 to 7
L+	Supply for digital outputs
M _{output}	Reference potential for digital outputs
M _{input}	Reference potential for digital inputs

Signal type

DI - digital input (24 V signal)
 DO - digital output (24 V signal)
 K - switching contact
 VI - voltage input

 DANGER
The 24 V power supply is to be designed as functional extra-low voltage with protective separation in accordance with EN60204-1, Section 6.4, PELV (with G ground).

Note

The connecting cable between the voltage source and the load current supply connector L+ and the associated reference potential M should not exceed a maximum length of 10 m.

Digital inputs (onboard)

The SIMOTION C has 18 digital inputs. These can also be interconnected via symbolic assignment using variables as of SIMOTION V4.2 for C240 and C240 PN.

Switches or proximity encoders (2- or 3-wire encoders) can be connected. Addresses are allocated in the hardware configuration.

The digital inputs can be used as:

- User-addressable process inputs (I0 to I11). The inputs are subject to a signal delay (see Technical data (Page 171)) and are scanned in a cycle of 125 µs.

The following inputs can be used for special functions:

- C230-2, C240: As inputs for measuring pulses for local measuring (M1, M2)

With a signal edge at the relevant input, the current actual values of one or more encoders connected to X3 to X6 are measured with positioning accuracy to determine lengths or distances.

The assignment of inputs is **not** fixed; the special use is activated in the SCOUT engineering system during configuration of the Measuring Input TO via the measuring input number.

- C230-2, C240: As inputs for external zero mark signals (B1 to B4)

With a signal edge at the relevant input, the current encoder value of the associated axis is acquired with positioning accuracy in order to record the reference coordinates.

The assignment of the inputs to the encoders is fixed, and the special use is activated in the SIMOTION SCOUT engineering system.

- B1 → axis 1 (encoder at X3)
- B2 → axis 2 (encoder at X4)
- B3 → axis 3 (Encoder at X5)
- B4 → axis 4 (encoder at X6)

- As inputs for measuring pulses for global measuring (B1 to B4) on the C240/C240 PN
Alternatively to the "external zero mark signals" function, these inputs can be used on the C240 / C240 PN for global measuring.

Note: The inputs for global measurement (B1 to B4) can be used in addition to the inputs for local measurement (M1, M2).

With a signal edge at the relevant input, the current actual values of one or more encoders are measured with positioning accuracy in order to provide information for determining lengths or distances (possible with any encoders included in the project).

The assignment of inputs is **not** fixed; the special use is activated in the SCOUT engineering system during configuration of the Measuring Input TO (see the configuration example below for global measuring).

Up to two edges can be measured for each position-control cycle clock of the Measuring Input TO.

The measured values must be read from the user program before they can be overwritten by a new measurement.

Global measuring can be used for the following applications:

- Several Measuring Input TOs on one axis/encoder where they can be active simultaneously
- Several Measuring Input TOs are assigned to one measuring input (where one Measuring Input TO is interconnected to one measuring input and the remaining Measuring Input TOs are configured as listening measuring inputs)

This functionality enables one measuring input to act on several Measuring Input TOs and thus on several axes / external encoders.

- In addition to **single measuring**, **cyclic measuring** is also supported
- Measuring on virtual axes

Note

Local measuring (onboard) on SIMOTION C

A measurement is only undertaken when there are at least 2 servo cycles between the `_enableMeasuringInput` command being called and the real switching signal expected on the probe (positive/negative flank).

In order to reliably guarantee time-critical processes, the programming should be undertaken in a synchronous task, e.g. IPO-synchronous task. It may take up to 2 servo cycles for the measurement to be available in `Messtaster.counterMeasuredValue1` after the status change in `Messtaster.actualInputState` (POSITIVE => NEGATIVE or vice versa).

When the measurement result is received, the measurement position is stored. Once the measurement has been taken, the state variable is set to `TRIGGER_OCCURRED`, and the measured values can be evaluated using the `measuredValue1` and `measuredValue2` variables for two measured edges.

The `counterMeasuredValue1` and `counterMeasuredValue2` counter variables are defined for the `measuredValue1` and `measuredValue2` system variables and are automatically incremented by a value of one for each measurement input. New results can be traced immediately and can also be read from non-IPO-synchronous tasks.

You will find detailed information on this subject in the SIMOTION Function Manual *Output Cams and Measuring Inputs*.

Configuration example for global measuring

Configuration procedure in SIMOTION SCOUT:

The measuring input must be configured as follows:

1. Activate global measuring.
2. Assign to the input e.g. PI 64.0 or use symbolic assignment (e.g. C240.B1 [B1, X1.22]).

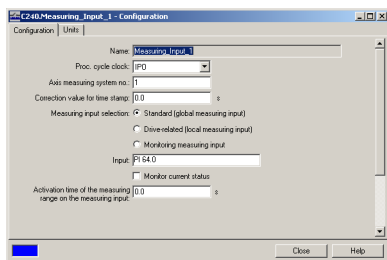

Figure 3-15 Configuration example for global measuring (without symbolic assignment)

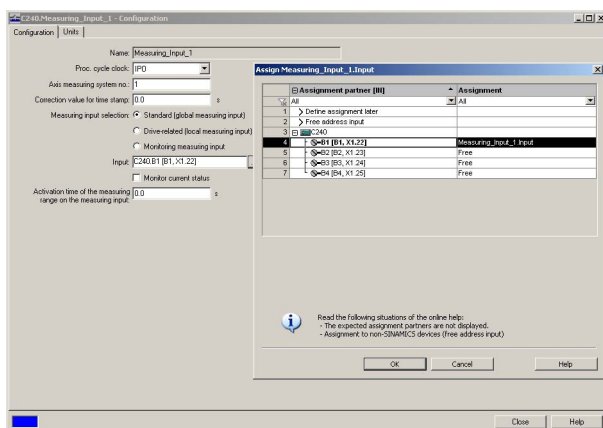

Figure 3-16 Configuration example for global measuring (symbolic assignment)

With a signal edge at the measurement input, the current actual value of the assigned encoder is recorded with an exact position.

Digital outputs (onboard)

Eight digital outputs (Q0 to Q7) are provided on the SIMOTION C. These can also be interconnected via symbolic assignment using variables as of SIMOTION V4.2 for C240 and C240 PN.

These fast outputs (onboard) can be used as freely addressable process outputs or as "fast output cams" (position switching signals). Addresses are allocated in the hardware configuration. The outputs are subject to a signal delay, see Technical data (Page 171).

For repeat accuracy when using the outputs as fast output cams, see Versions of SIMOTION C (Page 29).

READY output

The ready signal (RDY.1, RDY.2) is an isolated contact assembly (make contact).

The contact can be used for the safe shutdown of parts of the system, for example, through integration in the EMERGENCY STOP circuit.

The following table describes the states of the enables and outputs in the respective SIMOTION C operating states with an open or closed READY contact.

Table 3- 19 Statures of enable signals and outputs:

Status of the READY contact	SIMOTION C	Status of enable signals and outputs:
Open	<ul style="list-style-type: none"> • During ramp-up • During memory reset • With fault condition • In STOP mode • In STOPU mode 	<ul style="list-style-type: none"> • Controller enable deactivated • Analog outputs at 0 V • Digital outputs deactivated
Closed	<ul style="list-style-type: none"> • in RUN mode 	Enable signals and outputs controlled by user program and technology

Additional references

You can find information about TO outputCam and Measuring Input TO in the *SIMOTION Output Cams and Measuring Inputs* Function Manual.

Configuring and installing

4.1 General requirements

Overview

In this chapter we will explain how to design the mechanical configuration, prepare the SIMOTION components for installation and install them.

During the installation of SIMOTION C modules, you must pay attention to the electrical configuration. Therefore, also refer to the chapter Wiring (Page 91).

Open equipment

These modules are open equipment. This means they may only be installed in housings, cabinets or in electrical service rooms that can be entered or accessed exclusively by means of a key or tool. Housings, cabinets or electrical service rooms may only be accessed by trained or authorized personnel.

4.2 Configuring an installation using SIMOTION C modules

4.2.1 Horizontal and vertical configuration

Design

You can install the rack either horizontally or vertically. The horizontal configuration should be used if possible.

Permissible ambient temperature

- Horizontal installation: 0 °C to 55 °C
- Vertical installation: 0 °C to 40 °C

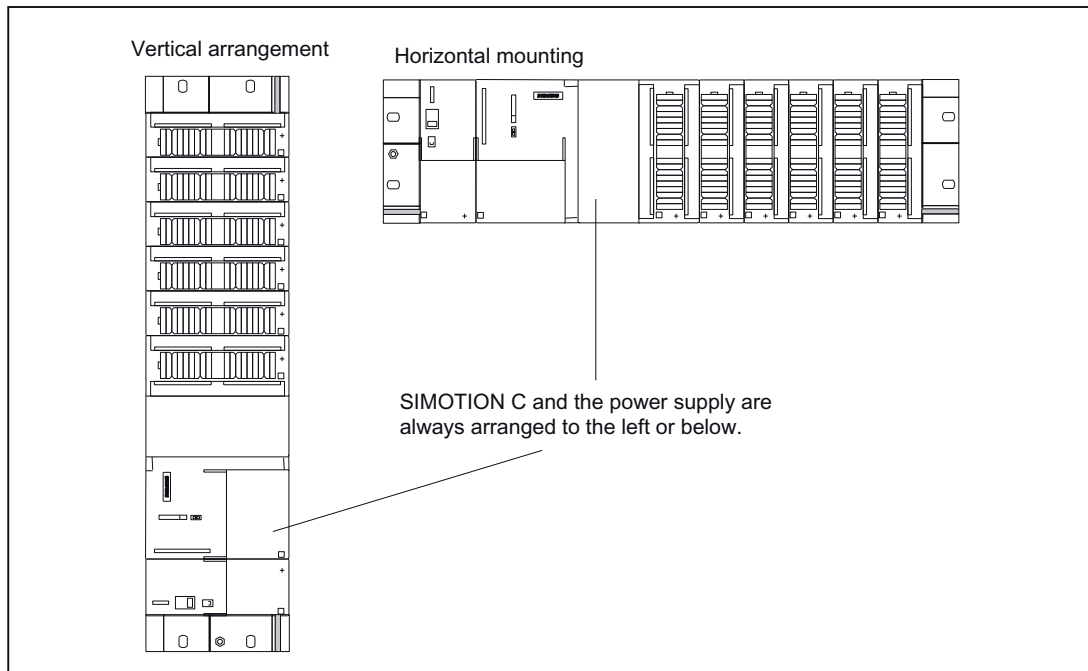

Figure 4-1 Horizontal and vertical configuration

4.2.2 Clearances

Rules

If you comply with the minimum clearances, you will:

- Ensure heat is dissipated from the modules
- Provide space to fit and remove modules
- Provide space to lay wiring
- Increase the mounting height of the rack to 205 mm!

To guarantee the functionality, clearances of 40 mm must be maintained.

Note

If you use a shield connecting element, the dimensions stated are measured from the lower edge of the shield connecting element.

Clearances

The following figure shows the clearances between the individual racks and the clearance to adjacent equipment, cable ducts, cabinet walls, etc.

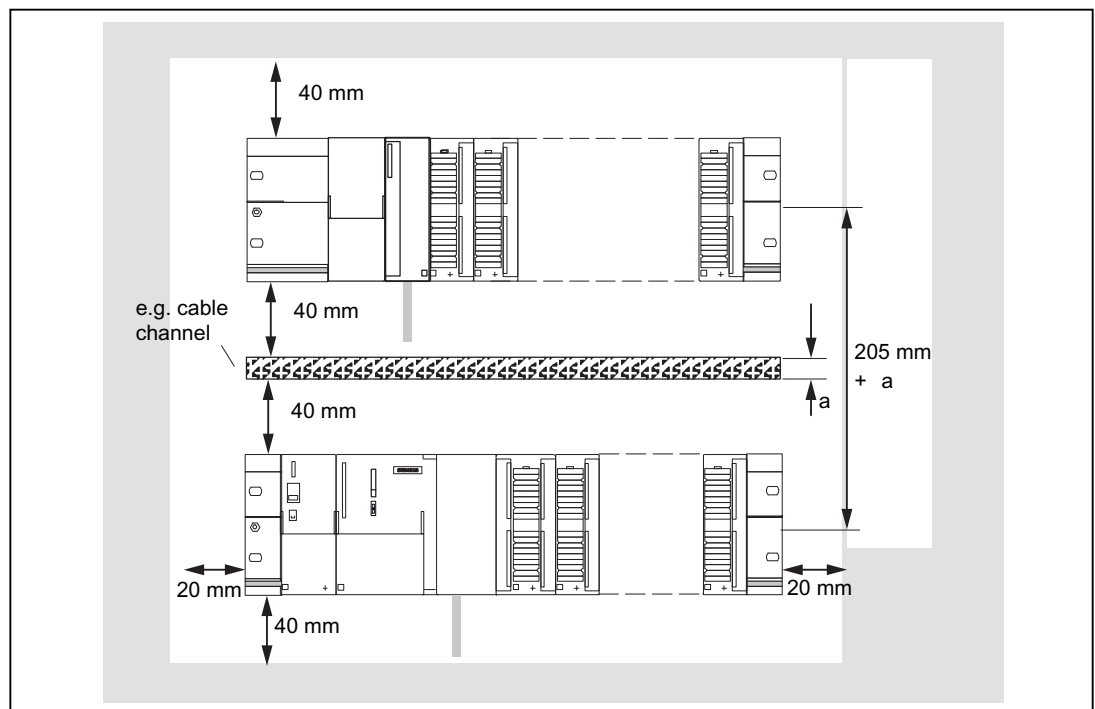

Figure 4-2 Clearances

4.2.3 Mounting dimensions of modules

Overview of mounting dimensions

The following table shows the mounting dimensions of modules.

Table 4- 1 Mounting dimensions of modules

Modules	Module width	Module height	Maximum mounting depth
Power supply PS 307, 2 A	50 mm	125 mm, 185 mm with shield connecting element	130 mm or 180 mm with an open front cover of the SIMOTION C
Power supply PS 307, 5 A	80 mm		
Power supply PS 307, 10 A	200 mm		
SIMOTION C	200 mm		
Signal modules (SMs)	40 mm		
Function modules (FM)	40 mm or 80 mm		
Communications processors (CP)	40 mm		

Mounting rail lengths

Depending on the configuration you have chosen, you can use the following mounting rails:

Table 4- 2 Mounting rails

Mounting rail	Usable length for modules	Comments
160 mm	120 mm	Mounting holes are provided
482.6 mm	450 mm	Mounting holes are provided
530 mm	480 mm	Mounting holes are provided
830 mm	780 mm	Mounting holes are provided
2,000 mm	Cut to required length	Mounting holes must be drilled

4.2.4 Layout of modules on a rack

Rules

The following rules apply with respect to the layout of the modules on a rack:

- Up to eight modules can be inserted to the right of the SIMOTION C.
- The number of plug-in modules is also limited by their power consumption from the backplane bus (see Technical data table for the individual modules in the *S7-300 Automation Systems, M7-300 Module Data Manual*).

The total power consumption from the backplane bus of all modules that are mounted on a rack must not exceed 1.2 A.

This figure shows the order of the modules in an installation with eight I/O modules.

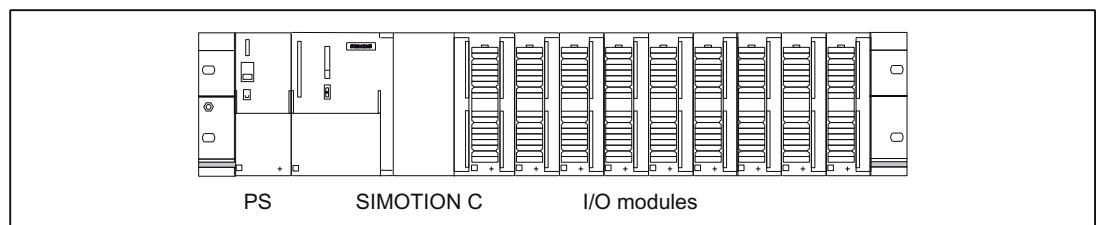

Figure 4-3 Layout of modules on a rack

Installation of FM STEPDRIVE

The FM STEPDRIVE modules can be installed, in addition to the eight SMs. They have no connection to the backplane bus and must therefore only be taken into consideration with regard to the module width. In order to prevent the backplane bus from being interrupted, the FM STEPDRIVE modules must always be configured as the last modules on the module rack.

4.2.5 Layout of modules on several racks

Overview

With the SIMOTION C, a 2-tier layout is possible.

Interface modules

Interface modules are required for the 2-tier layout which route the backplane bus from one rack to the other. The SIMOTION C is always located on rack 0.

Table 4- 3 Interface modules

Interface module	Usable for ...	Order number
IM 365 SEND	Rack 0	6ES7 365-0BA01-0AA0
IM 365 RECEIVE	Rack 1	

IM 365 interface modules

The two IM 365 interface modules have a fixed connection via a 1-meter long connecting cable.

The total power consumption of the inserted I/O modules of both racks must not exceed 1.2 A; the power consumption from rack 1 is limited to 800 mA.

Rules

The following rules apply with respect to the layout of the modules on two racks:

- The interface module always occupies Slot 3 and is always left of the first signal module.
- No more than eight modules may be inserted per rack. These modules are always to the right of the interface modules.
- The number of inserted modules is limited by the permissible power consumption from the backplane bus. Total power consumption must not exceed 1.2 A (see Technical data table for each module in the manual *S7-300 Automation System, M7-300 Module Data*).

2-tier layout

The figure below shows the 2-tier layout with SIMOTION C.

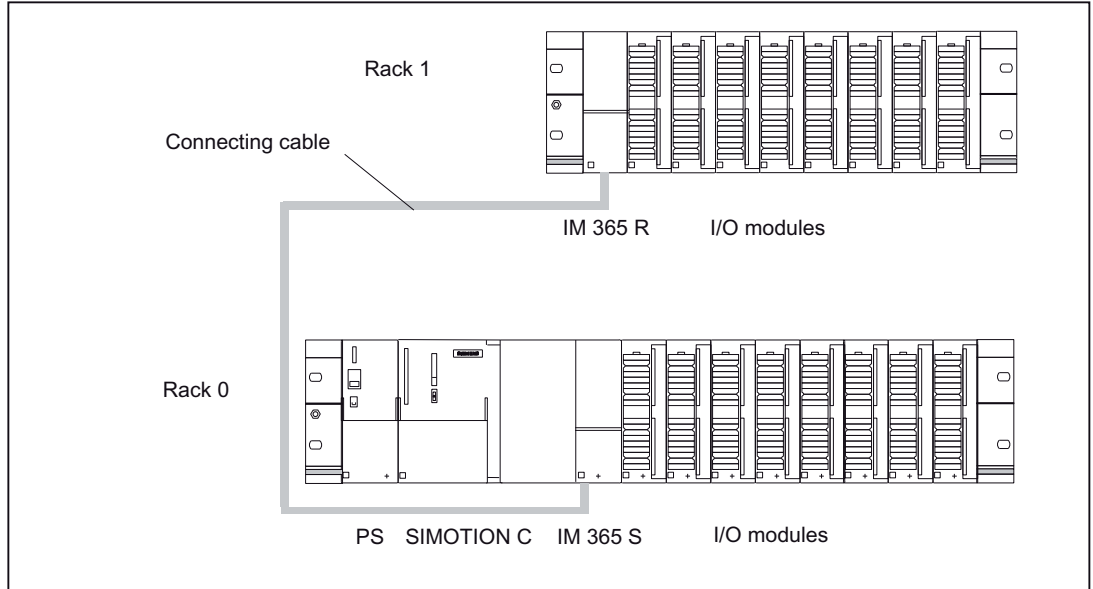

Figure 4-4 Layout of modules on two racks

4.3 Installing

4.3.1 Installing mounting rails

Installing a 2-meter mounting rail

You must prepare the 2-meter mounting rail for installation. Proceed as follows:

1. Shorten the 2-meter mounting rail to the required dimension.
2. Mark in
 - Four holes for mounting screws (dimensions: see table below)
 - One hole for a protective conductor mounting screw.
3. Is the mounting rail longer than 830 mm?
If so: you must drill additional holes for more mounting screws to stabilize the mounting rail. Mark out these holes along the groove in the middle section of the rail (see the figure below). These additional holes should be spaced approximately every 500 mm.
If not: no additional work required.
4. Drill the $6.5^{+0.2}$ mm-diameter holes where marked for M6-size screws.
5. Fit an M6 screw to secure the protective conductor.

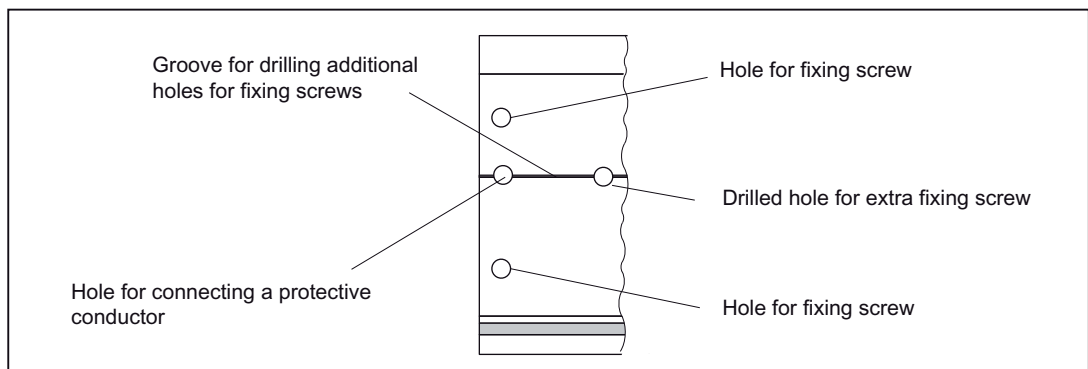

Figure 4-5 Mounting holes in a 2-meter mounting rail

Dimension drawing for mounting holes

The mounting hole dimensions for the mounting rail are shown in the table below.

Table 4- 4 Mounting holes for rails

"Standard" mounting rail			2-meter mounting rail
Mounting rail length	Distance a	Distance b	-
160 mm	10 mm	140 mm	
482.6 mm	8.3 mm	466 mm	
530 mm	15 mm	500 mm	
830 mm	15 mm	800 mm	

Mounting screws

Choose one of the following types of screw to mount the mounting rail:

Table 4- 5 Mounting screws

For	you can use...	Explanation
Outer mounting screws	M6 cylinder-head screw per ISO 1207/ISO 1580 (DIN 84/DIN 85)	Select a screw length that is appropriate to your configuration
	M6 hexagonal screw per ISO 4017 (DIN 4017)	You also need 6.4 mm washers per ISO 7092 (DIN 433)
Additional mounting screw (2-meter mounting rail only)	M6 cylinder-head screw to ISO 1207/ISO 1580 (DIN 84/DIN 85)	

Installing mounting rails

Install the mounting rails as follows:

1. Fit the mounting rail in a position that will allow enough room for the modules to be installed and for the heat to dissipate (a minimum of 40 mm above and below the mounting rail; see Figure "Clearance distances").
2. Screw the mounting rail onto the surface where it is to be affixed (screw size: M6). Is this substrate a grounded metal plate or a grounded equipment mounting plate?
If so: make sure that there is a low-resistance connection between the mounting rail and the substrate. Use suitable electro-lubricant or contact washers with painted and anodized metals, for example.
If not: no special action required.
3. Connect the mounting rail with the protective conductor. An M6 protective conductor screw is provided on the mounting rail for this purpose.
Minimum cross-section of protective conductor line: 10 mm².

Note

Always make sure that there is a low-resistance connection to the protective conductor (see figure below). If the rack is mounted on a movable frame, for example, make sure that the line to the protective conductor is flexible.

PE connection

The figure below shows the proper way of connecting the protective conductor to the mounting rail.

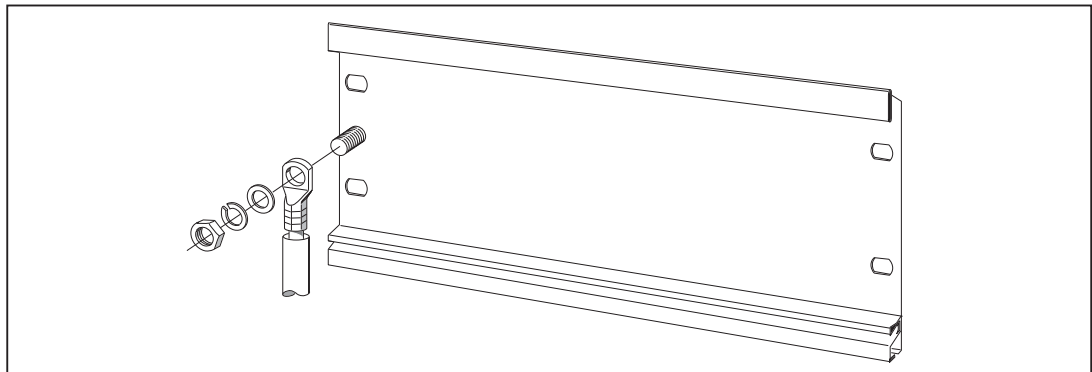

Figure 4-6 Protective conductor connection on the mounting rail

4.3.2 Fitting modules on the mounting rail

Accessories

Any accessories you need for installation are in the pack with the modules. Chapter Spare parts and accessories (Page 184) contains a list of accessories and spare parts together with the corresponding order numbers.

Table 4- 6 Module accessories

Module	Accessories supplied	Explanation
SIMOTION C	One slot number plate	For the assignment of slot numbers
	Two keys (C230-2)	The key is used to operate the mode selector for the C230-2.
	One labeling plate	For labeling of integrated inputs and outputs of the SIMOTION C
Signal module (SM)	One bus connector	To provide the electrical connections between the modules
	One labeling plate	To label the inputs and outputs on the module

Sequence in which modules are affixed to the mounting rail

1. Power supply module
2. SIMOTION C
3. Signal module(s)

Installation sequence

The individual steps for the installation of the modules are described below:

1. Except for the SIMOTION C, each signal module is supplied with a bus connector. When plugging in the bus connectors, always start with the SIMOTION C. Take the bus connector from the next module and plug it into the bus connector of the SIMOTION C. (The bus connector is located on the rear side, see Figure "Position of interfaces and front panel elements"). You must not plug a bus connector into the "last" module in the row.
2. Fit the modules by hooking them into position, push them against the left-hand module and lower them down into position.
3. Screw down the modules, applying a torque of 0.8 to 1.1 Nm.

4.3.3 After installation

Inserting the key (C230-2)

Once the C230-2 has been mounted on the mounting rail, you can insert the key in the STOP or STOPU position on the C230-2.

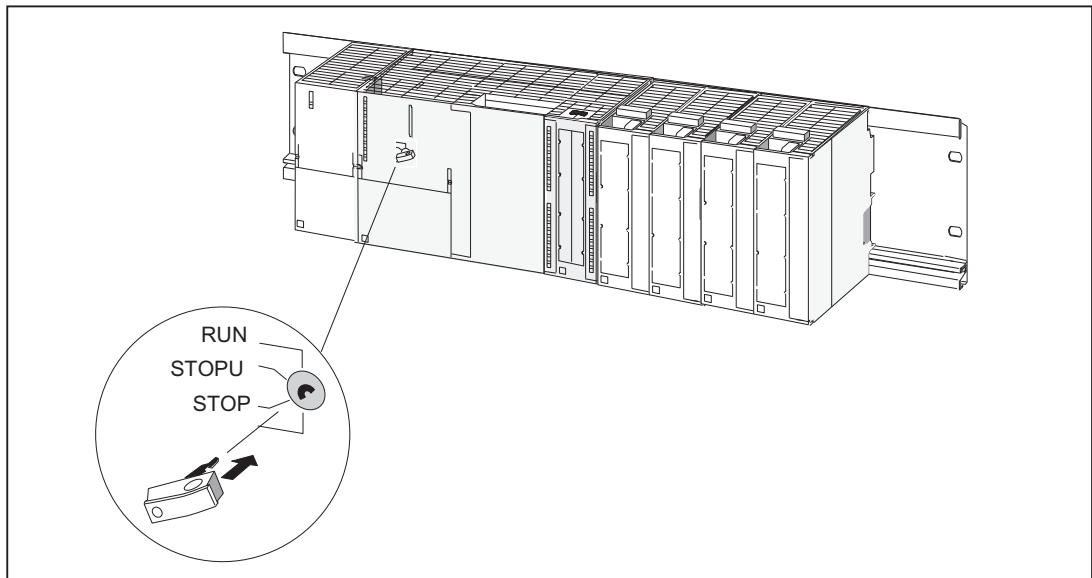

Figure 4-7 Inserting the key in the C230-2

Assigning the slot numbers

After mounting, you can assign each module a slot number. This eases the assignment of the modules to the configuration table in the *Engineering System*. The table below shows the slot number assignment.

Table 4-7 Slot numbers for S7 modules and SIMOTION C

Slot no.	Module	Comments
1	Power supply (PS)	-
2	SIMOTION C	-
3	Reserved	-
4	1. I/O module	To the right of SIMOTION C
5	2. I/O module	-
6	3. I/O module	-
7	4. I/O module	-
8	5. I/O module	-
9	6. I/O module	-
10	7. I/O module	-
11	8. I/O module	-

Inserting slot numbers

This figure shows the proper way of inserting the slot numbers. The slot number labels are included with the SIMOTION C.

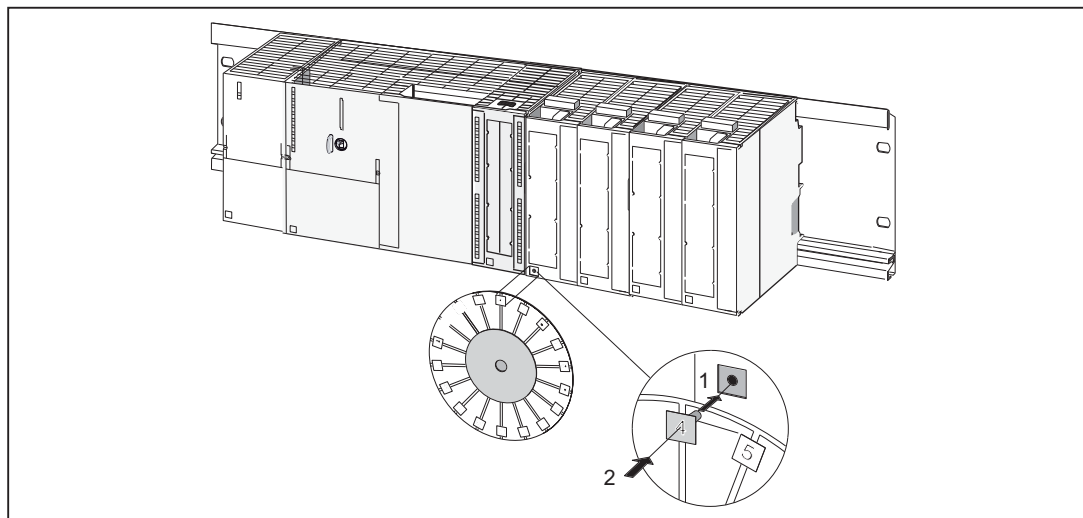

Figure 4-8 Inserting slot numbers on the modules

Connecting

5.1 Wiring

5.1.1 General requirements for wiring

Basic rules

Because of the wide range of uses of a SIMOTION C, only the basic rules for electrical installation can be included in this section. At a minimum, you must comply with these basic rules to ensure problem-free operation.

Safety regulations

In order to ensure safe operation of your equipment, implement the following measures, adapting them to suit your conditions:

- An EMERGENCY OFF concept in accordance with the generally accepted rules of current engineering practice (e.g. European standards EN 60204, EN 418, and similar).
- Additional measures for end position limiting of axes (e.g. hardware limit switches).
- Equipment and measures for protection of motors and power electronics in accordance with the installation guidelines of the used drive units.

In addition, in order to identify hazards, we recommend that a risk analysis be conducted on the entire system in accordance with the basic safety requirements set out in Appendix 1 of EU Machinery Directive 89/392/EEC.

Additional references

Please also note the information in the following sections of this manual:

- Guidelines on Handling Electrostatic Sensitive Devices (ESD guidelines)
- For additional information on installing a system containing S7-300 process I/O, refer to the "Wiring" section of the *S7-300 Automation System, Hardware and Installation, CPU Data Manual*.

Standards and specifications

When wiring the SIMOTION C, you must observe the appropriate VDE guidelines, in particular VDE 0100 and VDE 0113 for tripping devices and short-circuit and overload protection.

5.1.2 Configuring the electrical installation

General rules for operating a SIMOTION C

You must observe the following primary rules for integrating a SIMOTION C in an automation system or plant.

System startup after certain events

The following table identifies considerations required for startup of a system following certain events.

Table 5- 1 System startup

If there is ...	Then ...
Startup after voltage drop or power failure	All hazardous operating conditions must be avoided. If necessary, force an EMERGENCY STOP.
Startup after releasing the EMERGENCY STOP apparatus	must always be controlled and defined.

Supply voltage

The following table identifies the considerations required for the supply voltage.

Table 5- 2 Supply voltage

Scope	Requirement
Stationary systems without all-pole power disconnect switches	A power disconnect switch or a fuse must be provided in the electrical installation for the building.
Load power supply, power supply modules	The set rated voltage range corresponds to the local supply voltage.
All electric circuits	The fluctuation/deviation of the supply voltage from the rated value must be within the permissible tolerance (see Technical data for S7-300 modules).

24 VDC supply

The following table identifies the considerations required for the 24 V supply.

Table 5- 3 24 V supply

Scope	Requirement	
buildings	external lightning protection.	Take lightning protection measures
24 V DC supply lines, signal lines	internal lightning protection	(e.g. lightning conductors).
24 V supply	Safe (electrical) isolation of extra-low voltage	

Protection from external electrical influences

The following table identifies the considerations required for protection against external electrical phenomena or faults.

Table 5- 4 Protection against external electrical phenomena

Scope	Requirement
All plants or systems in which the SIMOTION C or S7-300 is installed	The equipment or system is connected to a protective conductor to discharge electromagnetic interference.
Supply, signal, and bus lines	The wiring arrangement and installation complies with EMC regulations.
Signal and bus lines	A wire or conductor strand break must not cause any undefined installation or system states.

Rules for current consumption and heat loss in a central configuration

The I/O modules on the I/O bus take the current required for their operation from the I/O bus as well as, when necessary, from an external load power supply.

- The current consumption of all I/O modules from the I/O bus must not exceed 1.2 A. This is the current that the SIMOTION C can supply on the I/O bus.
- PS 307 power supply modules are available for different loads (2 A, 5 A, 10 A). The selection of the appropriate power supply depends on the sum of the current consumption of the SIMOTION C, the connected I/O modules and any other connected loads fed by the load power supply.
- The power loss of all components used in a cabinet must not exceed the maximum amount that can be dissipated from the cabinet.

Tip: When selecting the cabinet design, make sure that the temperature in the cabinet will not exceed the permissible ambient temperature for the installed components, even if the outside temperatures are high.

You will find information on the current consumption and heat loss of a module in the technical data of the corresponding modules.

 DANGER
All interfaces of the SIMOTION C must operate only on circuits with safety extra-low voltage (SELV).

Pulling out and inserting I/O-bus I/O

I/O-bus I/O must not be pulled out or inserted during operation.

Note

The I/O bus will not work if I/O-bus I/O are pulled out during operation. The SIMOTION must be switched off and back on again when these are reinserted.

5.1.3 Overview of wiring diagram

C230-2/C240 with servo drive (analog connection)

The figure below shows how the individual components are connected to the C230-2/C240 and the servo drive (analog connection).

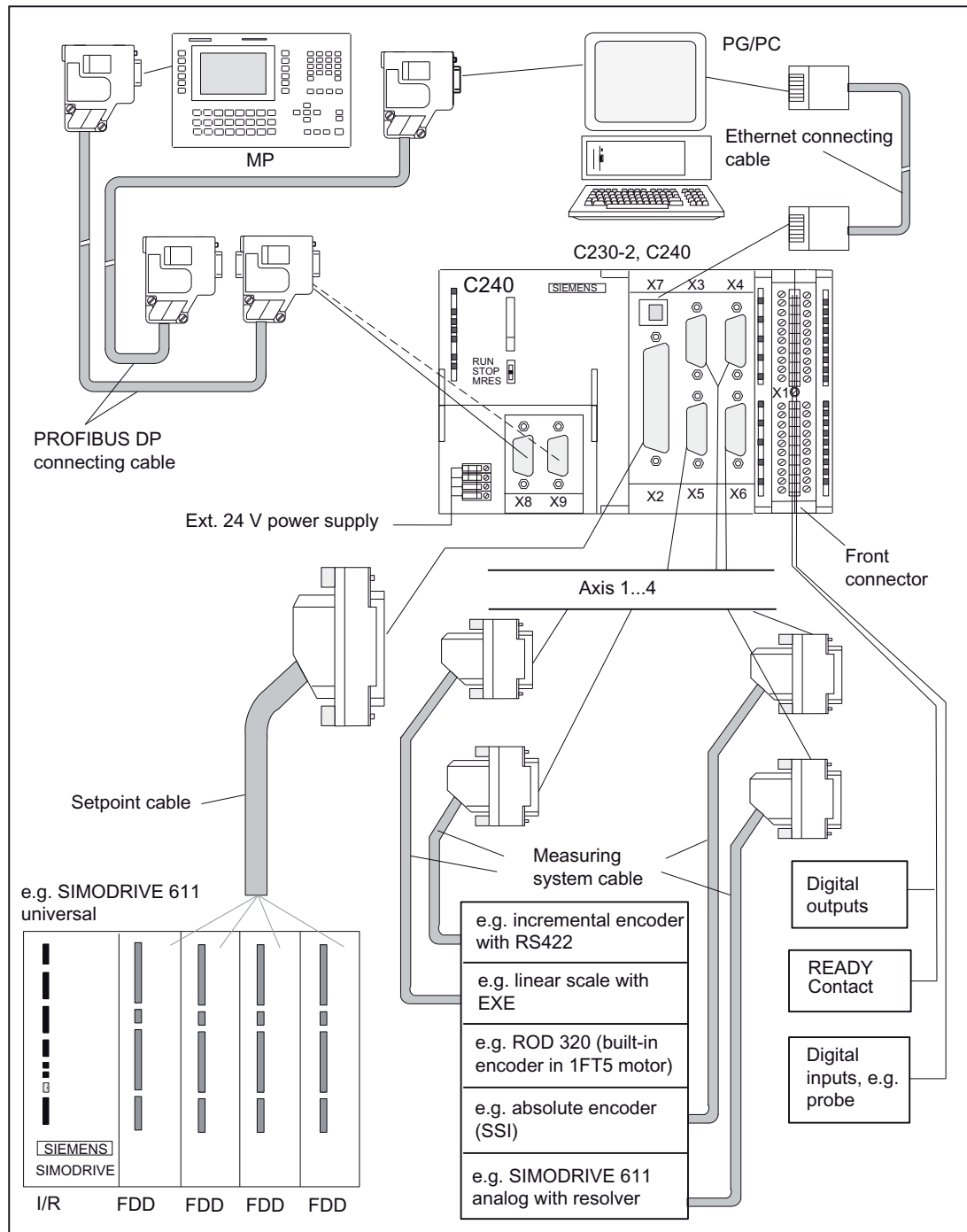

Figure 5-1 Overview of the cable connecting the C230-2/C240 to the servo drive (analog coupling) - example

SIMOTION C with servo drive (digital connection) via PROFIBUS DP

The figure below shows how the individual components are connected to the SIMOTION C and the servo drive (digital connection).

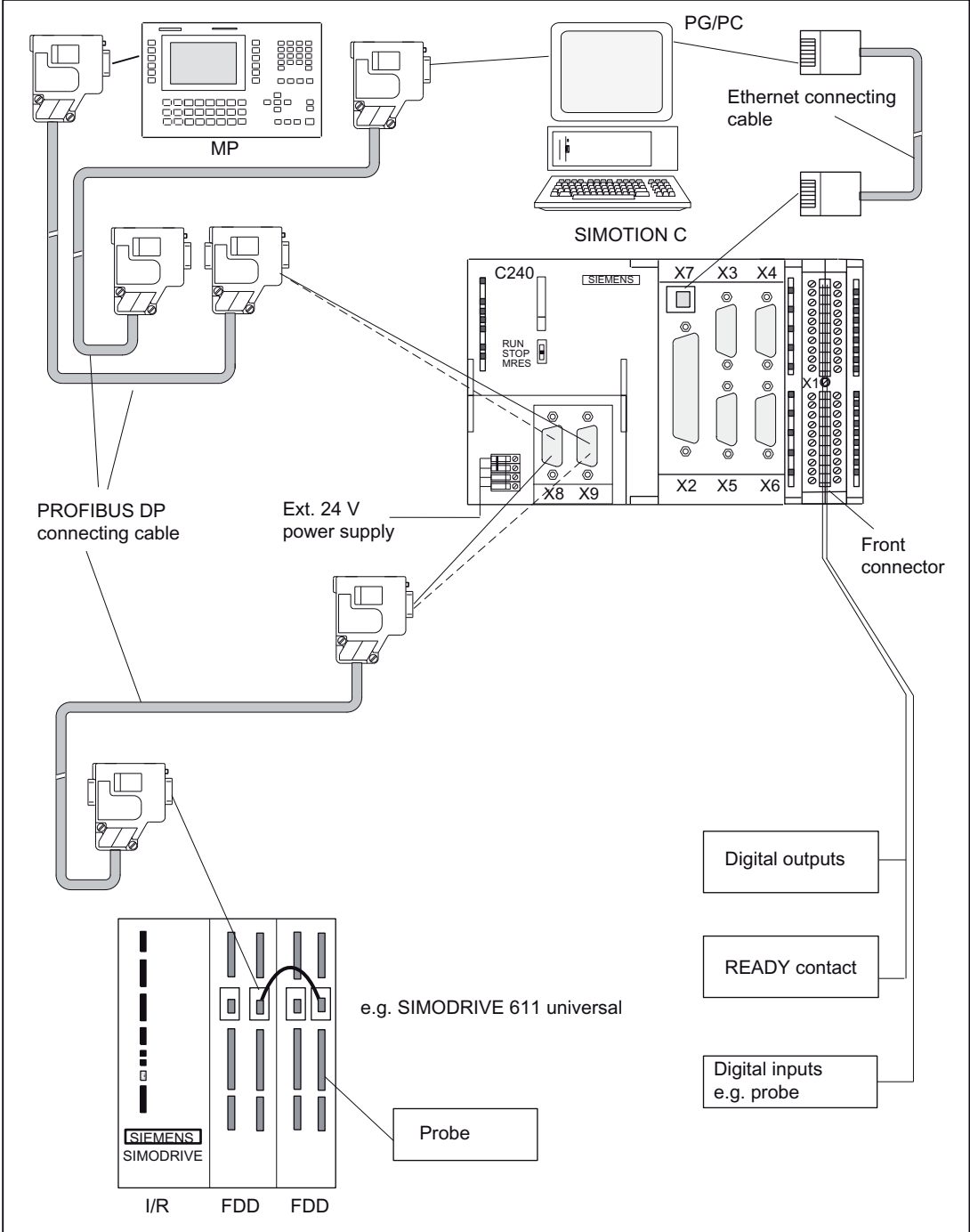

Figure 5-2 Overview of the cable connecting the SIMOTION C to the servo drive (digital connection) - example

C240 PN with servo drive (digital connection) via PROFINET IO

The figure below shows how the individual components are connected to the C240 PN and the servo drive (digital connection).

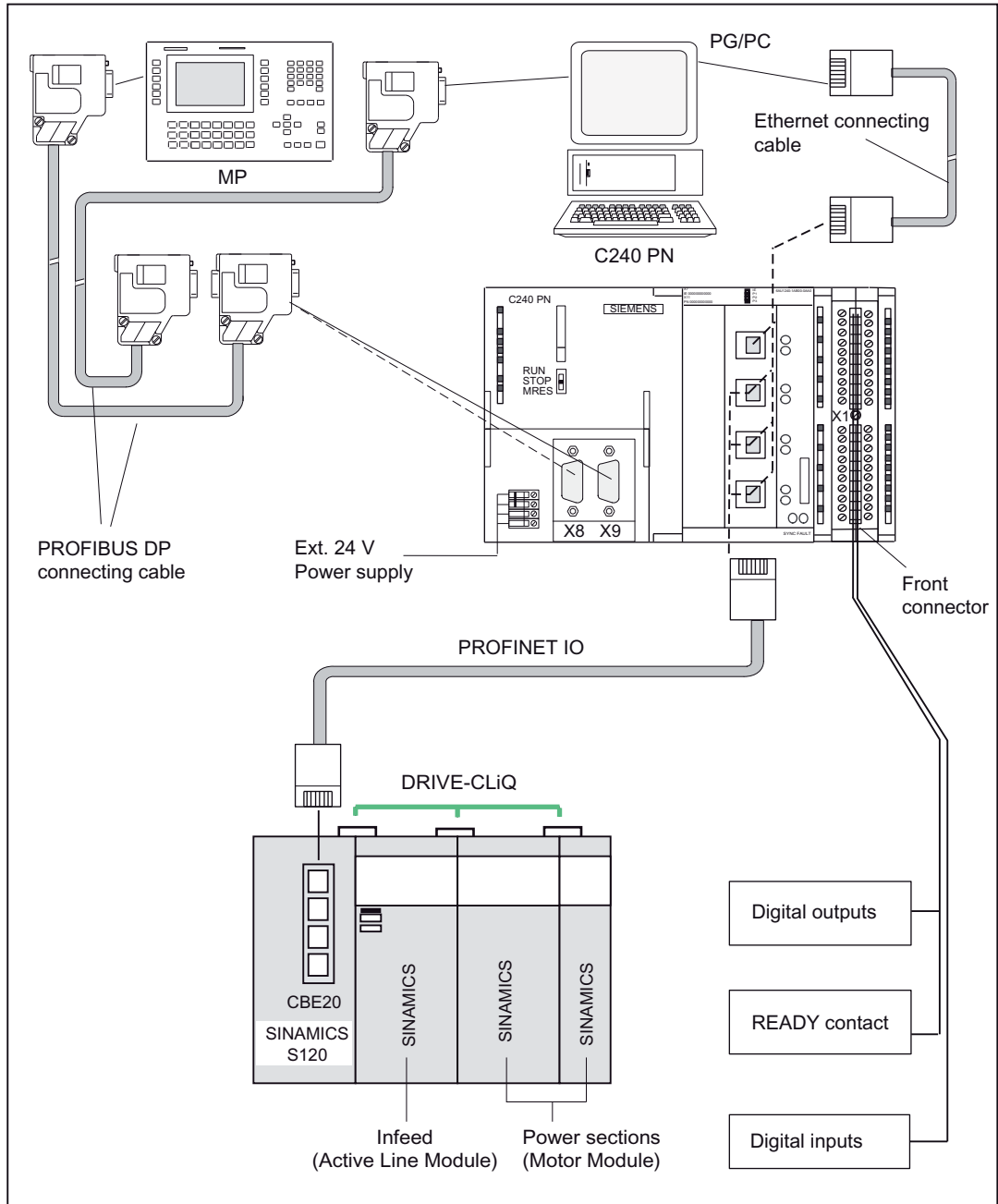

Figure 5-3 Overview of the cable connecting the C240 PN to the servo drive (digital connection) - example

C230-2, C240 with stepper drive

The figure below shows how the individual components of the multi-axis controller are connected to the C230-2, C240 and stepper drive.

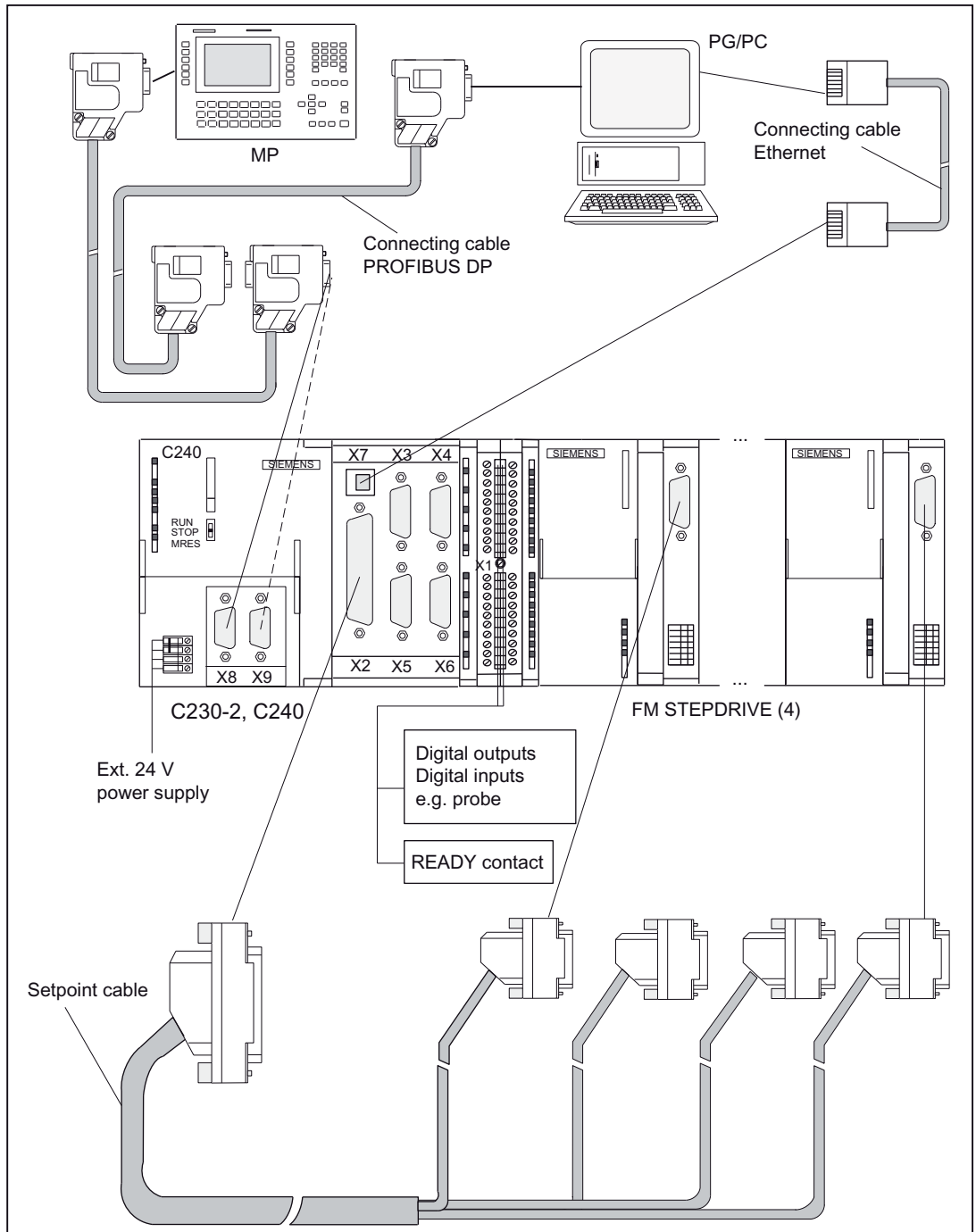

Figure 5-4 Overview of the cable connecting the C230-2/C240 to the stepper drive - example

Overview of connections - connecting cable

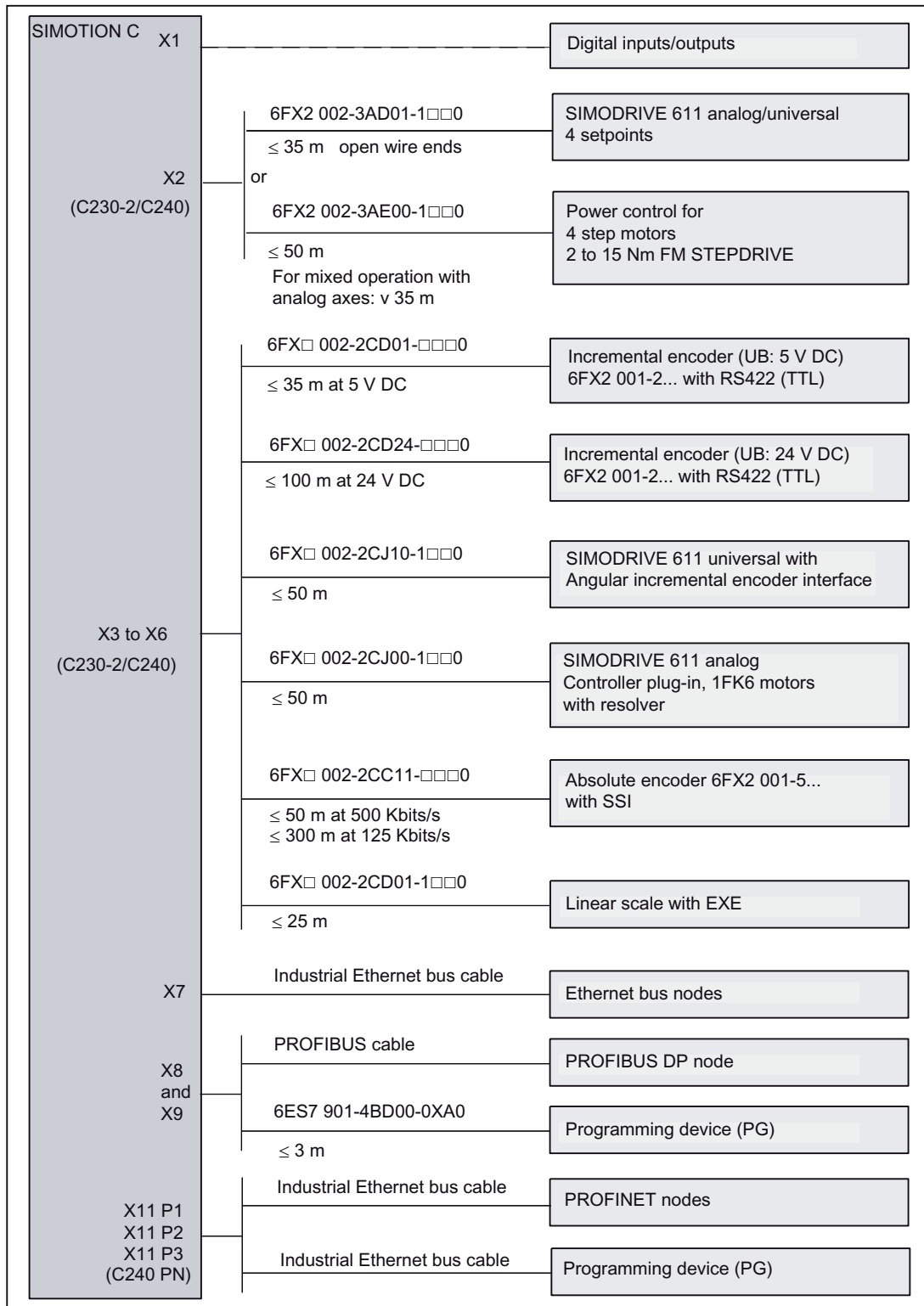

Figure 5-5 Overview of SIMOTION C connections

The setpoint and measuring system cables (see figure "Overview of connections") are available in various lengths.

See *PM 21 Catalog / NC 60 Catalog / ST 70 Catalog / CA 01 Catalog*

For information about the PROFIBUS cable or Ethernet bus cable, see chapter Networking (Page 122).

For additional information about PROFIBUS DP, PROFINET IO and Ethernet, see *IK PI Catalog*

Front connector

For the wiring of the digital inputs/digital outputs, you need a 40-pole front connector (screw type or spring tension type). This must be ordered separately.

Order no.: Screw type 6ES7 392-1AM00-0AA0

Spring type 6ES7 392-1BM01-0AA0

See *ST 70 catalog/NC 60 catalog*

5.1.4 Connecting the power supply

Screw-type terminal block

The required 24 VDC load power supply is connected at the screw-type terminal block.

Properties of the load power supply



DANGER

The 24 VDC should be configured as functional extra-low voltage with safe isolation.

Note

The connecting cable between the voltage source and the load current supply connector L+ and the associated reference potential M should **not** exceed a maximum length of 10 m.

Table 5- 5 Electrical parameters of load power supply

Parameters	min	max	Unit	Conditions
Voltage range - mean value	20.4	28.8	V	
Ripple		3.6	V _{pp}	
Transient overvoltage	35	35	V	500 ms duration 50 s recovery time
Rated current consumption		2.2	A	see "Connection values" table in chapter Technical data (Page 171)
Starting current		8	A	

Pin assignment

The table below shows the pin connections on the screw-type terminal block.

Table 5- 6 Assignment of the screw-type terminal block

Terminal	Pin assignment
	Functional ground
M	Ground
L+	DC 24 V
M	Ground

If you want to ground the reference potential, you must **not** remove the jumper between terminals M and functional ground on the SIMOTION C.

Line buffering

The PS 307 load current supplies from the S7-300 system guarantee mains buffering for 20 ms.

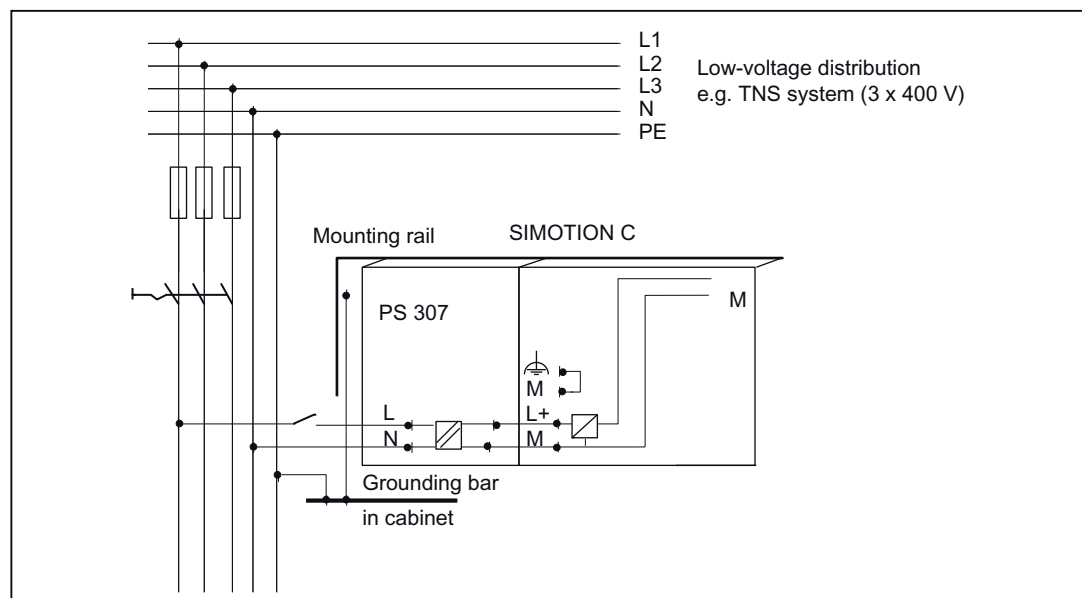

Figure 5-6 Module supply options

Supply system lines

Use flexible cables with a cross-section of 0.25 to 2.5 mm² (or AWG 18 to AWG 14) for wiring the power supply.

If you only use one wire per connection, a ferrule is not required.

You can use ferrules without an insulating collar in accordance with DIN 46228, Form A long version.

Connecting comb

You can also use a connecting comb to connect the PS 307 power supply module to the SIMOTION C. You will find the order numbers of the connecting comb required in chapter Spare parts and accessories (Page 184).

Other 24 V connections

On the PS 307 power supply, there are 24 V connections available via the connecting comb for connecting the supply of the I/O modules.

Wiring with the connecting comb

Proceed as follows to wire the PS 307 power supply module and the SIMOTION C.

! WARNING

You could come into contact with live wires if the power supply module and any additional load power supplies are switched on.

Ensure that the system is de-energized when you wire the system!

1. Open the front doors of the PS 307 and the SIMOTION C.
2. Release the clip for the cable strain relief on the PS 307.
3. Strip the power supply cable (230 V/120 V) (stripped length of 12 mm) and connect it to the PS 307.
4. Tighten the clip for the cable strain relief.
5. Insert the connecting comb and tighten it.
6. Close the front doors

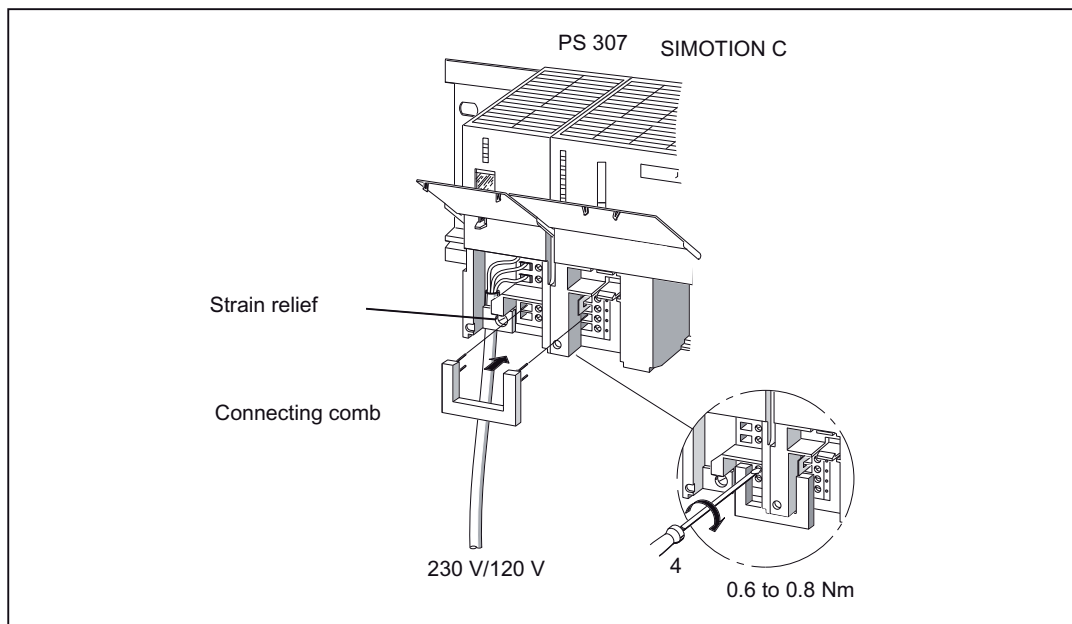

Figure 5-7 Connect power supply module and SIMOTION C with connecting comb

Setting power supply to the required supply voltage

Check whether the supply voltage selection switch is set correctly for your supply voltage. The basic setting on the PS 307 is always 230 V. Proceed as follows to change the setting for the supply voltage:

1. Remove the covering cap using a screwdriver.
2. Set the switch to the available supply voltage.
3. Refit the covering cap over the switch opening.

Reverse polarity protection

If the connection is correct and the power supply is switched on, the "5 VDC" LED is illuminated green.

Note

Your module will not work in the case of reverse polarity. However, a built-in reverse polarity protection will protect the electronics against damage.

Fuse

If a fault is present on the module, a built-in fuse protects the electronics against consequential damage (e.g. fire). In this case, the module must be replaced.

5.1.5 Connecting the drive units

Connecting the connecting cable

Note the following:

Note

Only use shielded, twisted pair cables; the shield must be connected to the metallic or metalized connector housing on the controller side. We recommend that you do not ground the shield on the drive side. This is to separate low-frequency interferences from the analog setpoint signal.

The pre-assembled cable available as an accessory provides the best possible immunity to interference.

Connection of drives (e.g. SIMODRIVE 611 universal with analog setpoint interface) to the onboard drive interface (C230-2, C240)

The figure below shows the connection of the C230-2, C240 to SIMODRIVE 611 universal drive units.

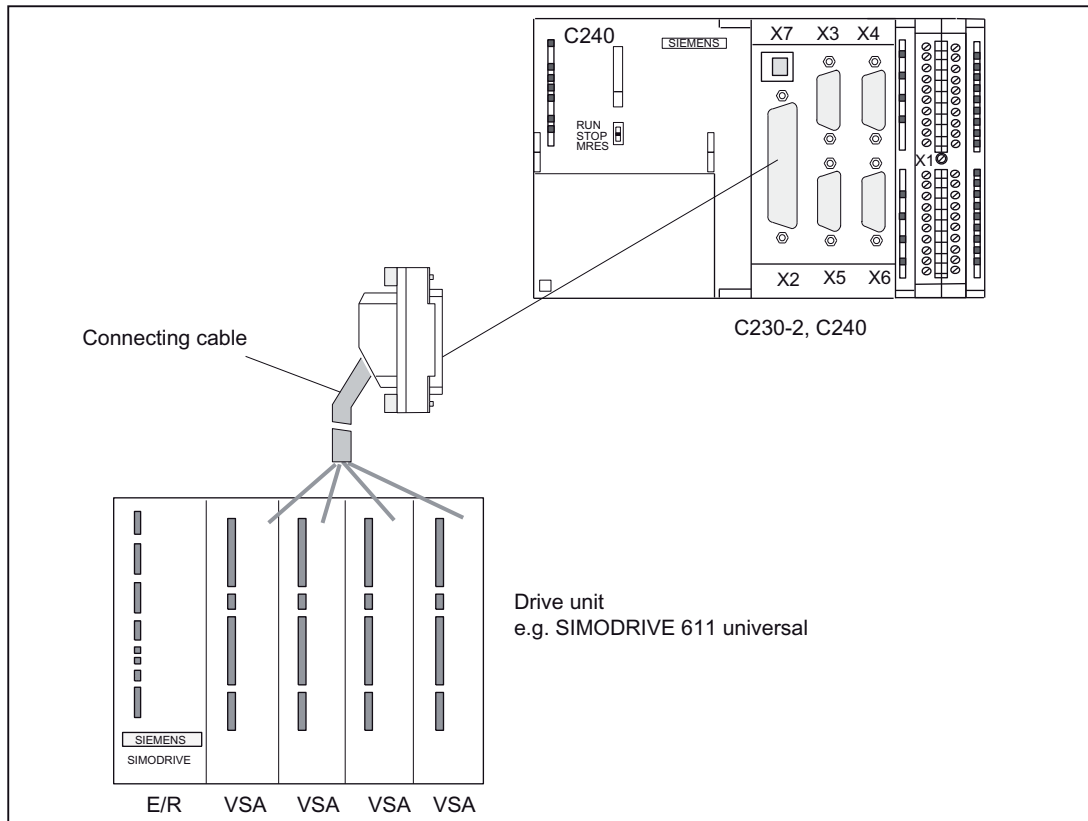

Figure 5-8 Connection of a SIMODRIVE 611 universal drive unit

Procedure:

1. Wire the free cable end of the connecting cable to the terminals on the drive unit. (The terminal markings on the cable ends indicate the corresponding terminals for SIMODRIVE devices.)
2. Open the front cover of the C230-2/C240 and connect the Sub-D socket (50-pin) to the X2 connector.
3. Lock the connector using the finger screws. Close the front cover.

Connecting cable

The connecting cable is a pre-assembled cable for four axes with an analog interface and terminal designation for SIMODRIVE drive units.

The connecting cable is available in a choice of lengths.

See *Catalog PM 21, NC 60, or ST 70*

Wiring diagram

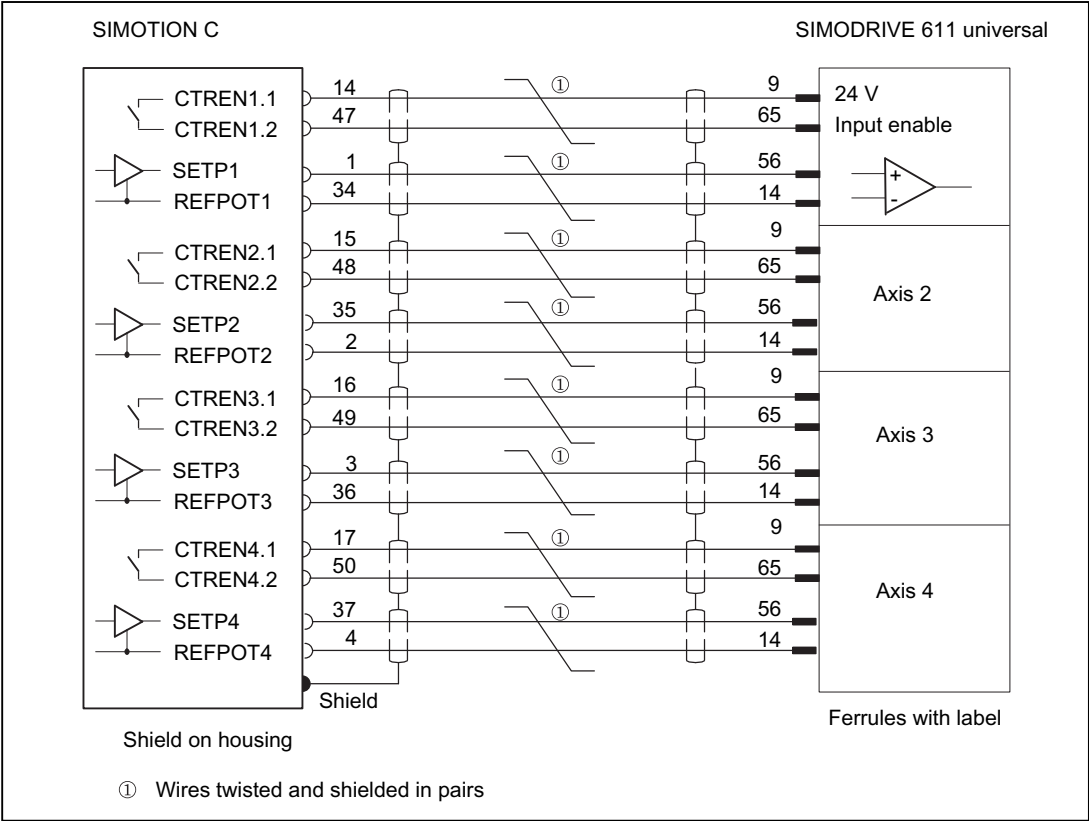

Figure 5-9 Terminal diagram for C230-2/C240 and SIMODRIVE 611 universal with analog setpoint interface

Setpoint assignment

The assignment of the setpoints for axes 1 to 4 is fixed.

Setpoint output signals (X2) for **drives with analog interface**:

- SW1, BS1, RF1.1, RF1.2 for axis 1
- SW2, BS2, RF2.1, RF2.2 for axis 2
- SW3, BS3, RF3.1, RF3.2 for axis 3
- SW4, BS4, RF4.1, RF4.2 for axis 4

Note

When using the drive interface for standard outputs (C240 only), proceed as described in chapter Onboard drive interface (C230-2, C240) (Page 45). Wire the free ends of the connecting cable according to your application.

Connection of stepper drives (e.g. FM STEPDRIVE) to the onboard drive interface (C230-2, C240)

The figure below shows the connection of the C230-2, C240 to FM STEPDRIVE drive units.

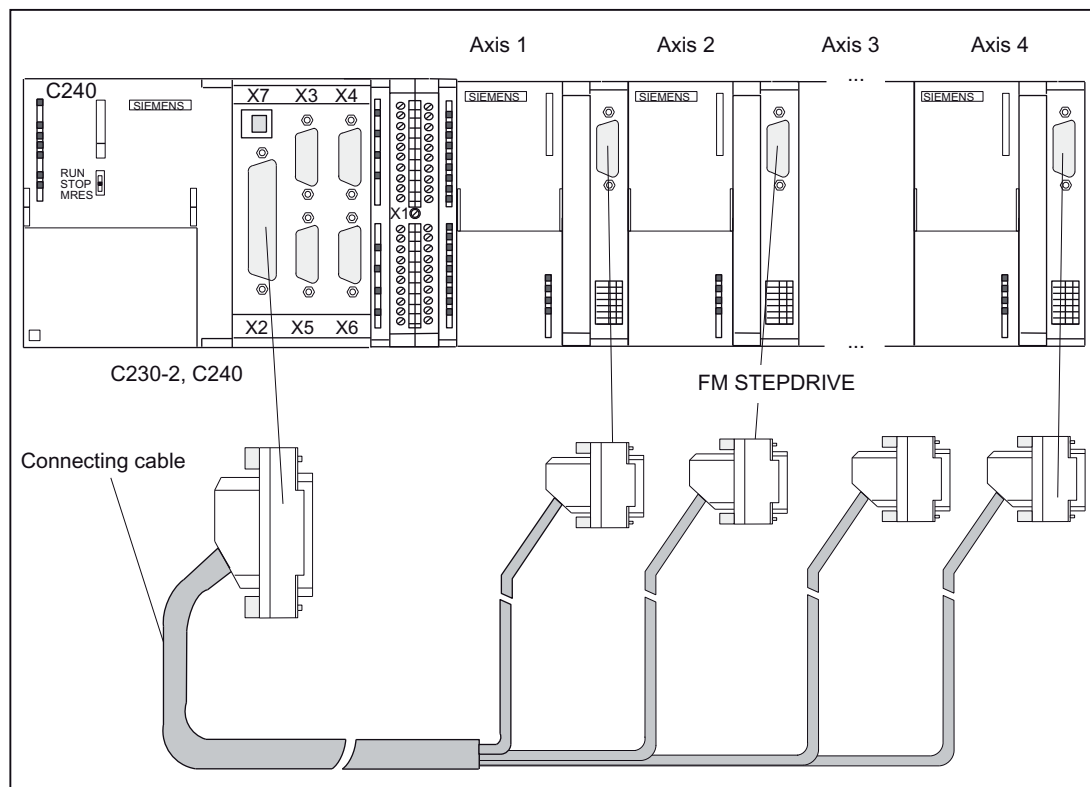

Figure 5-10 Connection of FM STEPDRIVE drive units

Procedure:

1. Insert the Sub-D socket (15-pin) in the FM STEPDRIVE module.
2. Open the front cover of the C230-2/C240 and connect the Sub-D socket (50-pin) to the X2 connector.
3. Lock the connector using the finger screws. Close the front cover.

Connecting cable

The connecting cable is a preassembled cable for four FM STEPDRIVE stepper motor drive units.

See *Catalog PM 21, NC 60.1, or ST 70*

Wiring diagram

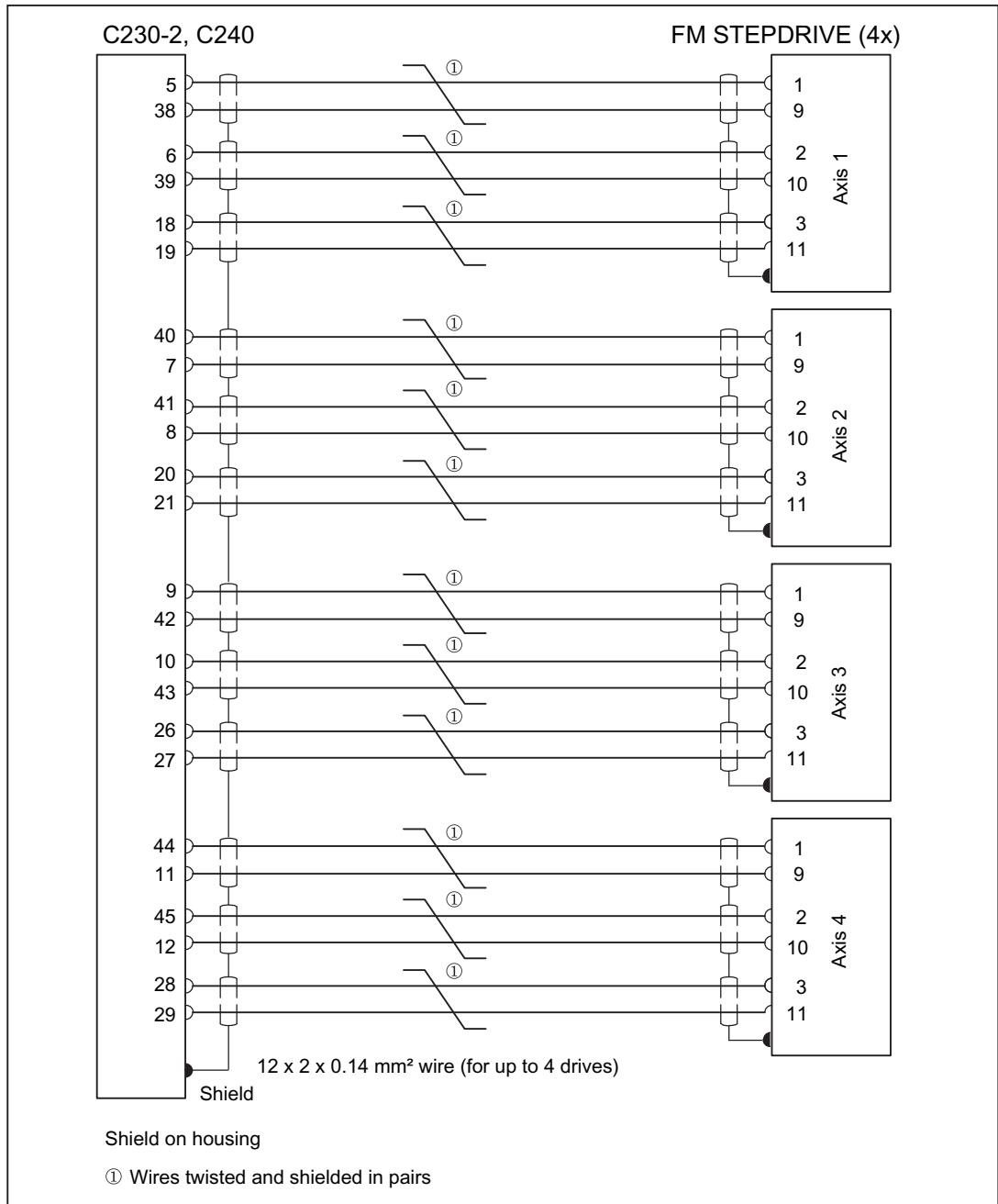

Figure 5-11 Wiring diagram for C230-2/C240 and FM STEPDRIVE

Setpoint assignment

The assignment of the setpoints for axes 1 to 4 is fixed.

Setpoint output signals (X2) for **stepper drive**:

- PULSE1, PULSE1_N, DIR1, DIR1_N, ENABLE1, ENABLE1_N for axis 1
- PULSE2, PULSE2_N, DIR2, DIR2_N, ENABLE2, ENABLE2_N for axis 2
- PULSE3, PULSE3_N, DIR3, DIR3_N, ENABLE3, ENABLE3_N for axis 3
- PULSE4, PULSE4_N, DIR4, DIR4_N, ENABLE4, ENABLE4_N for axis 4

Connection of drives (e.g. SIMODRIVE 611 universal) to the PROFIBUS DP

The figure below shows the connection of the SIMOTION C to a SIMODRIVE 611 universal drive unit.

Note that the "Motion Control with PROFIBUS DP" module must be fitted on the control unit of your drive unit.

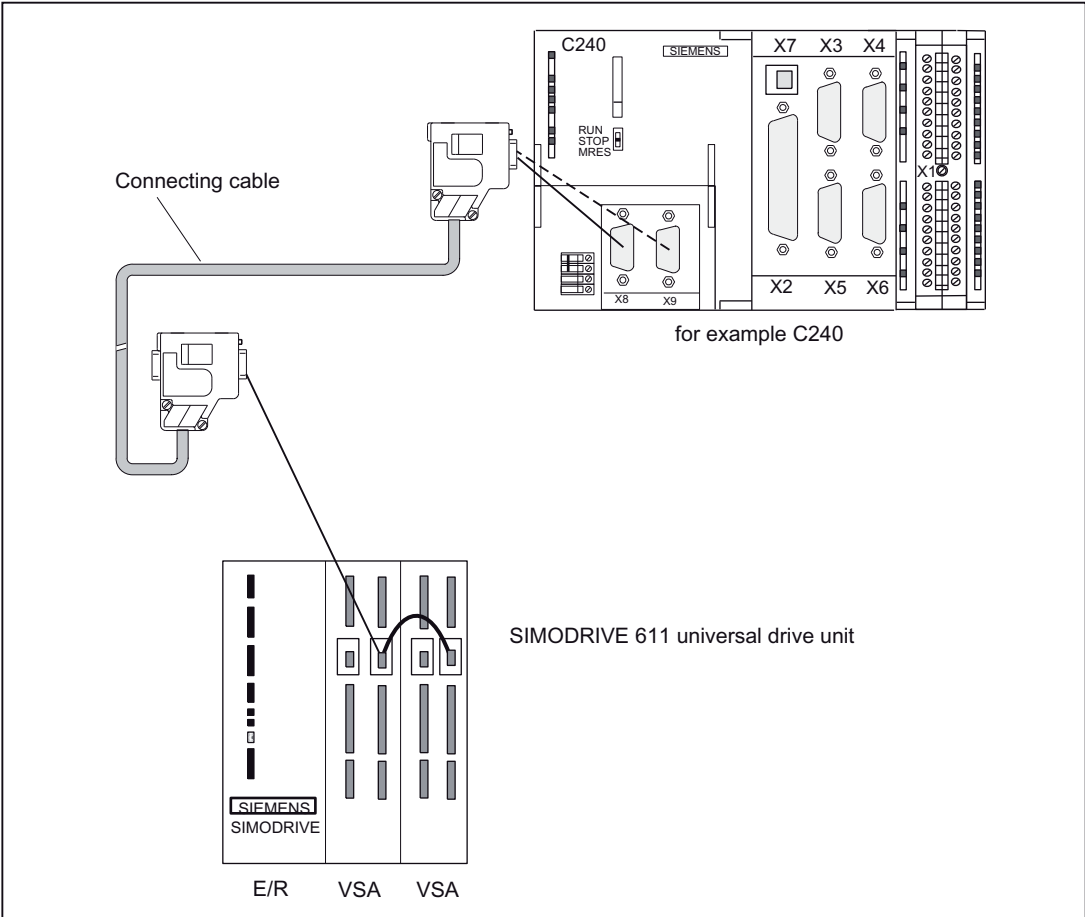

Figure 5-12 Connection of SIMODRIVE 611 universal drive unit to PROFIBUS DP

Procedure:

1. Insert the Sub-D connector (9-pin) into the drive unit.
2. Open the front door of the SIMOTION C and insert the Sub-D connector (9-pin) into the X8/X9 socket.
3. Lock the connector using the finger screws. Close the front cover.

Connecting cable

Details about the bus cable, bus connector and installation can be found in chapter Networking (Page 122).

Note

The maximum cable length is 100 m.

The terminating resistor must be switched in (switch position "On") at the beginning and end of the bus segment. See figure "Bus connector (6ES7 ...): Terminating resistor connected and disconnected" in chapter Network components for a PROFIBUS subnet (Page 125)

Connection of drives (e.g. SINAMICS S120) to PROFINET IO (C240 PN)

The figure below shows the connection of the C240 PN to a SINAMICS S120 drive unit.

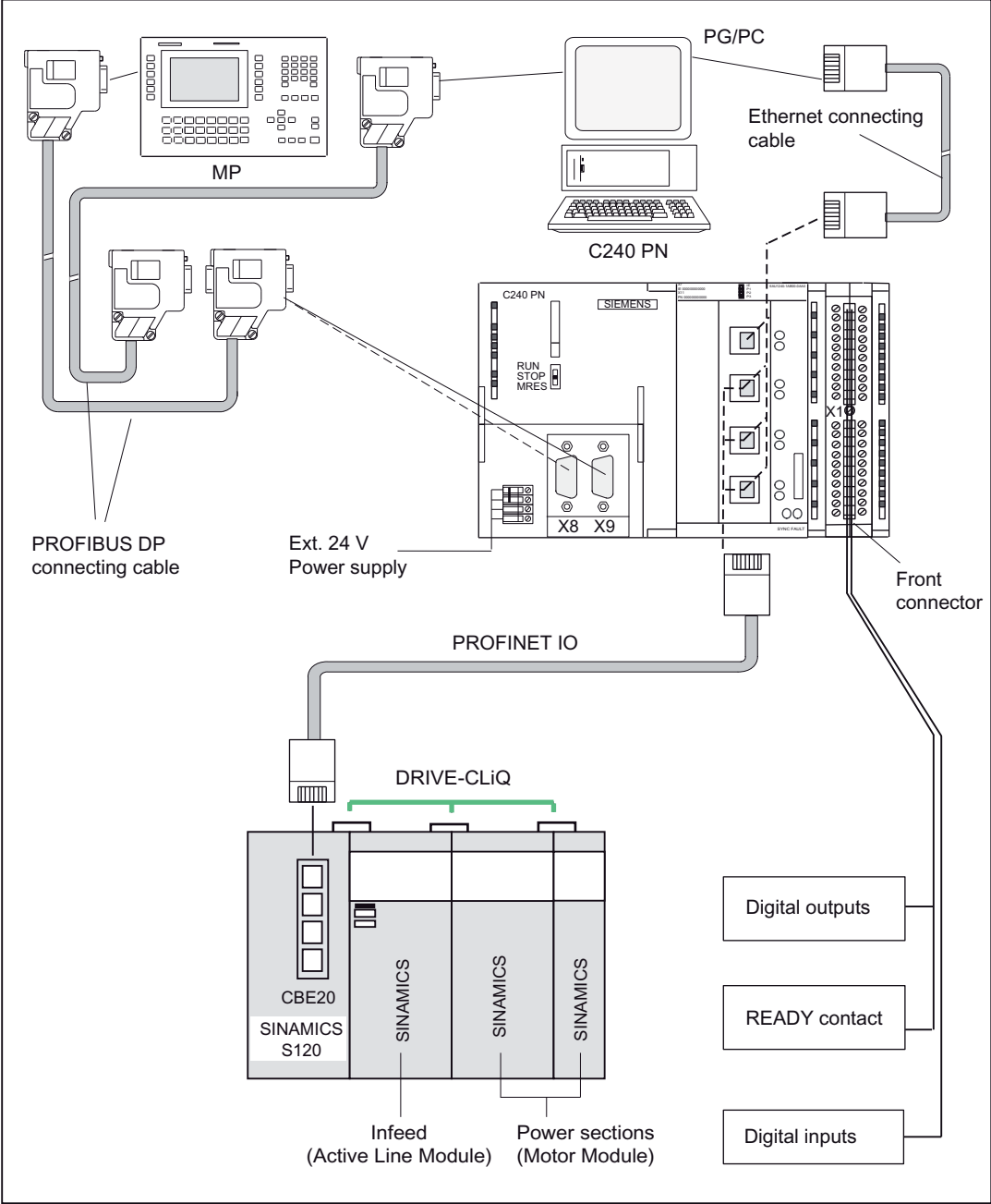

Figure 5-13 Connection of a SINAMICS S120 drive unit on the PROFINET IO

Procedure:

1. Insert the PROFINET connector into the drive unit.
2. Open the front door of the C240 PN and insert the PROFINET connector into the X11 P1, X11 P2 or X11 P3 socket.

Note

The strain relief provided for the PROFINET cable must be used in particular for vibrating machines. The cables should be secured close to the controller to achieve high vibration strength.



Figure 5-14 Strain relief

Connecting cable

Details about the bus cable, bus connector and installation can be found in chapter Networking (Page 122).

Note

The maximum cable length is 100 m.

Mixed operation of analog drives and stepper drives (C230-2, C240)

Connecting cables for your configuration are available on request.

Follow the procedure outlined for connecting analog drives or stepper drives. The design conditions determine whether you install a terminal block or perform the wiring directly with pre-assembled cables.

Note

Ensure that the polarity assignment of the signals is correct. Refer to the technical documentation for your drive unit (e. g. *FM STEPDRIVE, Function Description* manual) and chapter Onboard drive interface (C230-2, C240) (Page 45) of these operating instructions to ensure that the interconnection is correct.

Mixed operation of drives on the onboard drive interface and PROFIBUS DP

Drives with analog and digital connections and stepper drives can be operated together.

Proceed as described for the connection of drives to the onboard drive interface or PROFIBUS DP.

Mixed operation of drives on the onboard drive interface and use as standard output (C240 only)

Follow the procedure outlined for connecting analog drives.

Mixed operation of drives on the PROFIBUS DP and drives on the PROFINET IO (C240 PN)

Drives can be used in mixed operation.

Proceed as described for the connection of drives on the PROFIBUS DP or on the PROFINET IO.

See also

Overview (Page 63)

5.1.6 Connecting the encoders (C230-2, C240)

Connecting the connecting cable

Note the following:

Note

Always use shielded data cables. The shielding must be connected with the metallic or metallized connector housing.

The pre-assembled cable available as an accessory provides the best possible immunity to interference and adequately dimensioned cross-sections for the power supply to the encoders.

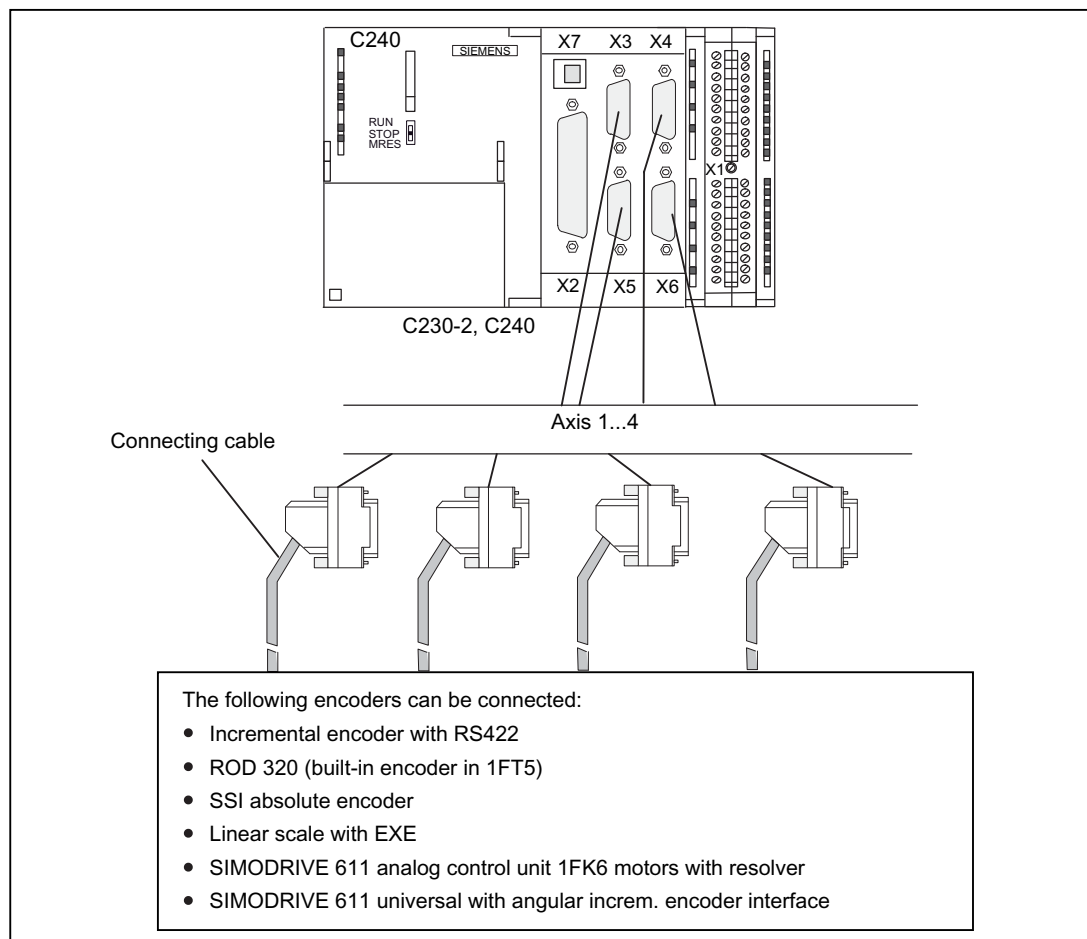

Figure 5-15 Encoder connections

Procedure for connecting encoders

Proceed as follows to connect the encoders:

1. Connect the cable to the encoders.
2. Open the front cover of the C230-2, C240 and insert the Sub-D connectors (15-pin) into sockets X3 to X6.
3. Lock the connector using the finger screws. Close the front cover.

Connecting cables available for encoders

The following connecting cables are available (see figure "Overview of connections"):

- Pre-assembled cable for external encoder or EXEs (for the connection of linear position encoders)
- Pre-assembled cable for built-in encoder with 17-pin round connector
- Pre-assembled cable for absolute encoders (SSI)
- Pre-assembled cable for SIMODRIVE 611 analog closed-loop control module 1FK6 motors with resolver
- Pre-assembled cable for SIMODRIVE 611 universal with incremental shaft encoder interface

The incremental shaft encoder interface is used to emulate an incremental encoder. For this, the actual position value is measured by the encoder connected to the drive unit and transmitted to the C230-2, C240 as an incremental counting pulse.

The encoder supply provided on the C230-2 and C240 is not used. Make sure there is a good ground connection between the controller and drive unit.

The connecting cables are available in a choice of lengths.

See *Catalog PM 21, NC 60, or ST 70*

Actual value assignment

Actual value assignment in the SIMOTION SCOUT axis wizard:

The assignment of actual values is only permanent for position axes with an encoderless stepper motor. The corresponding encoder channel is required for actual value simulation in the hardware.

Example:

For a position axis with an encoderless stepper motor on drive 2, encoder channel 2 is used within the hardware for actual value simulation.

For stepper motors with an encoder or for analog axes, the assignment of encoder channels is subject to no restrictions.

Connection options for encoders on the C230 or C240:

Encoders must be connected to actual value inputs X3 to X6.

The assignment between the drive and encoder channel is subject to no restrictions.

Connection example:

- The encoder for axis 1 is connected to actual value input X3
- The encoder for axis 2 is connected to actual value input X4
- The encoder for axis 3 is connected to actual value input X5
- The encoder for axis 4 is connected to actual value input X6

Note

The assignment between the drive and encoder channel is permanent for position axes with an encoderless stepper motor as a result of the actual value simulation required in the hardware.

5.1.7 Wiring the front connector

The following figure shows how the cables are routed to the front connector and how to suppress line interference through the use of the shield connecting element.

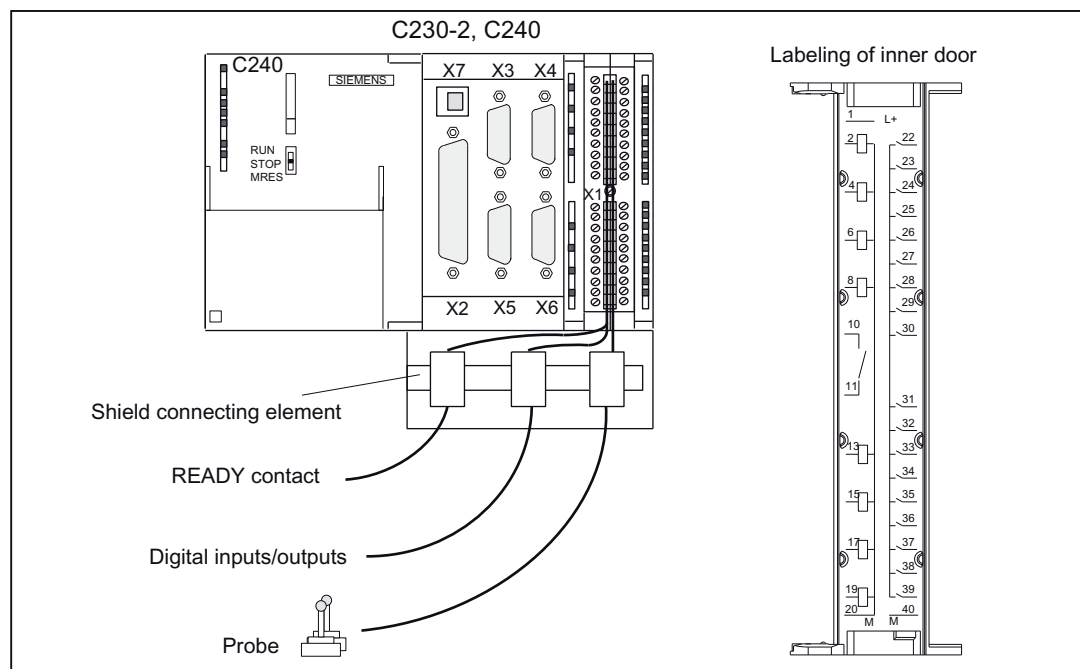

Figure 5-16 Wiring the front connector

Connecting cables

Flexible cable, cross-section 0.25 to 1.5 mm²

Ferrules are not required.

You can use ferrules without an insulating collar in accordance with DIN 46228, Form A long version.

You can connect two cables of 0.25 to 0.75 mm² each in one ferrule.

Note

To achieve optimum interference suppression, a shielded cable must be used for connection of measuring inputs or external zero mark.

Required Tools

3.5-mm screwdriver or power screwdriver

Procedure for front connector wiring

Proceed as follows for the terminal strip:

1. Strip 6 mm of insulation off the cable. It may be necessary to fit a connector sleeve.
2. Open the front cover. Move the front connector into position for wiring.

To do this, push the front connector into the module until it locks into position. In this position the front connector will still protrude from the module.

The connector is locked in position, without electrical contact to the module.

3. If you route the wires out downwards, start the wiring at the bottom. If this is not the case, start at the top. Also screw in terminals that are not assigned.

The tightening torque is 0.4 to 0.7 Nm.

4. Fit the cable strain relief provided around the wiring loom and the front connector.
5. Tighten the strain relief for the cable harness. Push in the strain relief to the left to increase cable space.
6. Tighten the mounting screw to move the front connector into operating position.

Note: When the front connector is moved into operating position, a front connector keying engages in the front connector. The front connector will then fit only this module type.

7. Close the front cover.
8. You can fill out the labeling field provided and insert it in the front cover.

Shielded cables

If a shielded cable is used, the following additional actions are required:

1. Attach the cable shield to a grounded shielding bus immediately after the cable entry point in the cabinet (strip the insulation off the cable for this purpose).

You can use the shield connecting element. This is mounted on the rail and can accommodate up to eight shielding terminals.

2. Continue routing the shielded cable as far as the module but do not make a connection to the shield there.

Shield connecting element

This element can be inserted in the mounting rail to provide screening for shielded cables. It can accommodate up to eight shielding terminals.

See chapter Connecting shielded cables via a shield connecting element (Page 120).

Connection of measuring inputs or proximity sensors (external zero mark)

Procedure:

1. Wire the power supply for the encoders. This must meet the same criteria as the load power supply for the SIMOTION C.
2. Connect the shielded signal line to the encoders.
3. Remove a sufficient length of the cable sheath at the control end so that you can connect the shield to the shield connecting element and the free cable ends to the front connector.
4. Wire the signal line to the front connector.

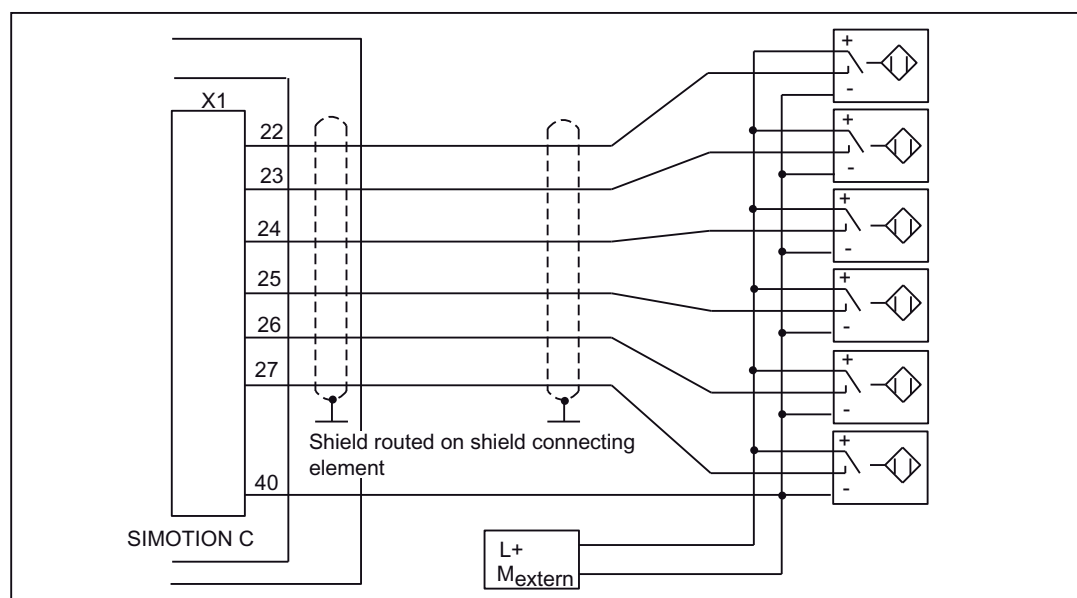

Figure 5-17 Overview of connections for measuring inputs or proximity encoders

Note

For the assignment of the front connector and the description of the I/O interface, refer to chapter I/O interface (Page 68).

Connection of additional actuators/encoders

If you wish to connect additional actuators/encoders to the SMs on the I/O bus, proceed in the same way as for connecting digital inputs/digital outputs to the SIMATIC S7-300.

See the *S7-300, M7-300 Automation Systems, Module Data Manual*.

The digital inputs/digital outputs on the central I/O system are recorded/output at a refresh rate of approx. 1 ms.

5.1.8 Connecting shielded cables via a shield connecting element

Application

With the shield connecting element, you can easily connect all the shielded wires of the SIMOTION C or S7 modules to ground by directly connecting the shield connecting element with the mounting rail.

Design of the shield connecting element

The shield connecting element consists of:

- Retaining bracket with two screw bolts to mount the shield connecting element on the mounting rail (order no.: 6ES5 390-5AA00-0AA0)
- The shielding terminals

You must use the following shielding terminal, depending on the cable cross-section used:

Table 5- 7 Assignment of cable cross-sections and shielding terminals

Wire with shield diameter	Shielding terminal Order no.:
2 cables, each with 2 to 6 mm shield diameter	6ES7 390-5AB00-0AA0
1 cable with 3 to 8 mm shield diameter	6ES7 390-5BA00-0AA0
1 cable with 4 to 13 mm shield diameter	6ES7 390-5CA00-0AA0

The shield connecting element is 80 mm wide and provides space for two rows, each with four shielding terminals.

Fitting the shield connecting element

Fit the shield connecting element as follows:

1. Push the two threaded studs for the retaining bracket into the guide on the underside of the rail. Position the retaining bracket under the modules to be wired.
2. Screw the retaining bracket tight on the mounting rail.
3. The bottom of the shield connection terminal consists of a web interrupted by a slot. Place this part of the shielding terminal on edge a of the retaining bracket (see the following figure). Press the shielding terminals down and pivot them into the required position.

You can fit a maximum of four shield terminals on each of the two rows.

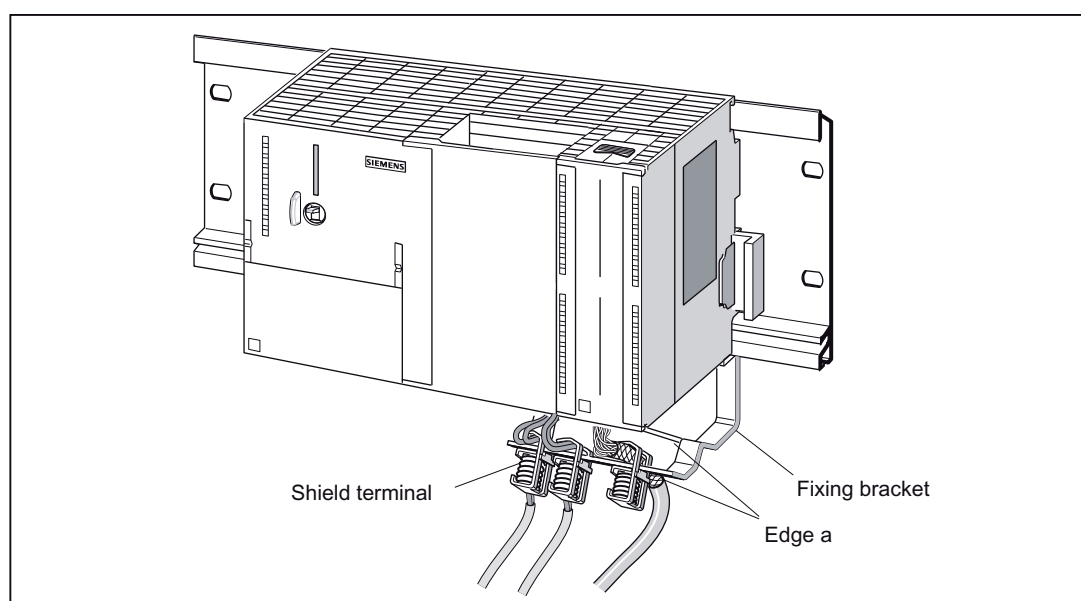

Figure 5-18 Fitting the shield connecting element

Laying the cables

Only one or two shielded cables can be attached per shielding terminal (see table "Assignment of cable cross-sections and shielding terminals"). Attach the cable to the stripped cable shield. The stripped section of cable shield must have a minimum length of 20 mm. If you require more than four shielding terminals, start the wiring on the back row of the shield connecting element.

Tip: Make sure you allow a sufficient length of cable between the shielding terminal and the front connector. This will, for example, ensure that if a repair is required, you can unplug the front connector without also having to remove the shield terminal.

5.2 Networking

5.2.1 Configuring

The *SIMOTION SCOUT* online help shows you how to design and configure a PROFIBUS or Ethernet subnet for your application.

5.2.2 Configuring a PROFIBUS subnet

device = node

Convention: All devices connected in a subnet will be referred to hereafter as nodes.

PROFIBUS addresses

In order for all nodes to communicate with each other, you must assign a 'PROFIBUS-address' to each node **before** connecting them:

You set the PROFIBUS addresses for each node individually using the programming device or PC (also by a switch on the slave for some PROFIBUS DP slaves).

The factory settings on the SIMOTION C are **address 2** and **baud rate 1.5 Mbit/s** for both PROFIBUS DP interfaces X8 and X9.

Tip: Mark the set address on the housing of all nodes in a subnet. You can then always see which address is assigned to which node in your plant.

The "highest PROFIBUS addresses" are preset for each PROFIBUS subnet. You can change these default settings.

Rules for PROFIBUS addresses

Before assigning PROFIBUS addresses, note the following rules:

- All PROFIBUS addresses in a subnet must be unique.
- The highest PROFIBUS address in a subnet must be \geq the largest actual PROFIBUS node address in this subnet.

Recommendation for PROFIBUS addresses

Reserve PROFIBUS address "0" for a service programming device and "1" for a service SIMATIC HMI device, which will be connected to the subnet if required.

Recommendation for the PROFIBUS address of the SIMOTION C in case of replacement or service:

Reserve address "2" for a SIMOTION C. This prevents duplicate addresses when installing a SIMOTION C with factory setting on the subnet (e.g. when a SIMOTION C is replaced). You should therefore assign addresses greater than "2" to additional nodes in the subnet.

Segment

A segment is a bus cable between two terminating resistors. A segment with SIMOTION C as the master can contain up to 64 slaves. In addition, a segment is limited by the permitted cable length according to the baud rate (see chapter Onboard measuring system interface (C230-2, C240) (Page 52)).

Rules for connecting nodes in a subnet

- Connect all nodes in a subnet "in series". In addition, integrate the programming devices and SIMATIC HMI devices for commissioning or servicing in the subnet in series.
- If you are operating more than 32 nodes in one subnet, you must use RS 485 repeaters to connect the bus segments (see also the description of the RS 485 repeater in the *S7-300 Automation Systems, M7-300, Module Data Manual*).
In a PROFIBUS subnet, all bus segments combined must have at least one DP master and one DP slave.
- Use RS 485 repeaters to connect ungrounded bus segments and grounded bus segments.
- The maximum number of nodes per bus segment decreases with each RS 485 repeater. That is, if a bus segment contains one RS 485 repeater, the bus segment can contain no more than 31 additional nodes. However, the number of RS 485 repeaters does not affect the maximum number of nodes on the bus.
Up to ten segments can be connected in series.
- Switch on the terminating resistor at the first and last node of a segment.

Components

Connect the individual nodes using bus connectors and the PROFIBUS cable, also refer to chapter Network components for a PROFIBUS subnet (Page 125). Remember to provide a bus connector with a programming device socket at the ends of the subnet. This will give you the option of expanding the subnet if required (for example, for a programming device or SIMATIC HMI device).

Use RS 485 repeaters for the connection between segments and for extending the cable.

Terminating resistor

A cable must be terminated with its own surge impedance to prevent line disturbances caused by reflections. To this end, activate the terminating resistor at the first and last node of a subnet or segment (see figure "Bus connector (6ES7...): Terminating resistor connected and disconnected" in chapter Network components for a PROFIBUS subnet (Page 125)

Make sure that the nodes to which the terminating resistor is connected are always supplied with voltage during power-up and operation.

Example

The following figure shows an example configuration of a subnet with SIMOTION C.

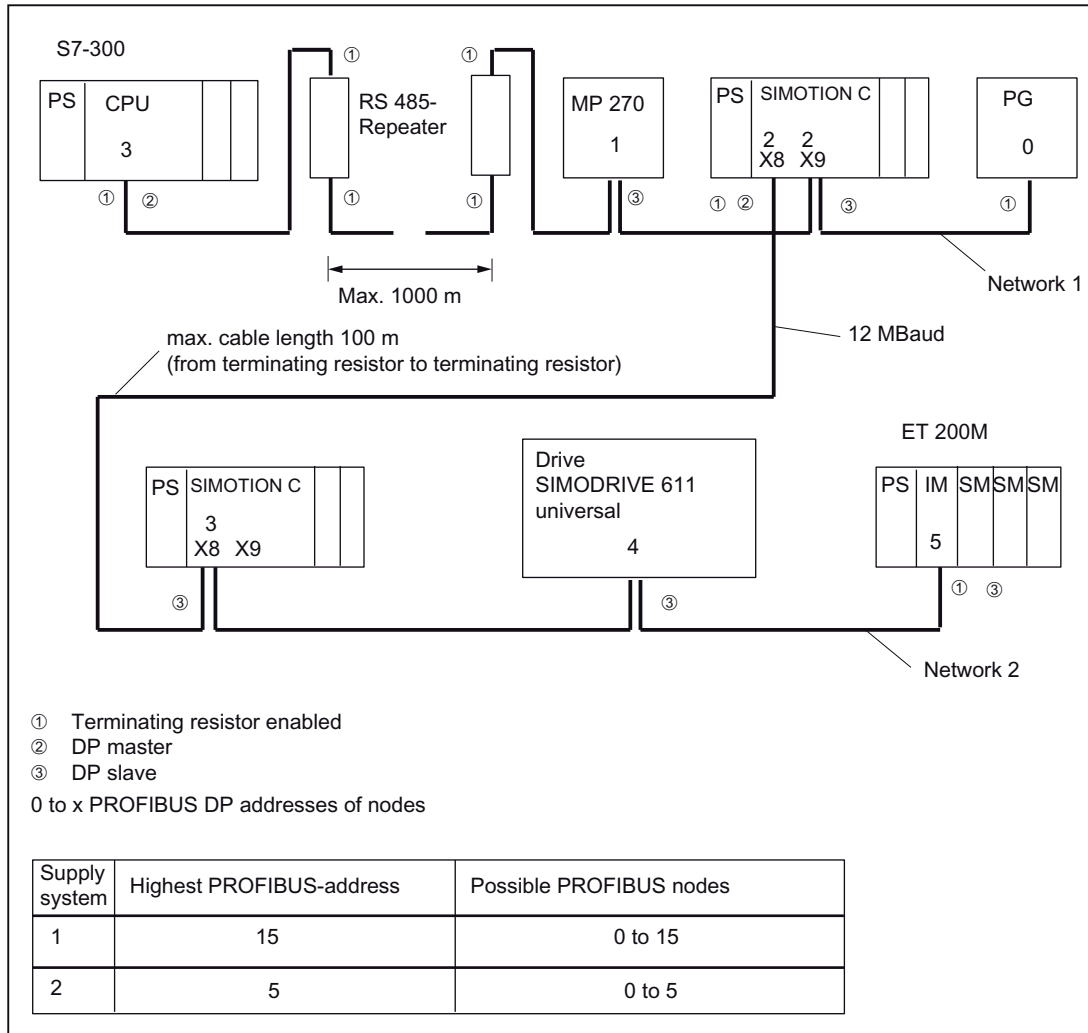

Figure 5-19 Networking example

Segment in subnet

The baud rate determines the cable length of a subnet segment (see the following table).

Table 5- 8 Permitted cable lengths of a subnet segment for specific baud rates

Baud rate	Max. cable length of a segment (in m)
9.6 to 187.5 bits/s	1000 ¹⁾
500 Kbits/s	400
1.5 Mbit/s	200
3 to 12 Mbits/s	100

¹⁾ With isolated interface

Greater cable lengths

You need to install RS485 repeaters for segments requiring cable lengths longer than the allowed length. The maximum possible cable length between two RS 485 repeaters corresponds to the cable length of a segment (see the previous table). You can connect up to nine RS 485 repeaters in series.

Note that an RS 485 repeater must be counted as a subnet node when determining the total number of nodes to be connected. This is true even if the RS 485 repeater is not assigned its own PROFIBUS address.

5.2.3 Network components for a PROFIBUS subnet

PROFIBUS cable

We can offer you e.g. the following PROFIBUS cables:

Table 5- 9 PROFIBUS cable

Cables	Order no.
PROFIBUS cable	6XV1 830-0EH10
PROFIBUS direct-buried cable	6XV1 830-3FH10
PROFIBUS drum cable	6XV1 830-3EH10

Properties of the PROFIBUS cable

The PROFIBUS cable is a two-core, twisted, and shielded cable with the following features:

Table 5- 10 Properties of the PROFIBUS cable

Features	Values
Characteristic impedance	Approx. 135 to 160 Ω (f = 3 to 20 MHz)
Loop resistance	$\leq 115 \Omega/\text{km}$
Effective capacitance	30 nF/km
Damping	0.9 dB/100 m (f = 200 kHz)
Permissible conductor cross-section	0.3 mm ² to 0.5 mm ²
Permitted cable diameter	8 mm \pm 0.5 mm

Rules for laying

PROFIBUS cables must not be twisted, stretched, or compressed.

When installing the indoor bus cable, you should also remember the following boundary conditions (d_A = outer diameter of the cable):

Table 5- 11 Boundary conditions for indoor routing of bus cable

Features	Limitations/constraints
Bending radius for a single bend	$\geq 80 \text{ mm } (10 \times d_A)$
Bend radius for multiple bends	$\geq 160 \text{ mm } (20 \times d_A)$
Permissible temperature range for installation	- 40° C to + 60° C
Shelf and static operating temperature range	- 40° C to + 60° C

Bus connector

The bus connector is used to connect the PROFIBUS cable to the PROFIBUS DP interfaces (X8, X9), thus establishing a connection to additional nodes.

The following bus connectors are available:

- Up to 12 Mbits/s, cable outlet 90°
 - Without PG socket (6ES7 972-0BA12-0XA0 or 6ES7 972-0BA50-0XA0)
 - With PG socket (6ES7 972-0BB12-0XA0 or 6ES7 972-0BB50-0XA0)
- Up to 12 Mbits/s, canted cable turn
 - Without PG socket (6ES7 972-0BA41-0XA0)
 - With PG socket (6ES7 972-0BB41-0XA0)

Inserting a bus connector in a module

Proceed as follows to connect the bus connector:

1. Plug the bus connector into the module.
2. Screw the bus connector tightly onto the module.
3. If the bus connector is located at the start or the end of a segment, you must connect the terminating resistor ("ON" switch setting) (refer to the following figure).

Make sure that the nodes at which the terminating resistor is located are always supplied with voltage during startup and operation.

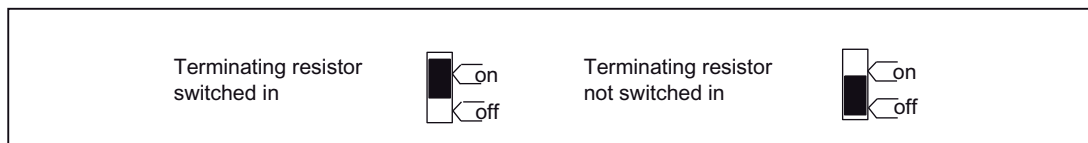



Figure 5-20 Bus connector (6ES7 ...): terminating resistor switched on and off

Unplugging a bus connector

You can unplug a bus connector with a looped-through bus cable at any time from the PROFIBUS DP interface without interrupting data exchange on the bus.

 WARNING
Data traffic error might occur on the bus!
A bus segment must always be terminated at both ends with the terminating resistor. This is not the case if the last bus connector node is de-energized, for example. Because the bus connector takes its voltage from the station, this terminating resistor is ineffective.
Please make sure that power is always supplied to stations on which the terminating resistor is active.

5.2.4 Configuring an Ethernet subnet on the Ethernet interface

Overview

You can connect an Industrial Ethernet to the 8-pin RJ45 **X7** socket, see Figure "Overview of the cable connecting the SIMOTION C to the servo drive (digital connection) - example" in chapter Overview of wiring diagram (Page 94).

Industrial Ethernet is a communication network with a transmission rate of 10/100 Mbits/s.

Communication between SIMOTION C, the PG/PC (e.g. STEP 7, SIMOTION SCOUT, SIMATIC NET OPC), and the I/O devices provided for this purpose is supported by the Ethernet.

A shielded twisted pair cable is used for the networking in this case. For additional information, refer to the *SIMATIC NET, Industrial Twisted Pair and Fiber Optic Networks Manual*. This document is supplied in electronic format with SIMOTION SCOUT.

The following connecting cables are recommended:

- SIMATIC NET, Ind. Ethernet TP XP CORD RJ45/RJ45, TP cable assembled with 2 RJ45 plugs, send and receive cables crossed
Order no.: 6XV1870-3R□□□ (□□□ - length code)
- SIMATIC NET, Ind. Ethernet TP CORD RJ45/RJ45, TP cable assembled with 2 RJ45 plugs
Order no.: 6XV1870-3Q□□□ (□□□ - length code)

You can obtain additional information about the different cable systems for Ethernet from your SIEMENS contact.

Note

A crossover cable should be used for the direct connection of the controller to a PG/PC.

Loading the Ethernet configuration via PROFIBUS DP (loading of the IP address)

For configuration using Industrial Ethernet, the SIMOTION C must be provided with an IP address, the subnet mask and the router address.

To configure the Ethernet addresses and transfer them to the SIMOTION C, proceed as follows:

1. Open your project.
2. Open HW Config. Double-click the SIMOTION C module to open the "Properties - C2xx" dialog box.
3. On the "General" tab, click the "Properties" button of the Ethernet interface. The "Properties - C2xx Ethernet Interface" dialog is displayed.
4. In this dialog, click "New". The "New Industrial Ethernet" subnet dialog is displayed. In this dialog box, you can change the name of the new subnet or confirm the factory setting with "OK".
5. The newly created Ethernet subnet is now shown under Subnet in the "Properties - C2xx Ethernet Interface" dialog and must be selected.
6. In this dialog box, enter the required addresses for IP address and subnet dialog box. Under Router, choose whether a router is to be used. If using a router, enter the router address.
7. Confirm this dialog box with "OK".
8. Close the "Properties - C2xx" dialog with "OK".
9. Save and compile the modified hardware configuration.
10. Load the new hardware configuration to the SIMOTION C via PROFIBUS DP.

Loading the Ethernet configuration via Ethernet (loading of the IP address)

If a PROFIBUS DP is not available for the initial loading of the IP address, the following procedure starting from Windows 2000 can be used: The "Automatically Assign IP Address" setting must be enabled in the TCP/IP configuration of the PC.

1. Connecting a Windows PC and C2xx directly via RJ45 crossover cable.
2. Boot the Windows PC. The PC does not find a DHCP server and automatically selects an IP address from the APIPA subnet (Automatic Private IP Addressing) 169.254.0.0.
3. Load the new hardware configuration with the new IP address via Ethernet to IP address 169.254.11.22 (default IP address for the C2xx upon delivery).

Note

You can also write the user project and/or configuration with SIMOTION SCOUT and the menu command "Load to file system" directly from the PC to the memory card (micro memory card). To do this, select the device in the project navigator and execute the "Load to file system" command in the context menu.

5.2.5 Configuring an Ethernet subnet on the PROFINET interface (C240 PN)

Overview

You can connect a PROFINET node to the 8-pin RJ45 X11 P1, X11 P2 and X11 P3 sockets, see Figure "Overview of the cable connecting the C240 PN to the servo drive (digital connection) - example" in chapter Overview of wiring diagram (Page 94).

PROFINET is a communication network with a transmission rate of 100 Mbit/s.

You can use a PG/PC to communicate with STEP 7, SIMOTION SCOUT, and SIMATIC NET OPC.

A shielded twisted pair cable is used for the networking in this case. For additional information, refer to the *SIMATIC NET, Industrial Twisted Pair and Fiber Optic Networks Manual*. This document is supplied in electronic format with SIMOTION SCOUT.

All ports of the PROFINET interface support auto-MDI(X) in contrast to the Ethernet interface. A crossover cable is therefore not required for a direct connection to the PG/PC.

The following connecting cables are recommended:

- SIMATIC NET, Ind. Ethernet FC TP standard cable GP
Order no.: 6XV1840-2AH10 (sold by the meter)
- SIMATIC NET, Ind. Ethernet FC TP trailing cable GP
Order no.: 6XV1870-2D (sold by the meter)
- SIMATIC NET, Ind. Ethernet TP XP CORD RJ45/RJ45, TP cable assembled with two RJ45 plugs, send and receive cables crossed
Order no.: 6XV1870-3R□□□ (□□□ - length code)
- SIMATIC NET, Ind. Ethernet TP CORD RJ45/RJ45, TP cable assembled with two RJ45 plugs
Order no.: 6XV1870-3Q□□□ (□□□ - length code)

The following bus connectors can be used with the C240 PN:

- SIMATIC NET, Ind. Ethernet FC RJ45 plug 145
Order no.: 6GK1901-1BB30-0AA0 (1 item)
Order no.: 6GK1901-1BB30-0AB0 (10 items)

You can obtain additional information about the different cable systems for PROFINET and Ethernet from your SIEMENS contact.

Loading the PROFINET configuration via PROFIBUS DP (loading of the IP address)

For configuration using PROFINET, the SIMOTION C must be provided with an IP address, the subnet mask and the router address.

To configure and transfer PROFINET addresses to the C240 PN, proceed as follows:

1. Open your project.
2. Open HW Config. Double-click the X11 "PNxIO" slot of the C240 PN module to open the "Properties - PNxIO" dialog box.
3. Click the "Properties" button of the Ethernet interface. The "Properties - PNxIO Ethernet Interface" dialog box is displayed.
4. In this dialog, click "New". The "New Industrial Ethernet" subnet dialog is displayed. In this dialog box, you can change the name of the new subnet or confirm the factory setting with "OK".
5. The newly created Ethernet subnet is now shown under Subnet in the "Properties - Ethernet Interface" dialog box and must be selected.
6. In this dialog box, enter the required addresses for IP address and subnet dialog box. Under Router, choose whether a router is to be used. If using a router, enter the router address.
7. Confirm this dialog box with "OK".
8. Close the "Properties - PNxIO" dialog box with "OK".
9. Save and compile the modified hardware configuration.
10. Load the new hardware configuration to the C240 PN via PROFIBUS DP.

Loading the PROFINET configuration via Ethernet (loading of the IP address)

If a PROFIBUS DP is not available for the initial loading of the IP address, the following procedure starting from Windows 2000 can be used: The "Automatically Assign IP Address" setting must be enabled in the TCP/IP configuration of the PC.

1. Connecting a Windows PC and C240 PN directly via RJ45 crossover cable
2. Boot the Windows PC. The PC does not find a DHCP server and automatically selects an IP address from the APIPA subnet (Automatic Private IP Addressing) 169.254.0.0.
3. Load the new hardware configuration with the new IP address via Ethernet to IP address 169.254.11.22 (default IP address of the SIMOTION C as delivered)

Note

You can also write the user project and/or configuration with SIMOTION SCOUT and the menu command "Load to file system" directly from the PC to the memory card (micro memory card). To do this, select the device in the project navigator and execute the "Load to file system" command in the context menu.

5.2.6 Factory setting

After resetting the SIMOTION C to the factory setting (see chapter Setting SIMOTION C to factory settings (Page 158)) or when the module is delivered, the following addresses are set:

- Baud rate = 1.5 Mbit/s
- PROFIBUS address for the interfaces X8 = 2 and X9 = 2
- Ethernet interface:
 - IP address = 169.254.11.22
 - Subnet mask = 255.255.0.0
 - Router address = do not use a router
- PROFINET interface X11 (C240 PN)
 - IP address = no valid address
 - Subnet mask = no valid address
 - Router: Do not use a router

5.2.7 MPI subnet

An MPI subnet has the same basic configuration as a PROFIBUS subnet. The installation rules, stated in the chapter Configuring a PROFIBUS subnet (Page 122), therefore apply.

Addressing

6.1 Slot-oriented address allocation for modules (default addresses for centralized I/O)

Introduction

In the case of addressing based on the slot (default addressing), a module start address is assigned to every slot number. Depending on the type of module, these are different addresses for digital, analog, FM and CP modules (see table below). In this section we will show you which module start address is assigned to which slot number. You need this information to determine the module start addresses of the modules used.

Maximum configuration

The following figure shows a configuration of a rack and the possible slots. A 2-tier layout with IM 365 is possible with SIMOTION C.

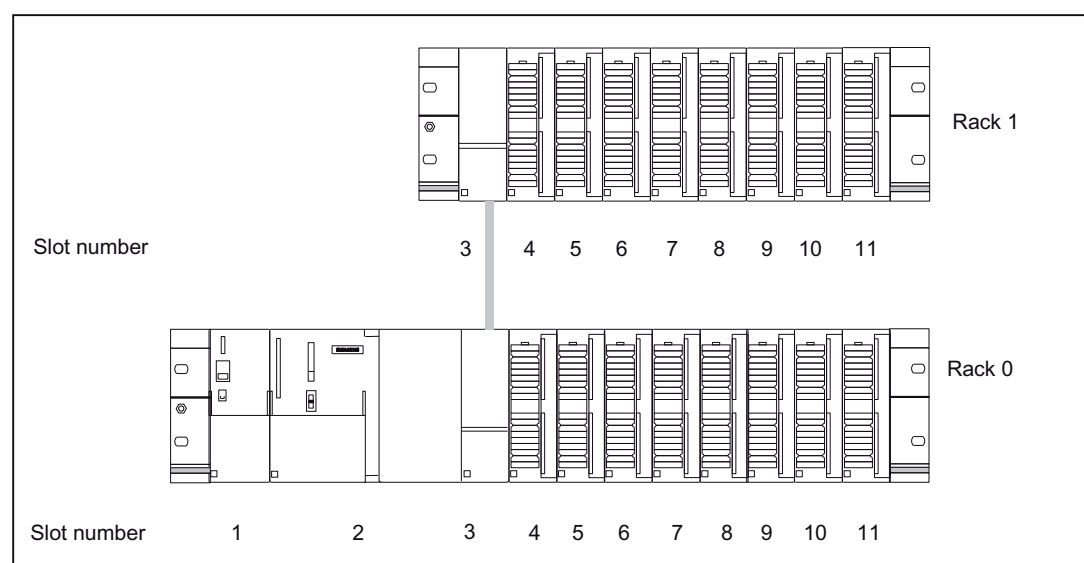

Figure 6-1 Slots for modules on rack (centralized I/O)

Module start addresses

The following table shows the assignment of module start addresses to slot numbers and racks.

In the case of input/output modules, the input addresses and output addresses start from the same module start address.

Table 6- 1 Module start addresses of signal modules

Module carrier	Module start addresses	Slot number										
		1	2	3	4	5	6	7	8	9	10	11
0	Digital	PS	SIMOTION C	IM 365 S	0	4	8	12	16	20	24	28
	Analog ¹⁾				256	272	288	304	320	336	352	368
1	Digital	-	-	IM 365 R	32	36	40	44	48	52	56	60
	Analog ¹⁾				384	400	416	432	448	464	480	496

¹⁾ The FM and CP modules are assigned to the analog address range.

Note

Do not insert any non-configured modules centrally. Modules that are installed but not configured are repeatedly addressed via the I/O bus. This requires additional computing time.

6.2 User-assignable addressing on the SIMOTION C (centralized and distributed I/O)

User-assignable addressing

User-assignable addressing means you can assign an address of your choice to each module or slot, for example, integrated inputs/outputs, drives. You make this assignment in the **hardware configuration** (see *SIMOTION SCOUT* online help). Here you specify the module start address on which all further module addresses will then be based.

advantages

Advantages of user-definable addressing:

- You can make the best possible use of the available address spaces because there are no "address gaps" between the modules.
- When creating standard software, you can specify addresses which are independent of the respective configuration of the SIMOTION modules.

6.3 Addressing signal modules

Introduction

The following section describes signal module addressing in the default setting. You need the information so that you can address the signal module channels in the user program.

Addresses of digital modules

The address of an input or output of a digital module is made up of the byte address and the bit address.

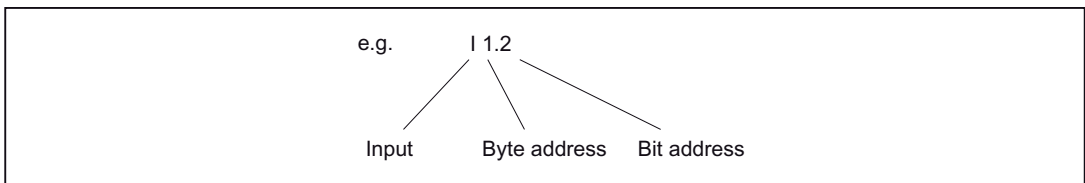

Figure 6-2 Address of an input of a digital module - example

The byte address is governed by the module start address.

You can note the bit address on the module.

The figure below shows you the scheme by which the addresses of the individual channels of the digital module are obtained.

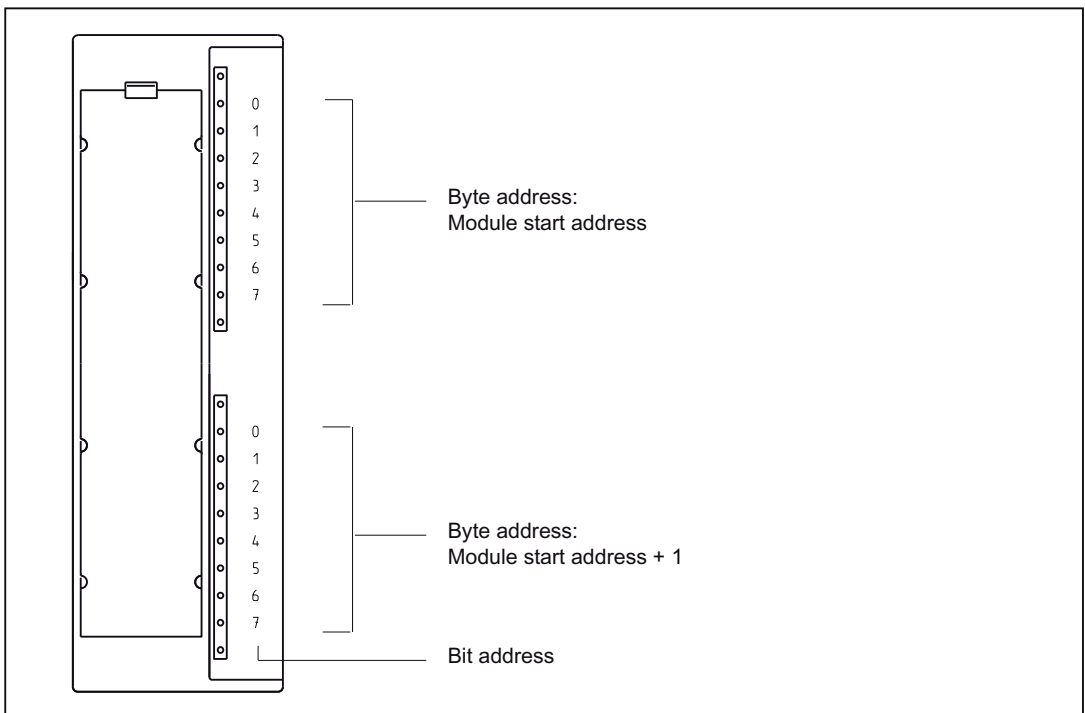

Figure 6-3 Addresses for the inputs and outputs of digital modules

Example of digital modules

The example in the figure below shows which default addresses are derived when a digital module is located in slot 4 (that is, when the module start address is 0).

Slot number 3 is reserved as no interconnection module is present in the example.

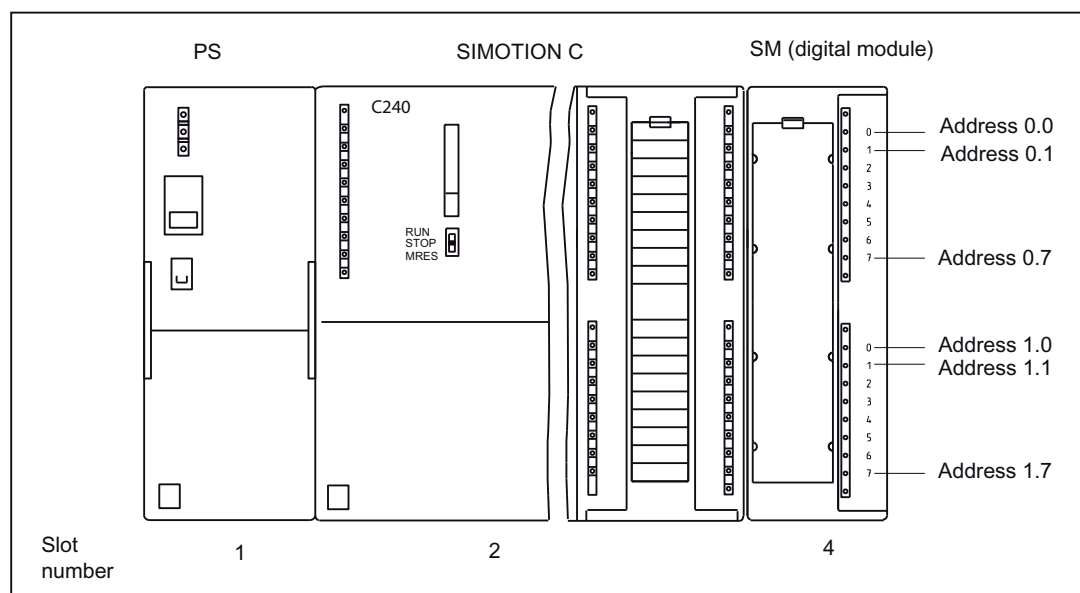

Figure 6-4 Addresses for the inputs and outputs of the digital module in slot 4

Addresses of analog modules

The address of an analog input or analog output channel is always an even address.

The channel address is based on the module start address.

If the first analog module is in slot 4, then it has the default start address 256. The start address of each additional analog module is raised per slot by 16 (see table "Slots for modules on rack (centralized I/O)").

An analog input/analog output module has the same start addresses for the analog input and analog output channels.

Example for analog modules

The example in the figure below shows you which default channel addresses are obtained for an analog module located at slot 4. You will see that in the case of an analog input/analog output module, the analog input and analog output channels are addressed from the same address, the module start address.

Slot number 3 is reserved as no interconnection module is present in the example.

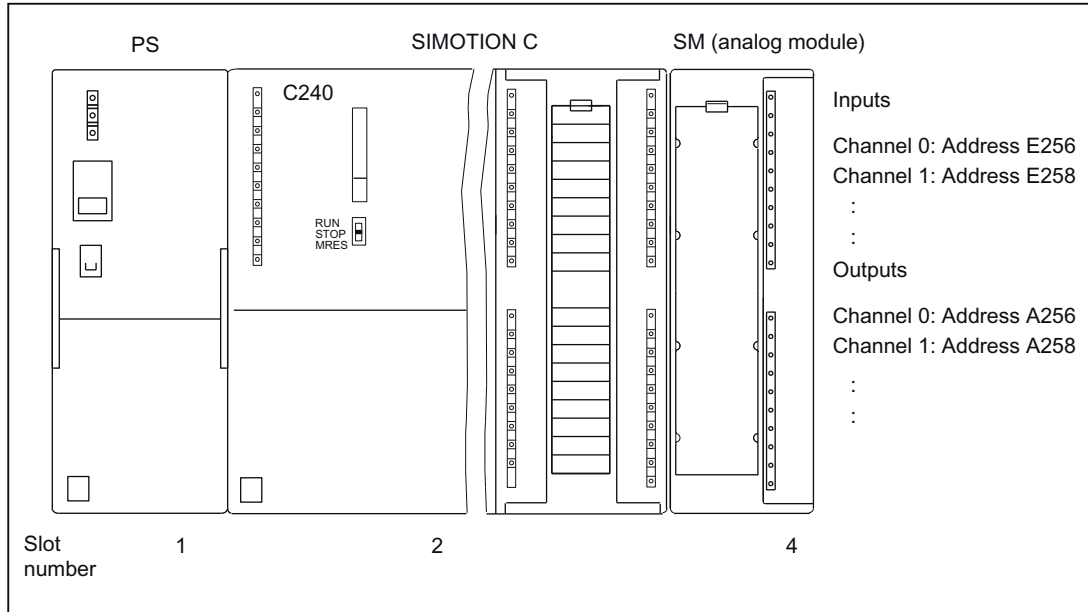

Figure 6-5 Addresses for the inputs and outputs of the analog module in slot 4

Addresses of the FM and CP modules

The FM and CP modules are assigned to the analog address range. In addition, the FM and CP modules have extended interfaces (data sets). For a detailed description, see the corresponding module's manual.

6.4 Addressing the onboard digital inputs and outputs of the SIMOTION C

The following figure shows the default start addresses of the onboard digital inputs/outputs.

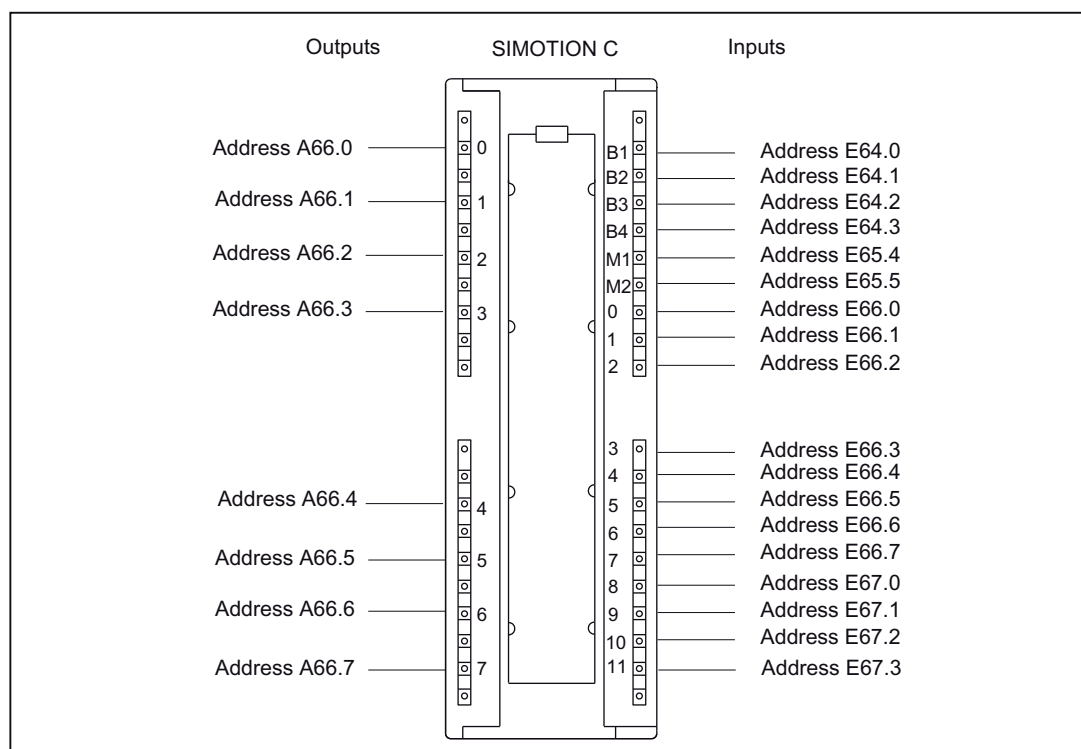

Figure 6-6 Addressing the onboard digital inputs/outputs

Note

These addresses can be modified by the user in the *hardware configuration* (see **SIMOTION SCOUT** online help).

When used by a TO (e.g. measuring input/output cam), the address must be ≥ 64 .

All start addresses/signal bits (64.4...64.7, 65.0...65.3, 65.6, 65.7, 67.4...67.7) not listed do not have any defined values and consequently may not be used for evaluation.

As of SIMOTION V4.2, the onboard digital inputs/outputs of the C240 and C240 PN cannot only be interconnected with variables via their direct addresses, but also by means of symbolic assignment.

6.5 Addressing the onboard drive and measuring system interface of the C230-2, C240

Use as a standard output is only possible by means of an I/O variable. The I/O variables must be created on the addresses of the corresponding axis channel specified via the **hardware configuration** (relating to the default start address).

Symbolic assignment is not available for this application.

The following figure shows the default start addresses of the onboard drive interface of the C230-2/C240.

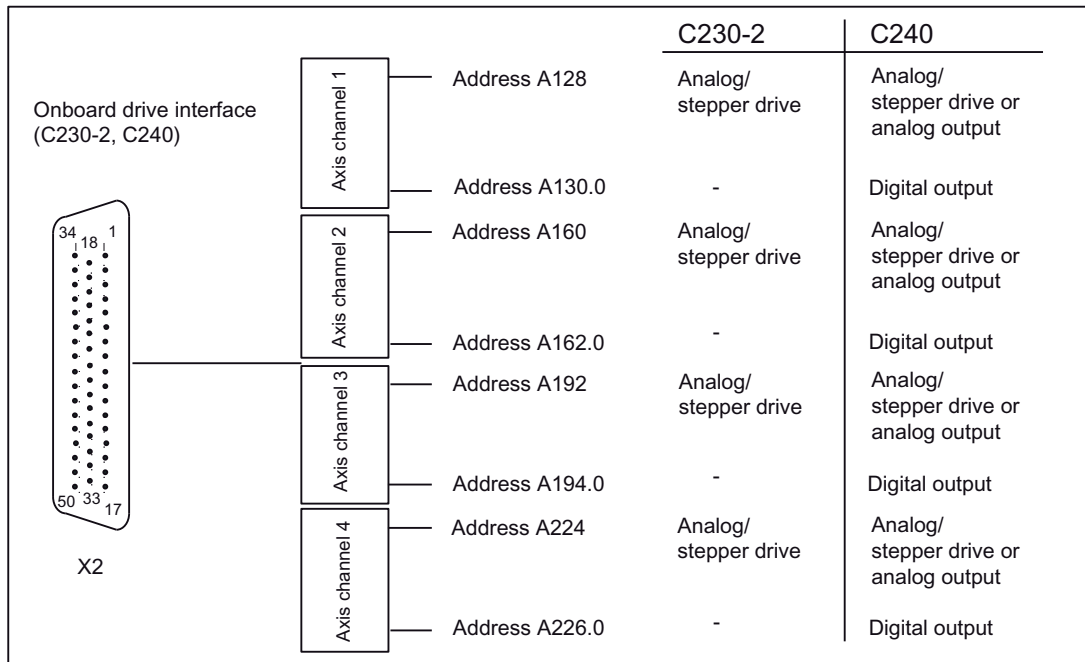

Figure 6-7 Addressing the onboard drive interface

An available encoder input of an axis channel (e.g. for a speed-controlled axis) can be used as an input for a 16-bit up/down counter (90-degree pulse train of a connected TTL encoder, zero pulse not required). The counter value can be accessed by means of an I/O variable (default start address of the axis channel). Symbolic assignment is not available for this application.

6.5 Addressing the onboard drive and measuring system interface of the C230-2, C240

The following figure shows the default start addresses of the onboard measuring system interface of the C230-2/C240.

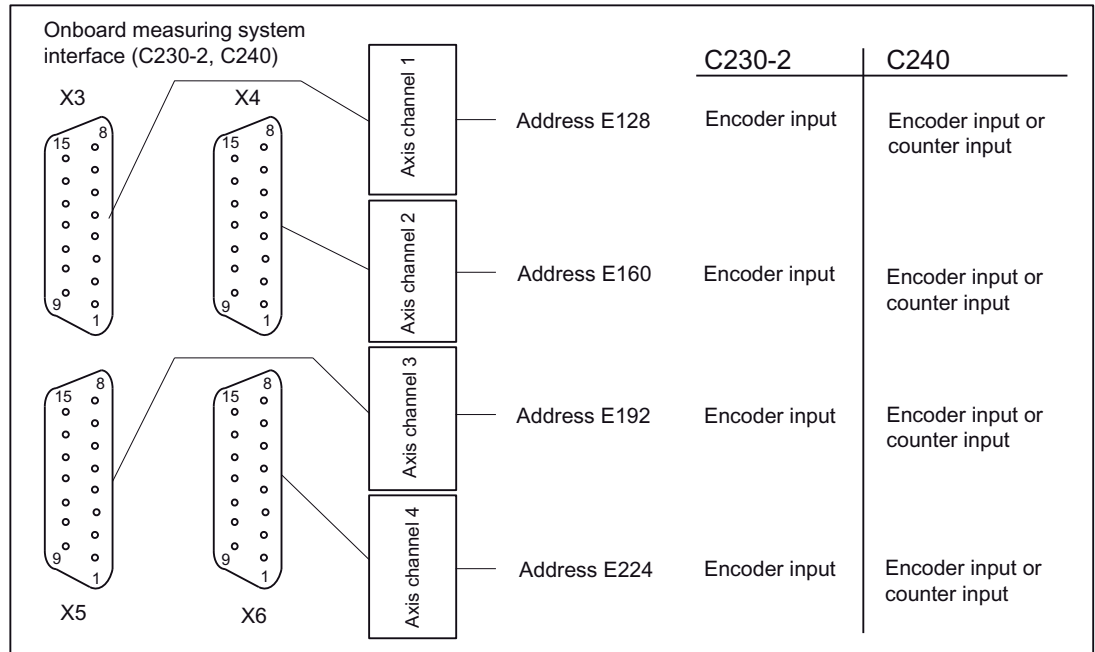

Figure 6-8 Addressing the onboard measuring system interface

Commissioning

7.1 Requirements for commissioning

Requirements

Table 7- 1 Requirements

Prerequisite action	See ...
Your system with SIMOTION C is installed.	ChapterInstalling (Page 84)
Your system with SIMOTION C is wired.	ChapterWiring (Page 91)
For networking via PROFIBUS DP <ul style="list-style-type: none"> • The PROFIBUS addresses of the bus nodes with which the SIMOTION C communicates, are set. • The terminating resistors are switched on (at segment ends). When networking via the Ethernet, the IP address / subnet mask of the bus nodes with which the SIMOTION C communicates, are set. When networking via PROFINET IO, the PROFINET device names of the bus nodes with which the C240 PN communicates, are set	ChapterNetworking (Page 122) ChapterConfiguring an Ethernet subnet on the Ethernet interface (Page 127) ChapterConfiguring an Ethernet subnet on the PROFINET interface (C240 PN) (Page 129)

System requirements

Note

The readme file for the software version you are using provides information about the hardware and software requirements.

Please take note of the information on the current CD for "SIMOTION SCOUT"!

For online operation, a connection must be established between the PG/PC and the SIMOTION C via PROFIBUS DP, Ethernet or PROFINET (C240 PN), see chapter Overview of wiring diagram (Page 94).

The programming device must be equipped with a PROFIBUS or Ethernet card.

You need an MMC adapter to write to the micro memory card (SIMOTION Kernel update) on the PG/PC, see chapter Writing, formatting and erasing the Micro Memory Card (Page 147).

Connecting a PG/PC to a SIMOTION C

You can interconnect the programming device / PC

- with the PROFIBUS of SIMOTION C (connector X8 and/or X9) using a connecting cable (see chapter Network components for a PROFIBUS subnet (Page 125)).

Information on the respective cable lengths for PROFIBUS DP can be found in chapter Onboard measuring system interface (C230-2, C240) (Page 52).

- to the Ethernet of the SIMOTION C (connector X7) with a shielded twisted pair cable.

For information about cabling the Ethernet subnet, refer to chapter Configuring an Ethernet subnet on the Ethernet interface (Page 127).

- to the PROFINET interface X11 (port P1, P2 or P3) of the C240 PN with a shielded twisted pair cable.

For information about cabling the PROFINET subnet, refer to chapter Configuring an Ethernet subnet on the PROFINET interface (C240 PN) (Page 129).

7.2 Inserting and changing the Micro Memory Card

Procedure:

1. Switch off the power supply module.
2. Is a micro memory card inserted? If yes: remove the memory card.

An ejector is located on the frame of the module receptacle to enable you to remove the micro memory card.

Press the ejector and remove the micro memory card.

3. Applying slight pressure, insert the ("new") micro memory card into the slot of the SIMOTION C until it snaps into place. Make sure the beveled edge of the micro memory card faces the ejector (see the following figure).
4. Switch the power supply module on again.

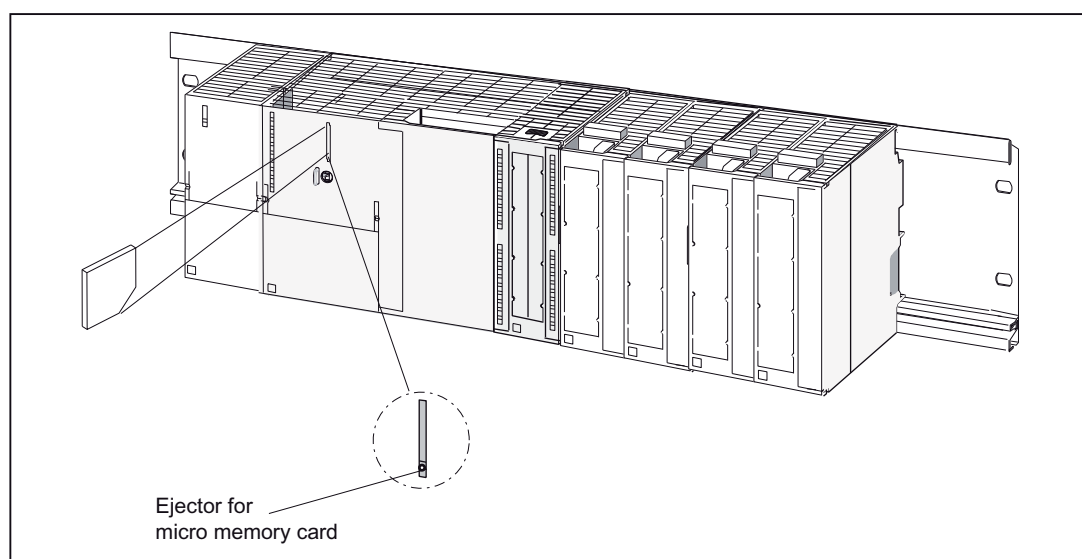

Figure 7-1 Inserting the micro memory card into the SIMOTION C

Note

With the **SIMOTION C240 / C240 PN**, the micro memory card must **always** be inserted for operation.

For the purpose of data backup, the contents of the micro memory card can be copied to the hard drive of a PG/PC with an MMC card reader.

7.3 Initial Power ON

Requirements

- You have completed installation and the wiring of your system with SIMOTION C.
- The micro memory card is inserted.
- The mode selector must be set to STOP!

Initial Power ON

Switch on the power supply module.

- The 24 VDC LED on the power supply module is illuminated.
- On the SIMOTION C:
 - The 5 VDC LED illuminates.
 - All other LEDs light up briefly (approx. 2 seconds).

Note

For C230-2

With an empty micro memory card, the SIMOTION Kernel on the C230-2 is copied to the micro memory card during power-up. This increases the duration of the power-up by about 1.5 minutes.

For C240 / C240 PN

If a micro memory card is not inserted in the C240 or if the micro memory card does not contain a SIMOTION Kernel, all LEDs except the RUN LED are illuminated on the SIMOTION C240.

7.4 Writing, formatting and erasing the Micro Memory Card

Writing the micro memory card of SIMOTION C

You can write to the micro memory card as follows:

- Micro memory card is inserted in the SIMOTION C and is written with the "Copy RAM to ROM" menu command (there must be a connection between the programming device and SIMOTION C).

You can store the technology packages and user data (programs, configuration data, parameter assignments) on the micro memory card (see *SIMOTION SCOUT* online help).

- Write to the micro memory card on the PG or PC.

You can write to the micro memory card directly via a PC using a suitable memory card adapter.

This function is required for updating the SIMOTION C.

You can write the user project with SIMOTION SCOUT and the menu command "Load to file system" directly from the PC to the memory card (micro memory card). To do this, select the device in the project navigator and execute the "Load to file system" command in the context menu.

Note the following information when handling a micro memory card.

Note

The micro memory card always comes formatted! With the **C240 / C240 PN**, the SIMOTION Kernel is located on the micro memory card.

In order to ensure error-free functioning of the micro memory card in the SIMOTION C, the card must **not** be repartitioned.

Using Windows media to modify or delete files on the micro memory card that were written with "Copy RAM to ROM" can destroy the project.

With the **C230-2**, the following information must also be noted.

Note

The micro memory card for the C230-2 can only be formatted in the "SIMOTION SCOUT" engineering system.

As of Kernel Version 3.1, you will **no longer** be able to format the micro memory card by means of the C230-2 mode selector.

The card must **not** be formatted with the PC.

Any saved license keys are also deleted during formatting. The license key must then be reentered via SIMOTION SCOUT.

7.4 Writing, formatting and erasing the Micro Memory Card

The micro memory card can be formatted by calling this function in "SIMOTION SCOUT" (see *SIMOTION SCOUT* online help).

Note

As of Kernel Version 2.1 in the C230-2 and micro memory card 6AU1 700-0AA02-0AA0, the C230-2 transfers its stored kernel to the micro memory card after formatting **only** after the C230-2 has been restarted. When the kernel is transferred, all LEDs on the C230-2 flash. If a specific kernel version is required, it must be placed on the micro memory card manually.

If the C230-2 is switched off or de-energized during commissioning, this could damage the file system on the micro memory card (data on the card can no longer be read). If this occurs, the micro memory card **must** be reformatted.

The micro memory card must **not** be removed when energized.

Repairing the micro memory card

You can repair the micro memory card, for example, if it is faulty. The MMC card can be inserted in a USB Flash card reader and formatted by means of Windows (FAT file system). After it is formatted, the boot sector of the card must be rewritten to by means of SCOUT ("Options" > "Write to Boot Sector...").

With the micro memory card for the C240, the SIMOTION Kernel must be copied to the micro memory card again, see chapter Kernel update for SIMOTION C240 / C240 PN (Page 161).

7.5 User memory concept

7.5.1 SIMOTION C memory model

The following figure provides an overview of the SIMOTION C memory model.

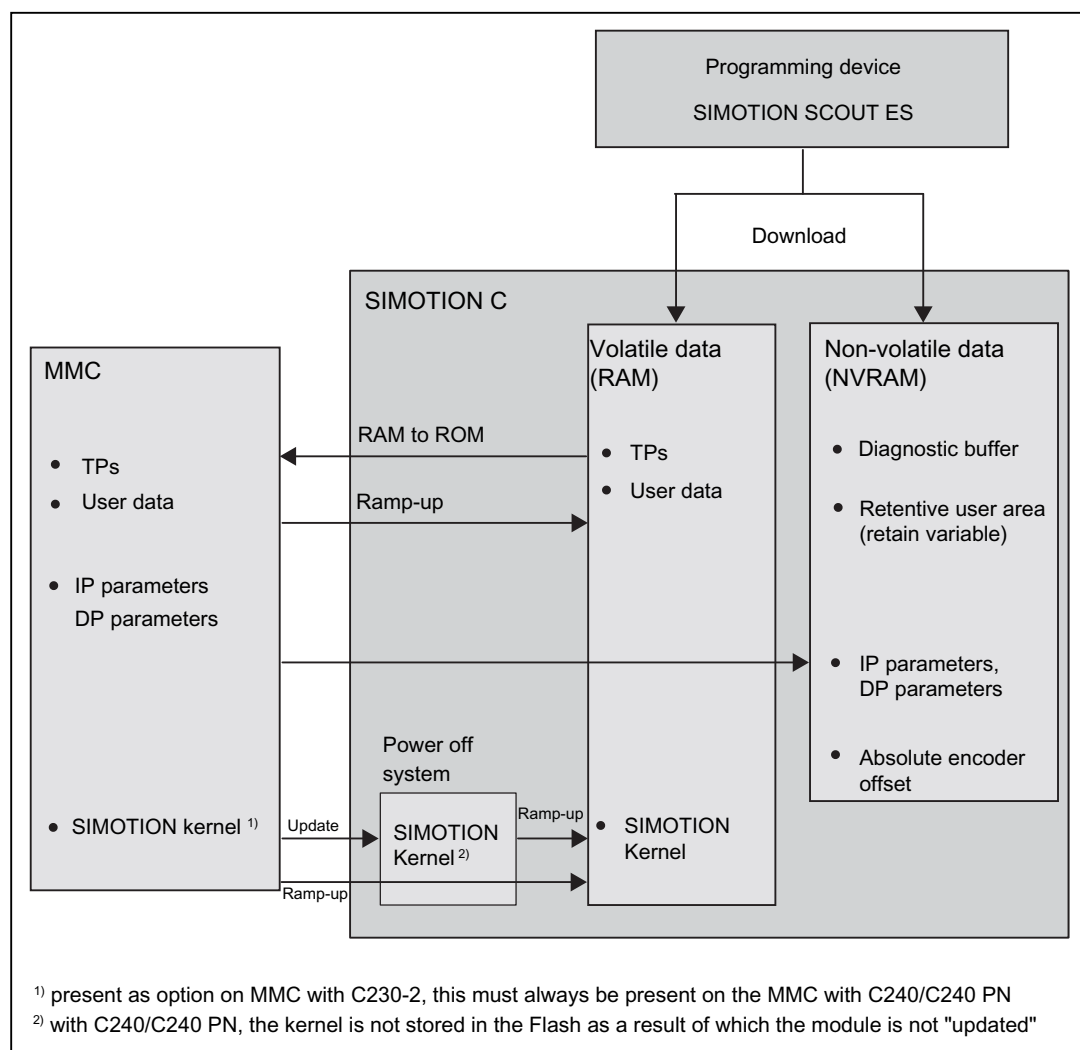

Figure 7-2 SIMOTION C memory model

In the following sections, you will learn information about the user memories and the steps involved in certain operations.

See also

Overview of data deletion (Page 154)

7.5.2 Properties of the user memory

Non-volatile data (NVRAM)

Non-volatile data is used with the objective of retaining user- and system-relevant data when the SIMOTION C is de-energized. You will find information about the area that can be used for non-volatile data in the SIMOTION SCOUT Configuration Manual.

The following non-volatile data is available in a SIMOTION C:

Table 7- 2 Content of non-volatile data

Non-volatile data	Content
Kernel data	<ul style="list-style-type: none"> • Last operating state • IP parameters (IP address, subnet mask, router address) • DP parameters (DP addresses, baud rate) • Diagnostic buffer
Retain variables	<ul style="list-style-type: none"> • Variables in the interface or implementation section of a UNIT declared with VAR_GLOBAL RETAIN • Global device variables set with the "RETAIN" attribute
Retain TO	<ul style="list-style-type: none"> • Absolute encoder offset

The non-volatile data of a SIMOTION C has the following properties:

Table 7- 3 Properties of non-volatile data

Property	Meaning
Location	In the NVRAM of the SIMOTION C, no back-up battery required
Backup time	Unlimited

Note

IP and DP parameters in non-volatile data

If there is a configuration on the MMC, the IP and DP parameters are loaded from the MMC during ramp-up, written to the non-volatile data and used by the SIMOTION C. The SIMOTION C uses the addresses defined in these parameters to go online. The IP and DP parameters in the non-volatile data are retained and used by the SIMOTION C if a ramp-up is performed with an MMC that does not contain a configuration.

A SIMOTION C can therefore always go online if a configuration has been loaded at least once with the SIMOTION SCOUT, or if the SIMOTION C has been ramped up once with an MMC.

Volatile data (RAM)

Definition of the properties of volatile data:

- The volatile data is located in the RAM memory of the SIMOTION C.
- The download data of SIMOTION SCOUT are written to this memory.
- This data is lost when the SIMOTION C is shut down.
- Contents of the "volatile data" area:
 - SIMOTION Kernel
 - Technology packages (TP)
 - User data (programs, configuration data, parameterizations, task configuration)

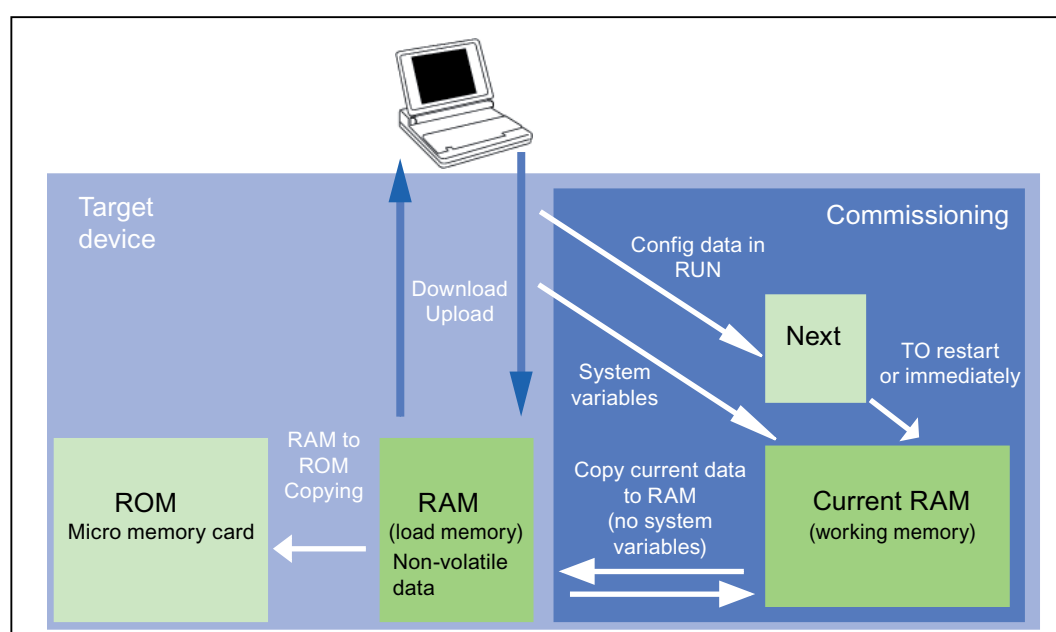

Figure 7-3 Configuration data and system variables on volatile memory

Non-volatile system

With the SIMOTION C230-2, the SIMOTION Kernel is stored as non-volatile data in a flash memory. A C230-2 can therefore also ramp up without a memory card.

MMC memory card

The MMC contains the following data:

- SIMOTION Kernel
- Technology packages (TP)
- User data (programs, configuration data, parameterizations, task configuration)
- IP parameters (IP address, subnet mask, router address)
- DP parameters (DP addresses, baud rate)

7.5.3 Operations and their effect on the user memory

The next section describes the operations identified in the "SIMOTION C memory model" figure by arrows and their effect on the user memory.

SIMOTION SCOUT download

The "Download" command transfers the following data from the engineering system to the "volatile data" area:

- User data (programs, configuration data, parameterizations, task configuration)
- Technology packages

The IP and DP parameters are also saved to the "non-volatile data". Depending on the setting in SIMOTION SCOUT, the retain variables are set to their initial values.

The "volatile data" is lost if the SIMOTION C is switched off after a download without having performed a "Copy RAM to ROM".

Copy RAM to ROM

The "Copy RAM to ROM" command is used on the engineering system to save the following data to the MMC:

- Technology packages and user data (programs, configuration data, parameterizations, task configuration) of the "volatile data" area
- Depending on the setting in SIMOTION SCOUT, actual values can be copied to the "volatile data" area before copying the data from RAM to ROM.

Note

The "Copy RAM to ROM" command does not save the actual values of the retain variables to the MMC.

SIMOTION C ramp-up

During ramp-up, the SIMOTION Kernel is loaded to the "volatile data" area. A C230-2 loads the kernel from the "non-volatile system" (integrated flash in the device), a C240/C240PN loads the kernel from the MMC.

The following data is also loaded from the MMC during ramp-up:

- Technology packages and user data to the "volatile data"
- IP and DP parameters to the "non-volatile data"

SIMOTION Kernel update (only valid for SIMOTION C230-2)

An update writes the SIMOTION Kernel from the micro memory card to the "non-volatile system". If a newer or an older version of the SIMOTION Kernel is to be installed, an update can be performed with a micro memory card that contains the appropriate SIMOTION Kernel.

Backup of non-volatile data

The "_savePersistentMemoryData" system function is used to save the contents of "non-volatile data" to the MMC. This backup prevents the retain variables and the absolute encoder position from being lost if a component is replaced.

The backup copy is saved to the "PMEMORY.XML" backup file in the "USER/SIMOTION" folder. On the system side, this system function ensures that a consistent overall image of the non-volatile data is always available the next time the unit is powered on, even if there is a power failure during backup. An already existing backup file is renamed to "PMEMORY.BAK" before a new backup file is generated. If the backup to this new file fails (for example, due to insufficient storage capacity of the memory card), the existing backup file is used in the next attempt to restore the content of the "non-volatile data". The backup file is deleted if the new file was successfully created.

NOTICE

If you do not save the "non-volatile data" to the MMC, it is lost when a spare part is used (in the event of a module defect).

If an absolute encoder overflow occurs after **_savePersistentMemoryData**, the actual position value is no longer correct after the non-volatile data is restored. In this case, homing (absolute encoder adjustment) must be repeated.

Power failure

The "non-volatile data" is saved to the NVRAM of the SIMOTION C during a power failure. The "non-volatile data" is available again at the next ramp-up. Thus, the SIMOTION C is immediately ready for operation without data loss.

7.6 Deleting data

7.6.1 Overview of data deletion

You can define the scope of data to be deleted from SIMOTION C memory described in the "user memory concept". This enables you to determine whether data in your system should be deleted completely or partially.

You have the following options for deleting SIMOTION C data:

- SIMOTION C memory reset
- Deleting user data from the micro memory card
- Setting SIMOTION C to factory settings

See also

SIMOTION C memory model (Page 149)

7.6.2 SIMOTION C memory reset

Introduction

During the memory reset, the "volatile data" in the RAM of the SIMOTION C and the "non-volatile data" in the NVRAM, except for the communication configuration (baud rates, network addresses, etc.), is deleted. The data on the MMC is retained during the memory reset.

You must perform a memory reset of the SIMOTION C:

- When you want to undo changes you have made to your user data (programs, configuration data, parameter assignments) that you have not backed up with the "Copy RAM to ROM" menu command.
- If the SIMOTION C requests a memory reset with a flashing STOP LED (slow flashing) (e.g. micro memory card has been removed).
- The "non-volatile data" does not match the project on the MMC and therefore an error occurs.

You can perform the memory reset online via SIMOTION SCOUT or offline via the mode selector on the SIMOTION C.

Data deleted on memory reset

The following data is deleted during a memory reset:

- User data (programs, configuration data, parameterizations, task configuration)
- Technology packages
- Retain TO (absolute encoder adjustment)
- Retain variables

Retain variables are variables in the interface or implementation section of a UNIT that are declared with VAR_GLOBAL RETAIN, or global device variables with the RETAIN attribute.

Note

Absolute encoder data is deleted during a memory reset operation and must therefore be readjusted after the memory reset.

Reset-proof data

The following data is retained during a memory reset:

- TCP/IP and DP parameters
- Diagnostic buffer
- Data that was saved with the _savePersistentMemoryData, _saveUnitDataSet, exportUnitDataSet and RAMtoROM commands

If backup files (PMEMORY.XML/PMEMORY.BAK) have been backed up with _savePersistentMemoryData, the data in these files is backed up again to the non-volatile data after the memory reset. Users can therefore force the restoration of non-volatile data by means of memory reset.

- Licenses

The technology packages and user data (configuration data, programs, parameterizations) that were previously backed up to the micro memory card using the "Copy RAM to ROM" menu command will be transferred to the "non-volatile data" area of the SIMOTION C during the next ramp-up. **Thus, an existing configuration on the MMC is loaded to the SIMOTION device following the memory reset.**

Memory reset by means of SIMOTION SCOUT

1. In SIMOTION SCOUT, select the "Target system" > "Control operating mode" menu command.

The dialog "C2xx: operating mode" is opened.

2. Select MRES mode to perform the memory reset.

Memory reset with the mode selector

Note

The operation for the memory reset with the toggle switch is described below. The operation with the key-operated switch of the C230-2 is similar to the operation with the toggle switch.

Proceed as follows (see following figure):

1. Set the mode selector to STOP.
2. Move the switch to MRES and hold the switch in this position until the STOP LED changes from flashing to steady illumination.
3. Within 3 seconds, you must release the switch and return it to the MRES position. The memory reset will now be performed. All the LEDs will light up during this time. The SIMOTION C completed the memory reset when the STOP LED lights up.

The SIMOTION C has reset the memory.

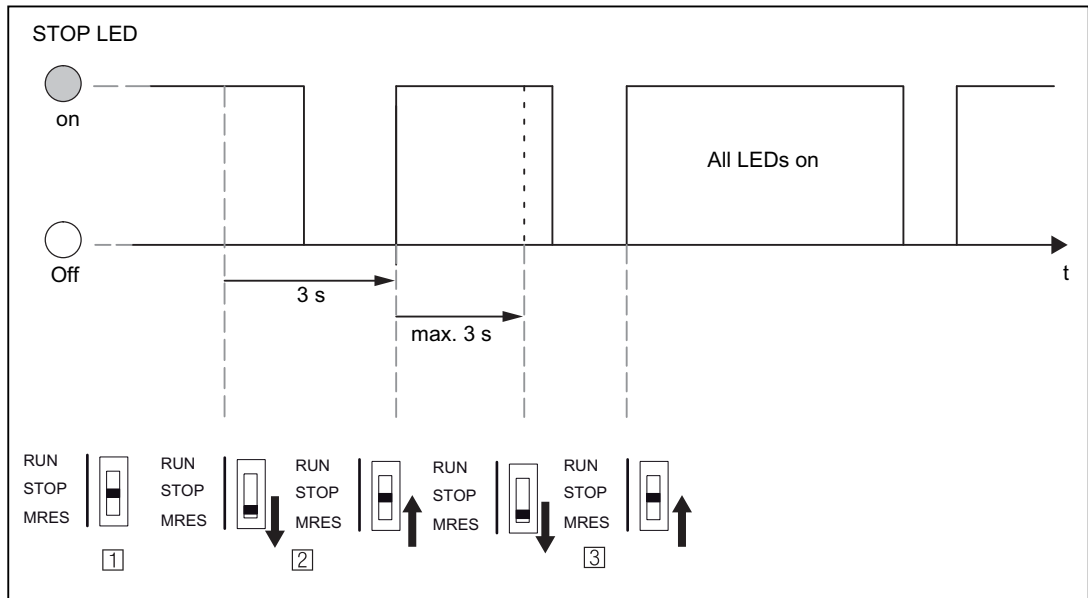

Figure 7-4 Mode selector operation sequence for the memory reset

7.6.3 Deleting user data from Micro Memory Card

Requirement

You can delete user data with SIMOTION SCOUT. To do so, you must be online on the SIMOTION C. The following data is deleted during this operation:

- User data in the volatile data
- Non-volatile data, except for the IP and DP parameters
- User data on the MMC (user directories)

You can thus continue to go online to the SIMOTION C with your PG/PC. The licenses on the MMC are retained.

Deleting user data

1. In SIMOTION SCOUT, open the project you want to modify.
2. Go online with the SIMOTION C.
3. Select the "Delete user data on card" option in the "Target system" menu.
4. Confirm the "Delete User Data from Card" prompt with "OK".

The user data are deleted.

7.6.4 Setting SIMOTION C to factory settings

Overview

SIMOTION C is supplied with preset parameters, such as the transmission rate or PROFIBUS addresses. You can restore the factory settings with the mode selector. The following data is deleted during this operation:

- "Non-volatile data" in the SIMOTION device
- The backup (PMEMORY.XML/PMEMORY.BAK) of the non-volatile data on the MMC
- User data in the "volatile data" and on the MMC
- The communication configuration (IP and DP parameters) is set to the factory settings

The licenses on the micro memory card are retained.

Operations on the mode selector

Proceed as follows:

1. Switch off the power supply for SIMOTION C.
2. The micro memory card is inserted in the SIMOTION C.
3. Switch the mode selector to the MRES position. Keep this position selected and switch the power supply for the SIMOTION C on. When the "STOPU" LED flickers, switch back to the STOP position again.

Note

The communication configuration is now reset to the factory settings. The communication configuration for the SIMOTION C must be repeated.

See also

Factory setting (Page 131)

Maintenance and servicing

8.1 SIMOTION kernel update

8.1.1 Kernel update for SIMOTION C230-2

Each C230-2 always contains the latest version of the SIMOTION Kernel when it is delivered. The user can install newer or older versions via an update.

The corresponding SIMOTION Kernel version is included on the respective SIMOTION SCOUT Add-On CD-ROM. (Proceed in the same way with a SIMOTION SCOUT DVD)

Note:

The SIMOTION Kernel and the technology packages must always have the same software version. To avoid incompatibilities when replacing the C230-2, it is recommended that the SIMOTION Kernel version of the current configuration is stored on the micro memory card.

You can use a PG/PC with the appropriate micro memory card adapter to copy the SIMOTION Kernel to the micro memory card.

Proceed as follows:

1. Connect the SC card / MMC adapter to your PG/PC and insert the micro memory card in the module slot of the adapter.
2. Insert the CD ROM containing the SIMOTION Kernel in the CD drive of your PG/PC.
3. Open Windows Explorer.

Note

The micro memory card must be visible as a drive with an arbitrary letter in the Windows Explorer.

4. Delete all files and folders from the MMC except for the complete KEYS folder. The KEYS.TXT file in this folder contains the license key and must be retained.
5. Unpack the firmware contained in the ZIP file (\\3_C2xx\Firmware_C230\V...\c230_2fw.zip) on the CD-ROM and copy the c230_2fw.bin file using the Windows Explorer to the root directory of the micro memory card.
6. Remove the micro memory card from the PG/PC.
7. Switch off the power supply for the C230-2.

8.1 SIMOTION kernel update

8. Insert the prepared micro memory card into the C230-2.

9. Switch on the power supply for the C230-2.

The C230-2 compares the version of the SIMOTION Kernel on the micro memory card with that on the C230-2 and automatically carries out an update.

- First, the version of the SIMOTION Kernel stored in the C230-2 is deleted. The "RUN", "STOP" and "BUS2F" LEDs flash.
- Then the new version of the SIMOTION Kernel is transferred from the micro memory card to the C230-2. During the data transfer, the "SF", "RUN", "STOPU", "STOP", "BUS1F" and "BUS2F" LEDs illuminate in sequence.

Note: The C230-2 must **not** be switched off during this phase.

- After completing the SIMOTION Kernel update, the C230-2 performs a restart and goes into the STOP mode.

The C230-2 can then be operated with the new SIMOTION Kernel.

Note

Following an update, if problems occur during restart, the "SF" LED will illuminate or the "STOPU", "STOP", "BUS1F", and "BUS2F" LEDs will flicker. This means that the update was not completed correctly.

To remedy this error, proceed as follows:

- Power OFF/ON
- Check whether the restart is being performed correctly

If the error occurs again, repeat the update or replace the module.

8.1.2 Kernel update for SIMOTION C240 / C240 PN

The C240 / C240 PN does not contain any firmware.

The micro memory card of the C240 / C240 PN always contains the latest version of the SIMOTION Kernel when it is delivered. The user can install newer or older versions via an update.

The corresponding SIMOTION Kernel version is included on the respective SIMOTION SCOUT Add-On CD-ROM. (Proceed in the same way with a SIMOTION SCOUT DVD)

Note:

The SIMOTION Kernel and the technology packages must always have the same software version.

You can use a PG/PC with the appropriate micro memory card adapter to copy the SIMOTION Kernel to the micro memory card.

Proceed as follows:

1. Connect the SD card / MMC adapter to your PG/PC and insert the micro memory card in the slot of the adapter.
2. Insert the CD ROM containing the SIMOTION Kernel in the CD drive of your PG/PC.
3. Open Windows Explorer.

Note

The micro memory card must be visible as a drive with an arbitrary letter in the Windows Explorer.

4. Delete all files and folders from the MMC except for the complete KEYS folder. The KEYS.TXT file in this folder contains the license key and must be retained.
5. Unpack the firmware contained in the ZIP file (\3_C2xx\Firmware_C240\...\c240_fw.zip) on the CD-ROM and copy the following files and folders to the root directory of the micro memory card using Windows Explorer.
 - c240_fw1.bin
 - c240_fw2.bin
 - c240_fw.bin
 - startup.txt
 - toc.txt
 - SIEMENS\SIMOTION\cbe30.ufw
6. Remove the micro memory card from the PG/PC.
7. Switch off the power supply to the C240 / C240 PN.
8. Insert the prepared micro memory card into the C240 / C240 PN.
9. Switch on the power supply to the C240 / C240 PN.

The C240 / C240 PN can then be operated with the new SIMOTION Kernel.

Note

If the micro memory card does not contain a SIMOTION Kernel, all LEDs on the SIMOTION C240 / C240 PN apart from the RUN LED are illuminated.

8.2 Removal and replacement of the SIMOTION C

Overview

You can only replace SIMOTION C as a complete unit.

 **WARNING**

The SIMOTION C can only be replaced when the load power supply is switched off. You must therefore switch off the power supply, e.g. by means of the on/off switch on the PS module.

Removing a faulty module

To remove the SIMOTION C, proceed as follows:

1. Switch off the power supply.
2. Remove the micro memory card.
3. Open the front door panels. If necessary, remove the labeling strips.
4. Undo the connections on the terminal strip for the power supply.
5. Depending on the controller used, disconnect the encoders (X3...X6), the drive unit (X2), the PROFIBUS DP interfaces (X8, X9) as well as the Ethernet (X7) and PROFINET interfaces (X11 P1 to X11 P3).
6. Loosen the mounting screw in the middle of the front connector (X1) and then pull out the front connector, holding it at the gripping points provided.
7. Unscrew the module's mounting screws and swing it upwards and out.

Installing a new module

Procedure:

1. Remove the upper part of the front connector coding from the new module.
2. Insert a module of the same type, swing it down and screw it in tightly.
3. Insert the front connector and then tighten the mounting screw.
4. Depending on the controller used, connect the encoders (X3...X6), the drive unit (X2), the PROFIBUS DP interfaces (X8, X9) as well as the Ethernet (X7) and PROFINET interfaces (X11 P1 to X11 P3).
5. Connect the load power supply on the terminal strip.
6. Close the front panel doors and put in the labeling strips.
The controller is once again ready for operation and can be commissioned.
7. Insert the micro memory card.
8. Switch on the power supply.

8.3 Module replacement without programming device or PC

Overview

If a defective SIMOTION C has to be replaced without using a PG/PC, you can transfer the data of the defective module to the new module by simply inserting the micro memory card of the defective module in the new module.

Requirement

When you commissioned your project, you must have used the menu command "Copy RAM to ROM" of the SIMOTION SCOUT to save your project to the micro memory card, as described in the chapter "User memory concept".

The following data are on the micro memory card and can be transferred to the new module:

- Technology packages (TP)
- User data (programs, configuration data, parameterizations, task configuration)
- DP parameters (DP addresses, baud rate)
- IP parameters (IP address, subnet mask, router address)

As the non-volatile data is in a memory within the module, it is lost when the module is replaced.

If the non-volatile data is to be transferred to the new module, it must first be backed up on the micro memory card of the module to be replaced. The restoration of the non-volatile data must be triggered via a memory reset on the new module.

Note

If the non-volatile data is not restored, the retain variables are set to their initial values and the diagnostics buffer with the history from the old module is no longer available.

Alarm, error, and system messages

9.1 Diagnosis using the LEDs

Diagnostic LEDs

The LEDs are explained in the order in which they are positioned on the SIMOTION C.

Table 9- 1 Diagnostics LEDs of the SIMOTION C

Display	Meaning	Explanations
SF (red)	System fault	This LED indicates a fault on the SIMOTION C.
LED - ON		An event which can be acknowledged is present (alarm, message, note). (see documentation package <i>SIMOTION System and Function Descriptions</i>)
LED - flashing (0.5 Hz)		No license exists for technology/optional objects under license. Technology/option objects under license include, for example: <ul style="list-style-type: none"> • Cam (synchronous axes with connected cam) • Ethernet (Ethernet interface) • TControl (Temperature Control)
LED - OFF		SIMOTION C is operating without error.
5 VDC (green)	Power supply for the electronics	This LED indicates that the power supply is ready.
LED - ON		The power supply of the SIMOTION C is operating without error.
LED - OFF		If this is not illuminated, the reason may be: <ul style="list-style-type: none"> • No connected or switched-on network • No specified load power supply connected • Module not connected correctly • Module defective
RUN (green)	SIMOTION C in RUN mode	This LED indicates that the user program is running.
LED - ON		See RUN (green)
LED - flashing (2 Hz)		The time between selection of "RUN" mode until this mode has been attained is indicated by the LED flashing.
STOPU (yellow)	SIMOTION C in STOP user program mode	This LED indicates that the technology packages are active. A user program is not being executed.
LED - ON		See STOPU (yellow)
LED - flashing (2 Hz)		The time from when the "STOPU" operating mode is selected until this operating mode has been attained is indicated by the LED flashing.
LED - "flickering"		Formatting the micro memory card

9.1 Diagnosis using the LEDs

Display	Meaning	Explanations
STOP (yellow)	SIMOTION C in STOP mode	This LED indicates that a user program is not running. The technology packages are inactive.
LED - ON		See STOP (yellow)
LED - flashing (2 Hz)		The time from when the "STOP" operating mode is selected until this operating mode has been attained is indicated by the LED flashing.
LED - flashing (0.5 Hz)		A memory reset request is indicated by slow flashing, see chapter SIMOTION C memory reset (Page 154).
BUS1F (X8) (red) or BUS2F (X9) (red)	Fault on interface	This LED indicates a fault on the PROFIBUS DP interface.
LED - ON		<i>Interface configured as slave:</i> Bus fault Search for baud rate
LED - flashing (0.5 Hz)		Parameterization error No cyclic data exchange
LED - OFF		Cyclic data exchange
LED - ON		<i>Interface configured as master:</i> Bus fault (bus short circuit)
LED - flashing (0.5 Hz)		Bus fault (slaves have failed or cable faulty)
LED - OFF		No fault or no interface configured

Table 9- 2 Status and fault displays behind the front cover

Display	Meaning	Explanations
Link X7 (green)	Link status of Ethernet interface	This LED indicates a physical connection of the Ethernet interface X7.
LED - ON		A device is connected and there is a physical connection to this device.
LED - OFF		A device is not connected and there is no physical connection.
Activity X7 (yellow)	Activity status of Ethernet interface	This LED indicates a data transfer via the Ethernet interface X7.
LED - flashing		Data is being received or transmitted.
LED - OFF		Data is not being received or transmitted.
Link X11 Px (green)	Link status of PROFINET interface	This LED indicates a physical connection of the PROFINET interface X11 at port x (1 to 3).
LED - ON		A device is connected and there is a physical connection to this device.
LED - OFF		A device is not connected and there is no physical connection.
Activity X11 Px (yellow)	Activity status of PROFINET interface	This LED indicates a data transfer via the PROFINET interface X11 at port x (1 to 3).
LED flashing or LED ON		Data is being received or transmitted.
LED - OFF		Data is not being received or transmitted.
Fault X11 (red)	Fault status of PROFINET interface	This LED indicates a fault at the PROFINET interface X11.
LED - OFF		PROFINET interface is operating without error; the data exchange to all configured I/O devices is running.
LED - flashing (2 Hz) ¹⁾		Bus fault <ul style="list-style-type: none"> • Failure of a connected I/O device. • At least one of the assigned I/O devices cannot be addressed • Incorrect or no configuration

Display	Meaning	Explanations
Sync X11 (green) ²⁾	Sync status of PROFINET interface	This LED indicates the synchronization status of the PROFINET interface X11.
LED - OFF		<p>The PROFINET interface has not synchronized yet to the send cycle of IRT or PROFINET with IRT has not been configured (e.g. only RT or TCP/IP operation). If no PROFINET IO with IRT has been configured, then generally there is no synchronization of the PROFINET interface. If isochronous data has been configured for the SIMOTION device, the PROFINET interface generates a local substitute cycle of the same size as the configured send cycle of IRT, as long as no synchronization has been performed to the send cycle of IRT:</p> <ul style="list-style-type: none"> • The task system of SIMOTION has synchronized to the local substitute cycle of the PROFINET interface. • DP interfaces, if configured as isochronous, are synchronized to the local substitute cycle of the PROFINET interface.
LED - flashing (2 Hz)		<p>The PROFINET interface has synchronized to the send cycle of IRT. If isochronous data has been configured for SIMOTION, then the following applies:</p> <ul style="list-style-type: none"> • The task system of SIMOTION has synchronized to the send cycle of IRT. • DP interfaces, if configured as isochronous, have not synchronized yet to the send cycle of IRT.
LED - ON		<p>The PROFINET interface has synchronized to the send cycle of IRT. If isochronous data has been configured, then the following applies:</p> <ul style="list-style-type: none"> • The task system of SIMOTION has synchronized to the send cycle of IRT. • DP interfaces, if configured as isochronous, are synchronized to the send cycle of IRT. <p>If no isochronous data has been configured for SIMOTION, this state indicates that only the PROFINET interface has synchronized to the send cycle of IRT. The PROFINET interface is then used to forward the data. Isochronous data means that data is exchanged with a further device on PROFINET with configured RT class IRT and isochronous application/device.</p>

1) Minimum flashing duration 3 s

2) If no PROFINET IO with IRT has been configured, then generally no synchronization will be made to the send cycle.

Note

During ramp-up of the SIMOTION C, the LEDs on the housing front are briefly illuminated.

You can carry out a detailed diagnosis with a programming device or PC and the engineering system.

Projects cannot be downloaded in **STOPU** mode.

9.2 Combinations of LED displays

Combination of LED displays

The following table provides an overview of all permissible and/or required LED display combinations.

The meaning of the symbols used in the table is as follows:

1	LED on
0	LED off
0,5/1	LED flashing (0.5 Hz)
2/1	LED flashing (2 Hz)
☆	LED flickers
→	Running light
x	LED may light up

Table 9-3 Summary of LED displays

Meaning	LED displays						
	SF (red)	5 VDC (green)	RUN (green)	STOPU (yellow)	STOP (yellow)	BUS1F (red)	BUS2F (red)
Ramp-up (C230-2)	1 0 0	1 1 1	1 0 0	1 ☆ 0	1 0 2/1	1 0 0	1 0 0
Ramp-up (C240 / C240 PN)	1 0 0 0 0	1 1 1 1 1	1 ☆ 0 0 0	1 0 ☆ → 0	1 0 0 → 2/1	1 0 0 0 0	1 0 0 0 0
STOPU → RUN	x	1	2/1	1	0	x	x
RUN	x	1	1	0	0	x	x
RUN → STOPU	x	1	1	2/1	0	x	x
STOPU	x	1	0	1	0	x	x
STOPU → STOP	x	1	0	1	2/1	x	x
STOP	x	1	0	0	1	x	x
STOP → STOPU	x	1	0	2/1	1	x	x
Defective operating mode To correct or avoid errors: • Switch SIMOTION C Off/On • Check diagnostic buffer	0	1	1	☆	☆	☆	☆
Power supply is ready for operation	x	1	x	x	x	x	x
Write to micro memory card (copy RAM to ROM)	x	1	0	0	☆	x	x

Meaning	LED displays						
	SF (red)	5 VDC (green)	RUN (green)	STOPU (yellow)	STOP (yellow)	BUS1F (red)	BUS2F (red)
Formatting the micro memory card	x	1	0	☆	2/1	x	x
Request for memory reset by the SIMOTION C or via the mode selector of the SIMOTION C	x	1	0	0	0,5/1	x	x
Memory reset in progress	1	1	1	1	1	1	1
Memory reset complete	x	1	0	0	1	x	x
SIMOTION Kernel update is running (SIMOTION C230-2 only)	→	1	→	→	→	→	→
SIMOTION Kernel update is complete (SIMOTION C230-2 only)	x	1	0	0	1	x	x
SIMOTION C240 without micro memory card	1	1	0	1	1	1	1
Copy SIMOTION Kernel to micro memory card	0,5/1	1	0,5/1	0,5/1	0,5/1	0,5/1	0,5/1
SIMOTION C is operating without error.	0	1	x	x	x	0	0
An interrupt that can be acknowledged (alarm, message, note) is pending	1	1	x	x	x	x	x
Fault to which the user program cannot respond. The following actions may be required to rectify the fault: <ul style="list-style-type: none"> • Power OFF/ON • Check micro memory card • New commissioning procedure • Replacement of SIMOTION C 	x	1	x	☆	☆	☆	☆
No license exists for technology/optional objects under license	0,5/1	1	x	x	x	x	x
SIMOTION - HOLD status User program is running at the break point	x	1	0,5/1	1	1	x	x
PROFIBUS DP interface as slave							
Bus fault Searching for baud rate	x	1	x	x	x	1	1
Parameterization error No cyclic data exchange	x	1	x	x	x	0,5/1	0,5/1
Cyclic data exchange	x	1	x	x	x	0	0
PROFIBUS DP interface as master							
Bus fault (bus short-circuit)	x	1	x	x	x	1	1
Bus fault (slaves have failed or cable faulty)	x	1	x	x	x	0,5/1	0,5/1
No fault or no interface configured	x	1	x	x	x	0	0

Technical data

10.1 Technical data

Memory for system data

Table 10- 1 Memory for system data

Data	Memory size		
	C230-2	C240	C240 PN
Diagnostic buffer	200 messages		
RAM (Random Access Memory)	20 MB	40 MB	
RAM disk (load memory)	23 MB	23 MB	
Retentive memory	13 KB	107 KB	

For information about user data, refer to chapter Properties of the user memory (Page 150).

System clocks

Table 10- 2 System clocks

System clocks	C230-2	C240	C240 PN
Basic cycle clock (isochronous bus cycle not activated)	1.5 ms to 8 ms	0.5 to 8 ms	
DP cycle clock (isochronous bus cycle activated)	1.5 ms to 8 ms	1.0 to 8 ms	
Position control cycle clock (servo cycle clock)	≥ 1.5 ms	≥ 0.5 ms	
Interpolator cycle clock (IPO cycle clock)	≥ 1.5 ms	≥ 0.5 ms	
Send cycle of PROFINET (C240 PN)	-	-	0.5 to 4 ms

A modification can be made in the engineering system.

For system cycle clock settings, refer to the SIMOTION SCOUT online help.

Note

With the SIMOTION C, errors can occur during **Download** or during the transition from **STOP** to **RUN** if I/O bus modules and a system cycle clock > 8 ms (only with equidistant bus cycle) are used. If an error occurs, set the system cycle clock ≤ 8 ms.

DP slave connections

Table 10-3 Number of DP slave connections

Number of DP slave connections	Max. 64
--------------------------------	---------

PROFINET device connections

Table 10-4 Number of PROFINET device connections

Number of PROFINET device connections	Max. 64
---------------------------------------	---------

Address areas

Table 10-5 Address areas

Input address area, total	<ul style="list-style-type: none"> • 2 Kbytes for C230-2 • 4 Kbytes for C240 / C240 PN
Output address area, total	<ul style="list-style-type: none"> • 2 Kbytes for C230-2 • 4 Kbytes for C240 / C240 PN
Process image inputs	64 bytes
Process image outputs	64 bytes

Connection values

Table 10-6 Connection values

Supply voltage	24 V DC (permissible range: 20.4 to 28.8 V)
Power consumption from 24 V	<ul style="list-style-type: none"> • typically 0.9 A (inputs/outputs open) • typically 1.2 A (with 4 encoders, 5 V) • typically 1.9 A (with 4 encoders, 24 V)
Power loss	15 W
Starting current	8 A
Encoder supply 5 V max. output current	1.2 A
Encoder supply 24 V max. output current	1.2 A

Dimensions and weight

Table 10-7 Dimensions and weight

Dimensions W x H x D [mm]	200 x 125 x 118
Weight [g]	Approximately 1,150

Onboard drive interface (C230-2, C240)

Analog

Table 10- 8 Onboard drive interface

Setpoint signal (analog output)	
Number	4
Rated voltage range	-10.5 to 10.5 V
Output current	-3 to 3 mA
Electrically isolated	No
Load impedance	≥ 3 kOhm
Resolution	<ul style="list-style-type: none"> • 16-bit, including sign (with filter) • 12-bit, including sign (without filter)
Filter time <ul style="list-style-type: none"> • C230-2 • C240 	<ul style="list-style-type: none"> • With filter (C230-2-compatible) • With filter (C230-2 compatible) or without filter (can be switched in HW Config)
Basic error limit (at 25° C) <ul style="list-style-type: none"> • 0 V to 10 V • -10 V to 0 V 	<ul style="list-style-type: none"> • -2 to +6 % (typically +3 %) • -6 to +2 % (typically -3 %)

Relay contact controller enable	
Number	4
Switching voltage	max. 50 V
Switching current	Max. 1 A
Switching capacity	Max. 30 VA
Mechanical service life	Usually 10 ⁹ switching cycles
Electrical service life	Typically 3 · 10 ⁶ switching cycles at 24 V / 1 A

Cable length: Max. 35 m

Stepper drive (C230-2, C240)

Table 10-9 Stepper drive

5 V output signals according to RS422 standard		
Differential output voltage	V_{OD}	Min. 2 V ($R_L = 100 \Omega$)
Output voltage "1"	V_{OH}	3.7 V ($I_o = -20 \text{ mA}$) 4.5 V ($I_o = -100 \mu\text{A}$)
Output voltage "0"	V_{OL}	Max. 1 V ($I_o = 20 \text{ mA}$)
Load impedance	R_L :	min. 55 Ω
Output current	I_o	max. $\pm 60 \text{ mA}$
Pulse frequency	f_P	Max. 750 kHz

Cable length: Max. 50 m

- For mixed operation with analog axes, cable length: 35 m
- For asymmetrical transmission, cable length: 10 m

Actual value latch time

The following table shows the different latch times T_i of the actual encoder values depending on the position control cycle clock.

Table 10- 10 Actual value latch time

Position control cycle clock [μ s]	Actual value latch time T_i [μ s]	
	C230-2	C240
1500	0	0
1750	0	0
2000	0	0
2250	0	0
2500	0	0
2750	0	2
3000	0	0
3250	0	64
3500	0	0
3750	0	127
4000	0	0
4250	0	189
4500	0	0
4750	0	252
5000	0	0
5250	0	314
5500	0	2
5750	0	377
6000	0	0
6250	0	439
6500	0	64
6750	0	502
7000	0	0
7250	0	564
7500	0	127
7750	0	627
8000	0	0

Onboard measuring system interface (C230-2, C240)

Table 10- 11 Onboard measuring system interface

Position measuring	<ul style="list-style-type: none"> • Incremental • Absolute (SSI)
Signal voltages	Inputs: 5 V as per RS422
Supply voltage and current consumption per encoder	<ul style="list-style-type: none"> • 5 V/300 mA • 24 V/300 mA
Input frequency for incremental encoder	Max. 1 MHz
Baud rate for absolute encoder (SSI)	<ul style="list-style-type: none"> • 187.5 / 375 / 750 Kbits/s • 1.5 Mbit/s
Cable length for incremental encoder <ul style="list-style-type: none"> • 5 V encoder supply (tolerance 4.75 to 5.25 V) • 24 V encoder supply (tolerance 10 to 30 V) 	<ul style="list-style-type: none"> • Max. 10 m at 1 MHz • Max. 25 m at 500 kHz and max. 300 mA • Max. 35 m at 500 kHz and max. 210 mA • Max. 100 m at 300 kHz and max. 300 mA
Cable length for absolute encoder (SSI) 24 V encoder supply (tolerance 10 to 30 V)	<ul style="list-style-type: none"> • Max. 250 m at 187.5 Kbits/s • Max. 10 m at 1.5 Mbit/s
Electrically isolated	No
Monitoring	Short-circuit in encoder supply and faulty wire

Digital inputs

Table 10- 12 Digital inputs

Number of inputs	18
Supply voltage	24 V DC (permissible range: 20.4 to 28.8 V)
Input voltage	<ul style="list-style-type: none">• 0 signal: -3...5 V• 1 signal: 11 to 30 V
Input current	<ul style="list-style-type: none">• 0 signal: 15 mA• 1 signal: 6 to 30 mA (typically 8 mA)
Input delay (I0 to I11, B1 to B4, M1 to M2)	<ul style="list-style-type: none">• 0 → 1 signal: 15 μs (typically 6 μs)• 1 → 0 signal: 150 μs (typically 40 μs)
Connection of a 2-wire encoder	Supported
Permissible quiescent current	2 mA
Electrical isolation between inputs	No
Electrical isolation between inputs and logic	Yes
Insulation	500 V DC
Length of cable	Max. 30 m

Digital outputs

Table 10- 13 Digital outputs

Number of outputs	8
Supply voltage	24 V DC (permissible range: $V_L = 20.4$ to 28.8 V)
Output voltage	1 signal: From $V_L^{1)}$ - 0.8 V to $V_L^{1)}$ V
Max. output current	1 signal: 5 mA. to 0.6 A (via supply voltage)
Total current of the outputs	<ul style="list-style-type: none"> • max. 4 A (at 0 to 40° C) • max. 2 A (at 40 to 55° C)
Extinguishing energy per output	400 mJ (not simultaneous)
Lamp load	5 W
Switching rate	<ul style="list-style-type: none"> • 100 Hz (with resistive load) • 2 Hz (with inductive load)
Short-circuit protection	Yes
Max. leakage current	0 signal: 2 mA
Output delay (Q0...Q7)	<ul style="list-style-type: none"> • 0 → 1 signal: 500 μs (typically 150 μs) with $R_L = 60$ Ohm • 1 → 0 signal: 500 μs (typically 150 μs) with $R_L = 60$ Ohm
Electrical isolation between outputs	No
Electrical isolation between outputs and logic	Yes
Insulation	500 V DC
Length of cable	Max. 30 m
1) V_L - Supply voltage of outputs	

Note

The connecting cable between the voltage source and the load current supply connector L+ and the associated reference potential M should **not** exceed a maximum length of 10 m.

READY output (RDY)

Table 10- 14 Electrical parameters of RDY relay contact

RDY relay contact	
Switching voltage DC	max. 50 V
Switching current	Max. 1 A
Switching capacity	Max. 30 VA
Mechanical service life	Usually 10^9 switching cycles
Electrical service life	Typically $3 \cdot 10^6$ switching cycles at 24 V / 1 A

10.2 Real-time clock

Properties and functions of the clock

This table lists the properties and functions of the SIMOTION C clock.

Table 10- 15 Properties of the SIMOTION C clock

Properties	C230-2	C240 / C240 PN
Type	Hardware clock (integrated "realtime clock")	
Factory setting upon delivery	DT#1992-01-01-00:00:00	
Backup	Permanently installed accumulator (maintenance-free goldcap)	
Accuracy	Max. deviation per day:	
<ul style="list-style-type: none"> With supply voltage on 0 to 55° C With supply voltage off 25° C -20° C to 70° C 	±9 s	-12 s to +4 s
	±2 s +2 s to -9 s	-1 s to +4 s -9 s to +4 s
Backup time	Typically 4 weeks (at 0 to 25° C)	
Charging time	1 h	

With POWER OFF

The SIMOTION C clock continues to operate after POWER OFF for the battery backup time (excluding software clock). The battery is recharged during POWER ON.

No error message is output if the backup function is defective. With POWER ON, the clock resumes at the time at which POWER OFF occurred.

When the SIMOTION C is reset to the factory setting, the clock is also reset to the "factory setting as delivered".

10.3 Transportation and storage conditions for SIMOTION C

With regard to transportation and storage conditions, the SIMOTION C surpasses the requirements specified in IEC 1131, Part 2. The following conditions apply to modules that are transported and stored in the original packaging.

Table 10- 16 Transportation and storage conditions for SIMOTION C

Type of condition	Permissible range
Free fall	≤ 1 m
Temperature (transport)	From - 40° C to + 70° C
Atmospheric pressure	1,060 to 700 hPa (corresponds to an altitude of up to 3000 m)
Relative humidity (transport)	5% to 95%, without condensation

10.4 Mechanical and climatic environmental conditions for operation of the SIMOTION C

Use conditions

The SIMOTION C is designed for use in a stationary, weather-protected installation.

The SIMOTION C satisfies the operating conditions for Class 3C2 in accordance with DIN EN 60721 3-3 (operating locations with high traffic densities and in the immediate vicinity of industrial equipment with chemical emissions).

The SIMOTION C must not be used in the following locations without additional measures being taken:

- Locations with a high percentage of ionizing radiation
- Locations with severe operating conditions, e.g. due to:
 - Dust accumulation
 - Corrosive vapors or gases
- Installations requiring special monitoring, such as:
 - Elevator installations
 - Electrical installations in highly sensitive areas

An additional measure for the use of the SIMOTION C could be installation in a cabinet, for example.

10.4 Mechanical and climatic environmental conditions for operation of the SIMOTION C

Climatic environmental conditions

The SIMOTION C may be used under the following climatic environmental conditions:

Table 10- 17 Climatic environmental conditions

Environmental conditions	Range of application	Comments
Temperature: Horizontal mounting: Vertical mounting	From 0 to 55° C From 0 to 40° C	-
Relative humidity	From 5% to 95%	Without condensation, corresponds to relative humidity (RH) severity level 2 in accordance with IEC 1131-2
Atmospheric pressure	1,060 to 700 hPa	Corresponds to an altitude of mean sea level to 3,000 m
Contaminant concentration	SO ₂ : < 0.5 ppm; Relative humidity <60%, no condensation H ₂ S: < 0.1 ppm; Relative humidity <60%, no condensation	Test: 10 ppm; 4 days 1 ppm; 4 days
Moisture condensation and ice formation	Not permitted	

Mechanical environmental conditions

The mechanical environmental conditions for the SIMOTION C are specified in the following table in terms of sinusoidal vibrations.

Table 10- 18 Mechanical environmental conditions

Mechanical environmental conditions	Operation	Transport (in packaging)
Vibration tested in accordance with DIN EN 60068-2-68	10 to 58 Hz: 0.35 mm 58 to 200 Hz: 50 m/s ²	5 to 9 Hz: 3.5 mm 9 to 200 Hz: 10 m/s ²
Shock resistance tested in accordance with DIN EN 60068-2-27	10 g peak value, 6 ms duration 100 shocks in each of the 3 axes vertical to one another	10 g peak value, 6 ms duration 100 shocks in each of the 3 axes vertical to one another

Reduction of vibration

If the SIMOTION C is subjected to greater shocks or vibrations, you must take appropriate measures to reduce the acceleration or the amplitude.
Installation on damping material (e.g. rubber-bonded metals) is recommended.

10.5 Specifications for dielectric tests, safety class and degree of protection

Test Voltages

During the routine test, the insulation resistance is tested at the following test voltage in accordance with IEC 1131 Part 2:

Table 10- 19 Test Voltages

Circuits with rated voltage U_e relative to other circuits or ground	Test voltage
$0 \text{ V} < U_e \leq 50 \text{ V}$	500 VDC

Safety class

Safety class I in accordance with IEC 536 (VDE 0106, Part 1), i.e. a protective-conductor terminal is required on the mounting rail!

Protection against the ingress of foreign matter and water

IP 20 degree of protection in accordance with IEC 529, i. e. protection against contact with standard probes.

Also: Protection against ingress of solid foreign bodies with diameters greater than 12.5 mm.

No special protection against ingress of water.

11.1 Dimension drawing

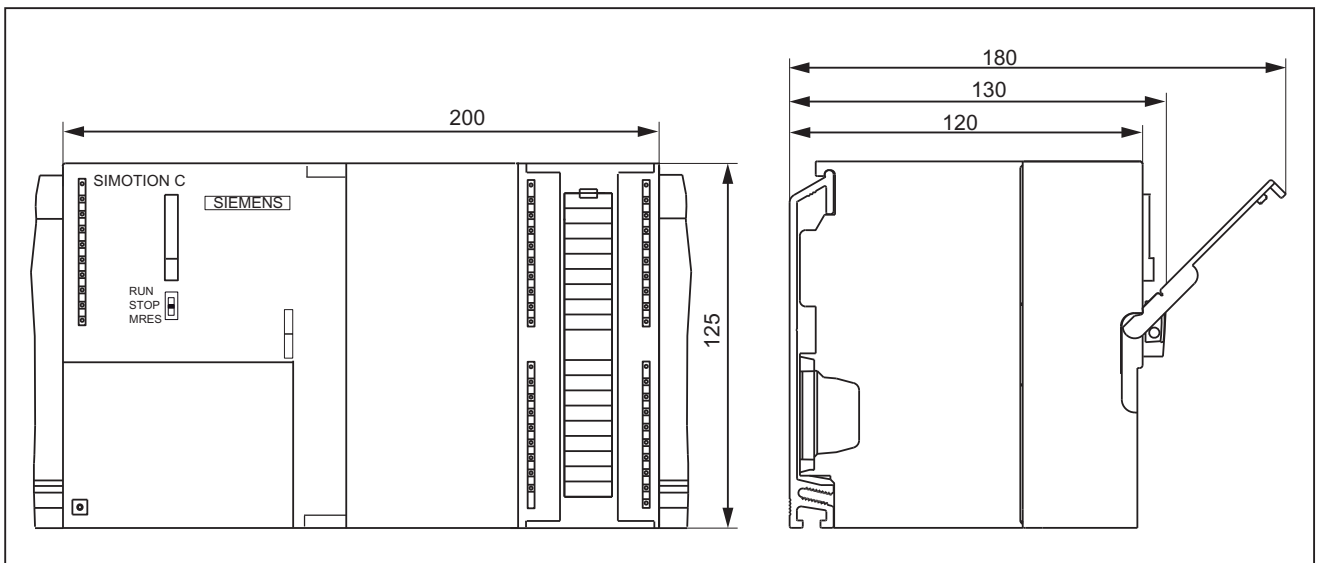

Figure 11-1 SIMOTION C dimension drawing

11.2 Spare parts and accessories

Table 11- 1 Spare parts and accessories

Parts for SIMOTION C	Order number	Accessories	Spare parts
Bus connector	6ES7 390-0AA00-0AA0	-	X
Connecting comb between power supply and SIMOTION C	6ES7 390-7BA00-0AA0	X	-
2 keys for C230-2 (for mode selector)	6ES7 911-0AA00-0AA0	-	X
SIMOTION C230-2 micro memory card	6AU1 700-0AA02-0AA0	X	-
Micro memory card for SIMOTION C240 / C240 PN	6AU1 720-1KA00-0AA0	X	-
Labeling plate (10 items)	6ES7 392-2XX00-0AA0	-	X
Slot number plate	6ES7 912-0AA00-0AA0	-	X
Front connector, 40-pin <ul style="list-style-type: none"> • Screw-type • Spring-tension type 	6ES7 392-1AM00-0AA0 6ES7 392-1BM01-0AA0	X	-
Shield connecting element	6ES7 390-5AA00-0AA0	X	-
Shield connection terminals for <ul style="list-style-type: none"> • 2 cables, each with 2 to 6 mm shield diameter • 1 cable with 3 to 8 mm shield diameter • 1 cable with 4 to 13 mm shield diameter 	6ES7 390-5AB00-0AA0 6ES7 390-5BA00-0AA0 6ES7 390-5CA00-0AA0	X	-

Standards, Certificates and Approvals

A

A.1 General rules

CE marking

	<p>Our products satisfy the requirements and protection objectives of the EC Directives and comply with the harmonized European standards (EN).</p>
---	---

Electromagnetic compatibility

Standards for EMC are satisfied, if the EMC Installation Guideline is observed.

SIMOTION products are designed for industrial use in accordance with product standard DIN EN 61800-3, Category C2.

cULus Approval

	<p>Listed component mark for United States and the Canada Underwriters Laboratories (UL) according to Standard UL 508, File E164110, File E115352, File E85972.</p>
---	---

EMC

USA	
<p>Federal Communications Commission Radio Frequency Interference Statement</p>	<p>This equipment has been tested and found to comply with the limits for a Class A digital device, pursuant to Part 15 of the FCC Rules. These limits are designed to provide reasonable protection against harmful interference when the equipment is operated in a commercial environment. This equipment generates, uses, and can radiate radio frequency energy and, if not installed and used in accordance with the instruction manual, may cause harmful interference to radio communications. Operation of this equipment in a residential area is likely to cause harmful interference in which case the user will be required to correct the interference at his own expense.</p>
<p>Shielded Cables</p>	<p>Shielded cables must be used with this equipment to maintain compliance with FCC regulations.</p>

A.1 General rules

USA	
Modifications	Changes or modifications not expressly approved by the manufacturer could void the user's authority to operate the equipment.
Conditions of Operations	This device complies with Part 15 of the FCC Rules. Operation is subject to the following two conditions: (1) this device may not cause harmful interference, and (2) this device must accept any interference received, including interference that may cause undesired operation.

CANADA	
Canadian Notice	This Class B digital apparatus complies with Canadian ICES-003.
Avis Canadien	Cet appareil numérique de la classe B est conforme à la norme NMB-003 du Canada.

SOUTH KOREA	
<p>이 기기는 업무용(A급) 전자파적합기기로서 판매자 또는 사용자는 이 점을 주의하시기 바라며, 가정외의 지역에서 사용하는 것을 목적으로 합니다.</p> <p>For sellers or other user, please keep in mind that this device in an A-grade electromagnetic wave device. This device is intended to be used in areas other than home.</p>	
<p>The EMC limit values to be observed for Korea correspond to the limit values of the EMC product standard for variable-speed electric drives EN 61800-3 of category C2 or the limit value class A, Group 1 to EN55011. By implementing appropriate additional measures, the limit values according to category C2 or limit value class A, Group 1, are observed. For this purpose, additional measures, such as the use of an additional RFI suppression filter (EMC filter) may be necessary. In addition, measures for EMC-compliant configuration of the plant are described in this Manual and/or the Configuration Manual "EMC Installation Guideline". Please note that ultimately it is always the label on the device that provides the decisive information on the compliance with standards.</p>	

Declaration of conformity

The current Declaration of conformity is available on the Internet at Declaration of conformity (<http://support.automation.siemens.com/WW/view/en/10805446/134200>).

General warning information

CAUTION
<p>There is a risk of injury or of damage to assets. In hazardous areas, personal injury or damage to assets can occur if plug-in connections are disconnected during operation. Make sure that your system is always de-energized before disconnecting plug-in connections in hazardous areas.</p>

C-Tick

AUSTRALIA	
	This product meets the requirements of the AS/NZS CISPR 22.

A.2 Safety of electronic controllers

Introduction

The following remarks relate to fundamental criteria and apply irrespective of the type of controller and the manufacturer.

Risk

A higher degree of safety standard applies to all applications and situations where there is a risk of material damage or injury to persons if there is a failure. Special regulations specific to the system apply to such applications. These must be taken into account for configuration of the controller (e.g. VDE 0116 for furnaces).

For electronic controllers with safety responsibility, the measures required for preventing or controlling faults depend on the hazard inherent in the plant. In this respect, the basic measures listed above are no longer adequate once the hazard exceeds a certain potential. Additional measures (e.g. double redundancy, tests, checksums, etc.) for the controller must be implemented and certified (DIN VDE 0801).

The residual risk

When assessing his machine's risk in accordance with the EC Machinery Directive, the machine manufacturer must take into account the following residual risks emanating from the control and drive components:

1. Unintentional movements of driven machine components during commissioning, operation, maintenance, and repairs caused by, for example:
 - Hardware defects and/or software errors in the sensors, controllers, actuators, and connection technology
 - Response times of the controller and drive
 - Operating and/or ambient conditions not within the scope of the specification
 - Parameterization, programming, cabling, and installation errors
 - Use of radio devices / cellular phones in the immediate vicinity of the controller
 - External influences / damage
2. Exceptional temperatures as well as emissions of light, noise, particles, or gas caused by, for example:
 - Component malfunctions
 - Software errors
 - Operating and/or ambient conditions not within the scope of the specification
 - External influences / damage
3. Hazardous shock voltages caused by, for example:
 - Component malfunctions
 - Influence of electrostatic charging
 - Induction of voltages in moving motors
 - Operating and/or ambient conditions not within the scope of the specification
 - Condensation / conductive contamination
 - External influences / damage
4. Electrical, magnetic and electromagnetic fields generated in operation that can pose a risk to people with a pacemaker, implants or metal replacement joints, etc. if they are too close
5. Release of environmental pollutants or emissions as a result of improper operation of the system and/or failure to dispose of components safely and correctly

ESD guidelines

B.1 ESD definition

What does ESD mean?

All electronic modules are equipped with highly integrated modules or components. Because of the technology used, these electronic components are very sensitive to overvoltages and thus to discharge of static electricity.

The acronym **ESD** has become the established designation for such **E**lectrostatic **S**ensitive **D**evices. The **ESD** designation is used internationally to refer to **e**lectrostatic **s**ensitive **d**evices.

Electrostatic sensitive devices are identified by the following symbol:



Figure B-1 Symbol for identification of electrostatic sensitive devices

 CAUTION
Electrostatic sensitive devices can be irreparably damaged by voltages that are far lower than anything a person can perceive. These voltages occur if you touch a component or the electrical connection of a module without having previously discharged any static from your body. Any damage that occurs to a module as a result of overvoltage is generally not recognized immediately and only comes to light after the equipment has been operating for some time.

B.2 Electrostatic charging of individuals

Any person who is not conductively connected to the electrical potential of the environment can accumulate an electrostatic charge.

This figure indicates the maximum electrostatic charges that can accumulate on an operator when he comes into contact with the indicated materials. These values comply with the specifications in IEC 801-2.

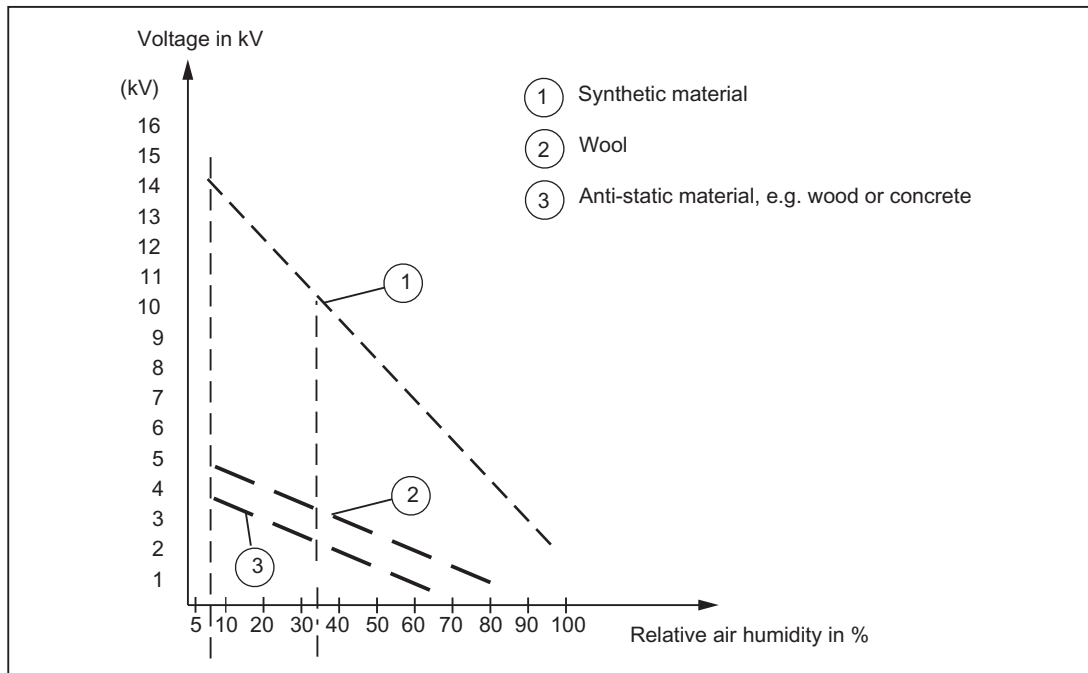

Figure B-2 Electrostatic voltage that can accumulate on operating personnel

B.3 Basic measures for protection against discharge of static electricity

Ensure sufficient grounding

When working with electrostatic sensitive devices, make sure that the you, your workstation, and the packaging are properly grounded. This prevents the accumulation of static electricity.

Avoid direct contact

You should only touch ESD components if unavoidable (for example, during maintenance work). When you touch modules, make sure that you do not touch either the pins on the modules or the printed conductors. If you follow these instructions, electrostatic discharge cannot reach or damage sensitive components.

If you have to take measurements on a module, make sure that you first discharge any static that may have accumulated in your body. To do this, touch a grounded metal object. Only use grounded measuring instruments.

Index

2

2-tier layout, 83

A

Absolute encoder (SSI), 20, 52

Accessories, 184

Actual value, 175

Actual value assignment, 116

Address

Default, 133

Address areas, 172

Technical data, 172

Address assignment

based on module slot, 133

user-assignable, 135

Addresses

analog module, 137

digital module, 136

FM and CP modules, 138

Ambient temperature

permissible, 78

analog module

Addresses, 137

B

Bus connector, 35

Connecting to module, 126

removing, 127

setting the terminating resistor, 126

Bus segment, 123

C

C2xx

Disposal, 6

installation, 162

removal, 162

replacement, 162

wiring diagram - digital inputs/outputs (onboard), 69

C2xx installation, 162

Cable lengths

In subnet, 124

Cables

shielded, 120

CE marking, 185

Characteristic impedance

see terminating resistor, 123

Clearances, 79

Clock, 179

commissioning

System requirements, 143

Components

For PROFIBUS DP subnet, 123, 125

Configuration examples, 65, 75

configuring

electrical design, 92

mechanical structure, 78

Connecting

Bus connector, 126

drive units, 103

Encoder, 114

PG/PC, 144

Power supply, 100

Connecting cable, 99

Ethernet-bus cable, 94

for interface modules, 82

Measuring system cable, 94, 114

PROFIBUS DP cable, 94

Programming device, 94

Setpoint cable, 94

Connection values, 172

cULus Approval, 185

Current consumption

of a central configuration, 93

D

Declaration of conformity, 4, 186

Default address, 133

Degree of protection, 182

IP 20, 182

Design

Configuring, 78

horizontal, 78

vertical, 78

Diagnostics

LED display, 165

Digital input (onboard)

Connecting-up, 117

- Description, 72
 - Technical data, 177
- Digital input/digital output
 - I/O bus, 119
- digital module
 - Addresses, 136
- Digital output (onboard)
 - Description, 75
 - Technical data, 178
 - Wiring, 117
- Dimension drawings, 183
- Dimensions, 172
- DP slave
 - Connections, 123, 172
- DP slave connections
 - Number, 123, 172
- Drive interface
 - as standard output, 51
 - Signals, 47
- Drive- interface, 45
 - Assignment, 46
 - with analog interface, 47
- Drive- interface
 - Stepper drives, 48

E

- Electrical design
 - Configuring, 92
- Electromagnetic compatibility, 185
- EMC directives, 185
- EMC guidelines, 91
- EMERGENCY OFF concept, 91
- Encoder, 52
 - Absolute encoder, 52
 - Connecting, 114
 - Incremental encoder, 52
- Encoder power supply, 52
- Environmental conditions, 180
 - Climatic, 181
 - Mechanical, 181
- ESD guideline, 189
- Ethernet interface
 - Assignment, 37
- Ethernet-subnet, 127
- External electrical interference
 - Protection, 93
- External zero marker, 72, 117, 119

F

- Factory setting, 131
 - Restore, 158
- Field of application, 12
- Filter time, 51, 173
- FM STEPDRIVE
 - Connection, 107
 - installation, 81
- Front connector, 99
- Front panel controls
 - LED displays, 34

G

- Global measuring
 - C240/C240 PN, 73
- Guideline
 - ESD, 189

H

- Highest PROFIBUS-address, 122

I

- I/O modules, 18
- Incremental encoder, 20, 55
- Installation
 - Layout of modules, 81, 82
- Installing, 84
 - Modules, 87
 - Mounting rail, 84
 - Shield connecting element, 121
- Insulation test, 182
- Integrated measurement electronics, 62
- Interface module, 82
 - Connecting cable, 82
- Interface positions, 24, 25, 26
- Interfaces, 35
 - Drive- interface, 45
 - Ethernet interface, 36
 - I/O interface, 68
 - Measuring system interface, 52
 - MPI, 42
 - Power supply connection, 100
 - PROFIBUS DP interface, 42
- IP 20, 182

K

- Kernel update
 - C230-2, 159
 - C240, 161
- Key
 - inserting, 88

L

- Laying rules
 - PROFIBUS cable, 126
- LED display
 - SIMOTION C diagnostics, 165
- LEDs, 165
- Local measuring, 72

M

- Measuring input, 72
- Memory model, 149
- Micro memory card, 32, 33
 - Changing, 145
 - inserting, 145
 - Writing to, 147
- Mode selector, 24, 25, 26
- Module
 - Installing, 87
 - Layout, 81, 82
 - Mounting dimensions, 80
 - Transportation and storage conditions, 179
- Module start address, 134
- Module supply, 100
- Motion control, 20
- Mounting dimensions
 - of the modules, 80
- Mounting rail
 - Installing, 84
 - Length, 80
 - PE connection, 86
- MPI subnet, 131
- MRES, 31

N

- Network components, 125
- Nodes, 122

O

- Onboard drive interface

SIMOTION C

Operating Instructions, 02/2012

- Technical data, 173
- Onboard measuring system interface, 176
- Open equipment, 77
- Overall reset
 - with mode selector, 31
- Overview of connections, 99

P

- PE connection
 - on mounting rail, 86
- PG/PC
 - Connecting, 144
- Power loss
 - of a central configuration, 93
- Power supply, 100
 - Setting supply voltage, 103
- Probe, 117, 119
- PROFIBUS address, 122
 - Highest, 122
 - Rules, 122
- PROFIBUS cable, 125
 - Laying rules, 126
- PROFIBUS device
 - Nodes, 122
- PROFIBUS DP subnet
 - Cable lengths, 124
 - Components, 123, 125
- PROFIBUS subnet
 - Segment, 124
- PROFINET, 39
- Protection against external electrical phenomena, 93
- Protective signal circuits of the stepper motor interface, 49

R

- READY output, 76, 178
- References, 4
- Reliability
 - Risk, 187
- removing C2xx, 162
- Replace module, 163
- replacing C2xx, 162
- Residual risk, 188
- Retaining bracket
 - Shielding terminal, 121
- RUN, 31

S

- Safety class, 182
- Safety of electronic controllers, 187
- Safety regulations, 91
 - EMERGENCY STOP devices, 91
- Segment, 123
 - PROFIBUS subnet, 124
- Setpoint, 175
- Shield connecting element, 120
- Shielding terminal, 120
- SIMODRIVE 611 universal, connection, 104
- SIMODRIVE 611-U, connection, 109
- SIMOTION C memory reset, 154
- Slot number, 88, 133
 - Allocating, 88
 - inserting, 89
- Spare parts, 184
- Standards and approvals, 4
- Stepper drive, 48
 - Signals, 48
- Stepper motor control, 22
 - Position-controlled, 22
- STOP, 31
- STOPU, 31
- Supply voltage, 92
 - Setting, 103
- System clocks, 171
- System integration, 12
 - Components, 15
- System overview, 11

T

- Technical data, 171
- Terminating resistor, 123
 - Adjusting to bus connector, 126
- Test Voltages, 182
- Type plate, 27

U

- UL certification, 185
- Use conditions, 180
- User data
 - Deleting, 157
- User-assignable addressing, 135

V

- Vibration, 181

W

- Weight, 172
- Wiring, 91
 - Front connector, 117
- Wiring diagram, 94
- Writing to
 - Micro memory card, 147