

**SIEMENS**  
*Ingenuity for life*



# SINAMICS S120

The flexible drive system  
for high-performance  
motion control applications

[siemens.com/sinamics-s120](https://www.siemens.com/sinamics-s120)



# SINAMICS S120

The drive family for drive solutions that are fit for the future

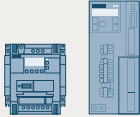
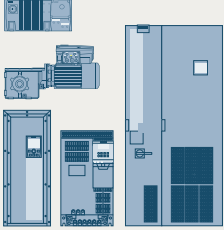

The SINAMICS family offers the optimum drive for each and every drive application – and all of the drives can be engineered, parameterized, commissioned and operated in a standard way.

## SINAMICS – can tackle any drive application

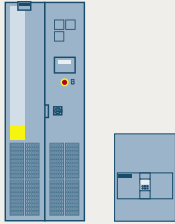
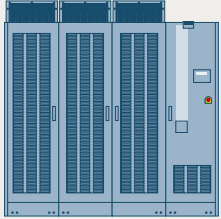
- Wide range of power ratings from 0.12 kW to 85 MW
- Available in low-voltage and medium-voltage versions
- Standard functionality using a common hardware and software platform
- Standard engineering using just two tools for all drives: SIZER for engineering and STARTER for parameterization and commissioning
- High degree of flexibility and combinability

Low voltage AC			DC voltage	Medium voltage AC
Basic Performance	General Performance	High Performance	DC applications	For applications with high power ratings
				
V-series	G-series	S-series	DCM	Medium voltage series
0.12 – 30 kW	0.37 – 6,600 kW	0.12 – 5,700 kW	6 kW – 30 MW	0.15 – 85 MW
When it comes to the hardware as well as the functionality, SINAMICS V converters concentrate on the essentials. This results in a high degree of ruggedness with low associated investment costs.	The functionality of SINAMICS G converters makes them the perfect choice when addressing basic and medium requirements relating to the control dynamic performance.	SINAMICS S converters are predestined for demanding single-axis and multi-axis applications in plant and machinery construction – as well as for the widest range of motion control tasks.	In addition to the highest power ratings, SINAMICS DC converters also offer the maximum degree of availability.	Our seamless and integrated range – which is unique worldwide – encompasses all dynamic response and performance levels in voltage classes 2.3 to 11 kV.

# The best perspectives for a productive future

SINAMICS S120 – versions					
Modular drive system for sophisticated single-/multi-axis applications					
AC/AC drive units for single-axis applications		DC/AC drive units for multi-axis applications			
Blocksize	Chassis	Booksize Compact	Booksize	Chassis	Cabinet Modules
					

## High degree of flexibility for successful machine concepts

As member of the SINAMICS drive family, the modular SINAMICS S120 drive system addresses demanding applications in plant and machinery construction. Single- and multi-axis drives sporting a high dynamic performance with integrated comprehensive functionality and a scalable number of axes can address almost any drive application. SINAMICS S120 facilitates the implementation of flexible and modular machine concepts that can address specific customer requirem

This encompasses:

- Single-axis drives
- Multi-axis drives
- Distributed multi-axis drives with the power unit mounted on the motor to minimize the cabinet size
- Motion control functions are integrated in the drive system (SIMOTION D)

As modular machine designs can be created, you are always in a position to address the demanded range of variants – both now and in the future.

## The answer to complex requirements

Today, machines must be manufactured even more cost-effectively – and should offer end users increasingly higher degrees of productivity. Our SINAMICS S120 drive system addresses both of these goals!

Its sophisticated functionality and high dynamic performance facilitate new and innovative machine concepts and significantly increase production yield. Further, its simple operation and maintenance increase the availability and reduce the lifecycle costs. Summarizing: SINAMICS S120 increases the competitiveness of manufacturers and end users.

## Modularity for machine construction

SINAMICS S120 is flexibly designed to support the modularity demands of machinery construction.

## Applications in machine and plan construction

SINAMICS S120 boosts the performance of your machines – irrespective of whether it involves continuous material webs or clocked and highly dynamic processes:

- Packaging machines
- Plastics machines
- Textile machines
- Printing machines
- Paper machines
- Hoisting gear
- Handling and assembly systems
- Machine tools
- Rolling mills
- Test stands

# Modular portfolio from the Control Unit to the cabling

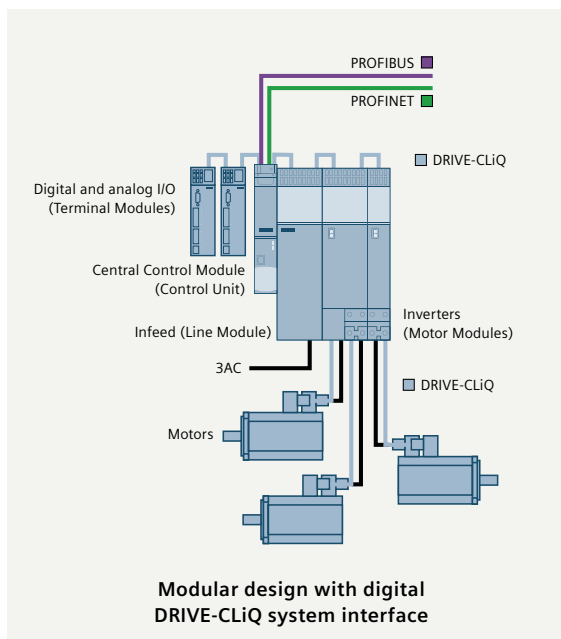

## Modular drive configuration SINAMICS S120 DC/AC-Drives

- One Control Unit with the complete drive intelligence (including the interface to higher-level controls or HMI devices)
- A Line Module (infeed converter) to provide the DC link voltage from the three-phase line supply
- One or several Motor Modules to control the motors
- Optional I/O modules to connect encoders and drive-related inputs and outputs
- Simple wiring using DRIVE-CLiQ
- All interfaces communicate using preconfigured cables
- Drive components are detected using electronic type plates
- Motor Modules and Line Modules in the Booksize Compact, Booksize and Chassis formats

### Flexibility and scalability as a result of the modular design

DC/AC devices set themselves apart as a result of the modular design. The complete drive intelligence is embedded in the Control Units (CU). They handle all of the closed-loop control functions in the drive lineup.

Further, they execute all of the other drive functions, for example logically combining drive-related I/O, positioning functions etc. – and have PROFIBUS DP or PROFINET as central interfaces to connect to higher-level automation systems.

SIMOTION D or SINUMERIK can be used as special Control Units for motion control or CNC applications respectively. SIMOTION D devices are modular Control Units that also have an integrated motion control system in addition to the closed-loop drive control. SINUMERIK devices are modular Control Units to automate machine tools.

Line Modules supply the central DC link to which the Motor Modules (power units) are connected. Depending on the selected Line Module type, energy can be fed back into the three-phase line supply, the DC link voltage can be controlled and line harmonics reduced.

Energy is exchanged between motoring and generating Motor Modules via the central DC link. Only the missing or excess energy is drawn from or injected back into the line supply – or is dissipated in braking resistors. Drive-related inputs/outputs can be expanded using Terminal Modules.

Drive systems in the Booksize-Compact format facilitate an especially compact design. Further, double axis modules allow the width of Booksize-Compact and Booksize devices to be reduced.

# Intelligent products for more drive



CU320-2  
Control Unit

SIMOTION D4x5  
Control Unit

SINUMERIK NCU 7  
Control Unit

I/O modules  
(TM31, TM54F)

## Control Unit modules

Control Unit (CU) modules represent the central intelligence of an S120 drive system. In addition to the basic functions – such as operating system, communication and closed-loop control – they also include the user configuration.

A distinction is made between the following versions:

- **CU320-2 Control Unit:**  
The control module for several drives
- **SIMOTION D4x5-2:**  
Motion control for coordinated operation of several drives
- **SINUMERIK NCU 7x0.3 PN:**  
The CNC control system for the medium and upper performance range

## I/O modules

In addition to the I/O of the CU modules, the I/O modules represent the interface of the drive system to the plant.

The following are available:

- Binary inputs and outputs, also fail safe
- Relay outputs
- Analog inputs and outputs
- Fast inputs/outputs, e.g. for cam sequencers
- Modules to connect motor and machine encoders without DRIVE-CLiQ interface
- Temperature evaluation (KTY84-130 or PTC)

## DRIVE-CLiQ digital interface:

### Low wiring costs

The components of the S120 drive system communicate via the DRIVE-CLiQ system interface.

Essential features:

- They connect Motor Modules, I/O modules etc. with the CUU
- They connect motor encoders, where relevant with electronic type plates for encoder and motor as well as machine encoder
- Simple wiring using a plug-in system based on the RJ45 standard.

Product variance can be reduced and stock inventory costs minimized as a result of the standard cable and plug connector systems used. Not only this, commissioning time and costs are reduced as a result of the lower amount of work required.

# The smart line infeed



Overview of SINAMICS Line Modules

## Basic Line Modules

Our Basic Line Modules are used for applications where energy must only be taken from the line supply. If an excessive amount of energy is regenerated, then this must be dissipated in a braking resistor using a braking module (braking chopper).

### Highlights

- Space-saving
- High degree of efficiency
- For applications without or only a low level of excessive braking energy

## Smart Line Modules

Use our Smart Line Modules if, in addition to drawing energy from the line supply, energy must also be fed back into the line supply. Using an additional braking module with braking resistor, drives can be braked in a specific way even when the power fails.

### Highlights

- Space-saving
- High degree of efficiency
- For applications with excess braking energy

## Active Line Modules

The self-commutated infeed/regenerative feedback units are suitable for motoring as well as generating operation. The Active Line Module can be used for reactive power compensation. Just the same as for a Smart Line Module, it is also possible to use a braking chopper.

### Highlights

- Low line harmonics as a result of the almost sinusoidal line current characteristics
- Controlled DC link voltage, essentially decoupled from the line supply, suitable for high-speed applications, for example cross cutters, even when connected to weak line supplies
- For applications with excess braking energy
- Power factor  $\cos\phi = 1$ , or can be adjusted

Independent of the Line Module type energy is always exchanged between the individual drives through the DC link.

Properties	Basic Line Module	Smart Line Module	Active Line Module
Operating mode	Uncontrolled	Uncontrolled	Controlled (sinusoidal line current drawn)
Line fluctuations	Not compensated	Not compensated	Controlled
Energy recovery	No	Yes	Yes
Harmonics	High	High	Low
Reactive power compensation	No	No	Yes



# Efficient open-loop motor control



## Version and combinability

As power unit, the Motor Modules control the motors with a variable voltage and frequency. They are available in the Booksize Compact, Booksize as well as Chassis formats.

Both versions can be operated on one DC link.

## Cooling

The motor cooling method depends on the power rating and type.

The Booksize Motor Module is usually cooled via internal air cooling. The power loss occurring is dissipated directly into the control cabinet.

The Chassis Motor Modules are either air or liquid-cooled.

The advantages of liquid cooling for high power ratings when compared to air cooling are the smaller mounting footprint and quiet converter operation. It makes sense to use liquid cooling in small and poorly ventilated spaces and harsh environmental conditions (e.g. onboard ships). Liquid cooling facilitates a significantly more efficient heat dissipation, so that it is not necessary to control the climate of rooms. As a consequence, redundant systems can be easily implemented. Liquid cooling is also just as suitable for installations where noise levels are to be kept low (e.g. test equipment).

## Innovation meets continuity – new C-/D-Type Motor Modules in the Booksize format are available:

Compact	Less space required in the control cabinet <ul style="list-style-type: none"> <li>• Reduced weight: New Motor Modules with three-fold overload capacity</li> <li>• Reduced height: New integrated motor plug</li> </ul>
User friendly	Faster and convenient connection of the motor plug
Rugged	Consistent improvement of the shielding concept, the mounting technology, the mounting plate

# Ready-to-connect drive unit for plants and systems that extend over a wide area



Distributed SINAMICS S120M with adapter module and hybrid cable

SINAMICS S120M expands the SINAMICS S120 drive system to include a distributed version. This involves a compact, ready-to-connect drive unit comprising:

- Synchronous servomotor with multturn absolute encoder
- Integrated power unit (Motor Module)

The power unit migrates from the cabinet to the motor and is directly integrated in the driven axis. This provides advantages and flexibility for existing as well as new machine concepts.

## Application areas

Packaging, printing, glass and textile industries include some of the typical SINAMICS S120M applications.

The distributed SINAMICS S120M is ideally suited for:

- Machines that extend over wide areas (long cables)
- Limited cabinet envelope dimensions
- Modular machine concepts with flexible machine layout



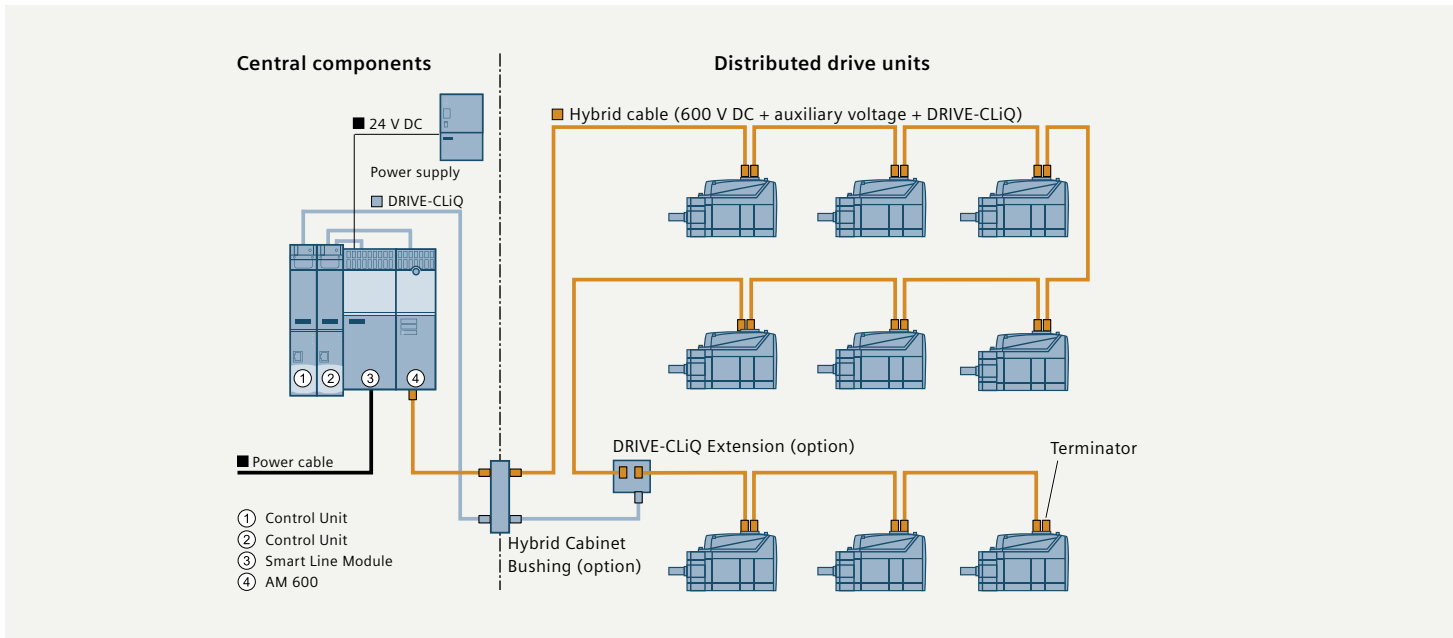

### SINAMICS S120M features

- Up to 12 distributed SINAMICS S120M servo drives can be operated on one adapter module (depending on the power)
- As many adapter modules as required can be operated on an appropriately dimensioned infeed unit
- DI/DOs integrated in the drive for user-friendly adaptation to the machine environment
- With the Terminal Module (TM54F), all of the Safety Integrated functions available in the SINAMICS S120 system are available
- Optimum integration into the SIMOTION and SINUMERIK system landscape

Highlights at a glance	
Description	Your benefits
Motor Module is integrated in the SINAMICS S120M	Smaller cabinet envelope dimensions
Less heat to be dissipated as a result of the distributed topology	Less cabinet climate control
The prefabricated hybrid cable includes all of the signal and power cables	Less time for cabling and shorter cable lengths
The cabinet size is specified for retrofit projects	Increased flexibility for retrofits
SINAMICS S120M is part of the SINAMICS S120 system	All safety and communication versions are available

# Independent single-motor drive with Control Unit and Power Module



Blocksize devices from 0.55 to 132 kW



Chassis device  
110 up to 250 kW

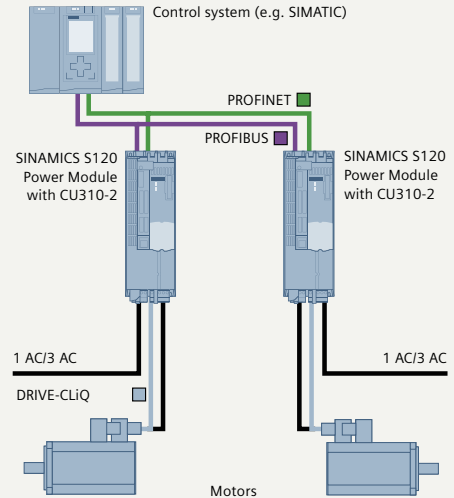

SINAMICS S120 single-axis drive

## AC-Drives for single-axis applications

- An independent single-motor SINAMICS S120 AC-Drive comprises a Control Unit and Power Module
- Alternatively, a Power Module can be integrated into a multi-axis lineup via a CU adapter
- Power Modules are available in the Blocksize and Chassis formats

For single-axis drives, the line feed and the power supply of the motor are combined in one device – the Power Module. For single-axis applications, the closed-loop drive control is handled by a special Control Unit (e.g. CU310-2) mounted on the Power Module; for multi-axis applications, using a Control Unit (e.g. CU 320-2) coupled via DRIVE-CLiQ. In the latter case, instead of the Control Unit, a CU adapter is mounted on the Power Module.

Coupled decentrally via PROFIBUS DP or PROFINET to a higher-level control system, positioning tasks in automatic assembly machines and handling systems can be reliably tackled by SINAMICS S120 AC-Drives.

## Typical application areas

The single-axis drives are suitable for applications in all sectors, for example travel drives, centrifuges, elevators and extruders as well as for mixers and kneaders.

Single-axis SINAMICS S120 AC-Drives are also the ideal solution for multi-axis applications, where the drive axes are located remotely from each other. The same is true for modular machine concepts, which are being increasingly implemented in the packaging and woodworking industry.

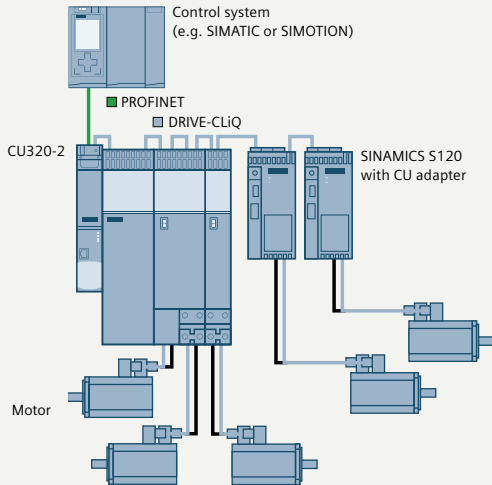

SINAMICS S120 mixed lineup with DRIVE-CLiQ adapter



CU310-2  
Control Unit



SIMOTION D410  
Control Unit



CUA31  
adapter



CUA32  
adapter

### Central control intelligence with interface to the control system: CU310-2 Control Unit

AC-Drives are each equipped with a CU310-2 Control Unit for coupling to a higher-level control. It offers functions from a basic speed controller up to extensive positioning functions.

CU310-2 DP with PROFIBUS DP connection or CU310-2 PN with integrated PROFINET interface are available. Drive-related inputs/outputs in the CU can be simply logically combined using BICO technology. As a consequence, the highest possible degree of decoupling between the drive and higher-level control system can be achieved.

For AC-Drives, when required, an additional encoder and drive-related I/O can be connected via DRIVE-CLiQ.

### Motion Control integrated in the drive: SIMOTION D410 Control Unit

The SIMOTION D410 Control Unit is the ideal solution if, beyond the closed-loop control intelligence, motion control is required for an axis and PLC functionality in a compact format. SIMOTION D410 can be used for single-axis applications – such as winders, cross cutters and feed equipment – or also in synchronous groups as is the case for modular machine concepts. The machine module automated with SIMOTION D410 receives the master value from a higher-level control system and synchronizes its axis to this leading value. D410 DP with PROFIBUS DP connection or D410 PN with integrated PROFINET interface can be selected. Up to four fast cam outputs or three probe inputs can be implemented using the onboard inputs/outputs.

### CUA31/32 Control Unit adapter for multi-axis applications with SINAMICS S120 AC-Drive

The drive is connected to a multi-axis Control Unit, e.g. CU320-2, using the CU adapter CUA31 via the DRIVE-CLiQ interface. This Control Unit then handles the drive functions for the AC-Drive.

In this configuration, SINAMICS S120 AC-Drives can also be used in mixed operation with SINAMICS S120 multi-axis devices. This facilitates maximum flexibility when using SINAMICS S120 devices.

In comparison to the CUA31, the CUA32 also has an integrated HTL/TTL encoder interface to connect an external encoder.

# Engineering and handling made easy



SIZER for Siemens Drives tool

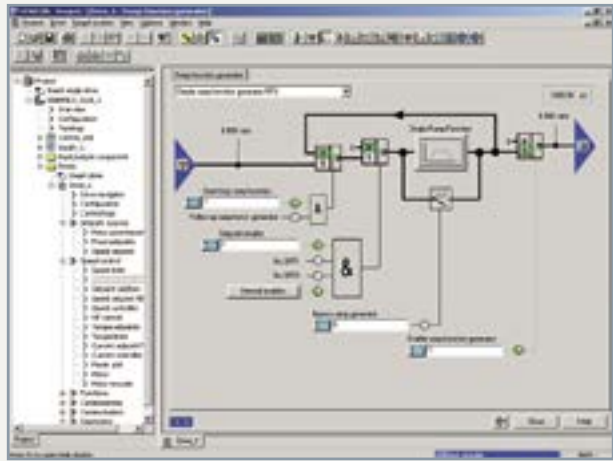

STARTER tool

## Favorably priced – with system-based flexibility

SINAMICS covers the complete range of power ratings with a uniquely integrated and seamless philosophy and operator navigation. This means the following: simple entry into the system, and know-how once gained can be directly applied, e.g. with the higher-level tools for engineering, configuring and commissioning.

## The optimum configuration – quickly and reliably: SIZER for Siemens Drives engineering tool

With SINAMICS, a drive system can be selected and dimensioned as quickly as never before. This is because the SIZER engineering tool includes all of the components that can be used to create a drive system. It allows users to simply and quickly select and dimension a drive. SIZER can be quickly learned and intuitively operated thanks to its graphic interface and the integrated Wizard.

## Speeds up commissioning: STARTER tool

STARTER is the standard commissioning tool for all drives belonging to the SINAMICS family. Commissioning engineers can configure and optimize even complex systems in a very brief period of time as a result of the transparent layout. STARTER is available in three different installation versions: as stand-alone version, integrated in Drive ES for applications with SIMATIC or integrated in SCOUT for applications with SIMOTION.

## Fast and automatic: electronic type plate

The electronic type plates in every component are an important element when digitally linking the SINAMICS S120 drive system. They can be used to automatically identify all of the drive components via the DRIVE-CLiQ interface. This means that when commissioning or replacing components, data does not have to be manually entered – and commissioning becomes even more reliable. For example, electrical equivalent circuit diagram and integrated motor encoder parameters are saved in the electronic type plates of the motors. The type plates also include information such as the article and identification numbers.

## Made easy: Engineering and handling

- All of the drive components are very easily connected using the prefabricated DRIVE-CLiQ cables
- Automatic parameterization of the drive configuration using electronic type plates
- Fast and reliable drive selection and dimensioning using the SIZER engineering tool
- User-friendly commissioning using the STARTER commissioning tool

# Integrated web server for efficient diagnostics and maintenance – at any time, at any location



The SINAMICS drive system with integrated web server is expanded to include efficient diagnostic and maintenance options. It is an integral component of the SINAMICS firmware. Every PC capable of going on the Internet and with a browser is sufficient to execute functions, for example

- Download a configuration
- Update the firmware
- Provide a status overview of the drive
- Evaluate alarms and fault messages
- Monitor and adapt parameter settings
- Save machine documentation, including notes
- Create user administration for access protection

Many new options relating to drive diagnostics and remote maintenance can be obtained based on the web server.

## SINAMICS web server uses

The integrated web server is ideal for applications where the STARTER commissioning software and version interdependencies are not desirable. Series commissioning is also possible without STARTER.

Local and remote diagnostics and maintenance are straightforward, taking into account the appropriate security measures (e.g. firewall). A current Internet browser is sufficient for obtaining access.

[www.siemens.com/sinamics-webserver](http://www.siemens.com/sinamics-webserver)

## Efficient diagnostics and maintenance – highlights of the SINAMICS web server

- Shorter machine downtimes through efficient diagnostics and maintenance
- You can directly toggle between German, English and Chinese
- Included as standard in the firmware – no additional costs
- Can be accessed via all LAN and PROFINET interfaces
- Two users with different authorization levels can be configured, e.g. for operating and service personnel

# Positioning, synchronous operation and adaptation

To a wide range of applications is made easy,  
including securing the corresponding know-how

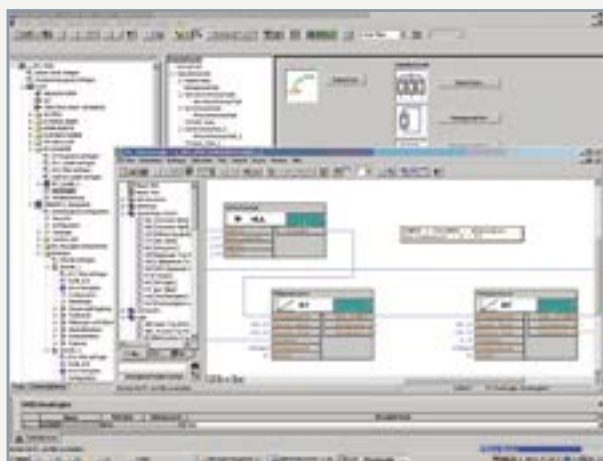

Graphic parameterization with DCC

## Drive Control Charts (DCC): optimum adaptation to the drive task

Drive Control Charts provide the option of freely configuring technological functions for the SINAMICS S120 drive system very simply in STARTER. As a consequence, users have a new dimension when it comes to individually adapting the system to address the specific drive tasks of their particular machine. Drive Control Charts (DCC) are control, arithmetic and logic blocks that are available in a drive control block (DCB) that can be used to configure specific functions. Using the DCC Editor, multi-instance-capable blocks can be linked by dragging and dropping to create open-loop and closed-loop control functions.

## Extending Drive Control Blocks (DCB)

DCB Extension is an extension of the block scope, which can be used as additional, autonomous library in the DCC Editor. DCB Extension involves new motion control blocks that are available in the form of a motion control library.

Using these blocks, the following positioning and synchronous functions can be implemented with DCC in the SINAMICS S120 drive system:

- Positioning
- 1:1 synchronous operation
- Gearing
- Gearing and positioning
- Camming

Further, with DCB Extension there is the possibility of creating user-specific blocks.

## Drive Control Charts / Drive Control Block Extension – the highlights

Drive-related open-loop and closed-loop control tasks can be shifted from the control into the drive.

- Relieving higher-level control systems
- Lower costs when implementing machine sequences
- Increased machine performance
- Simpler implementation of modular machine concepts
- Implementation of positioning and synchronous operation functions
- User-friendly graphic programming using the DCC Editor
- Linking multi-instance-capable blocks by dragging and dropping
- Test and diagnostic functions to verify program behavior and fault diagnostics



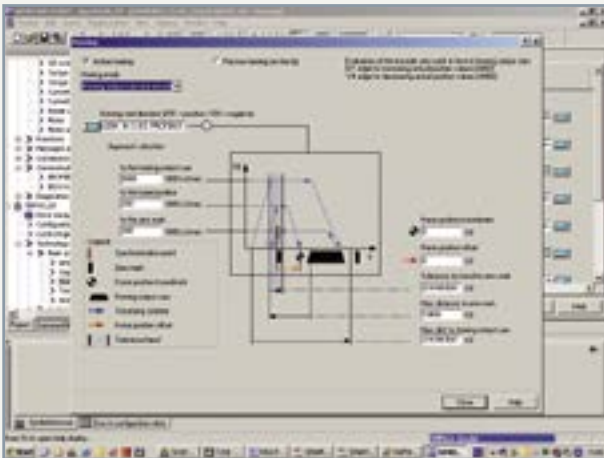

Parameterizing screen form for EPos

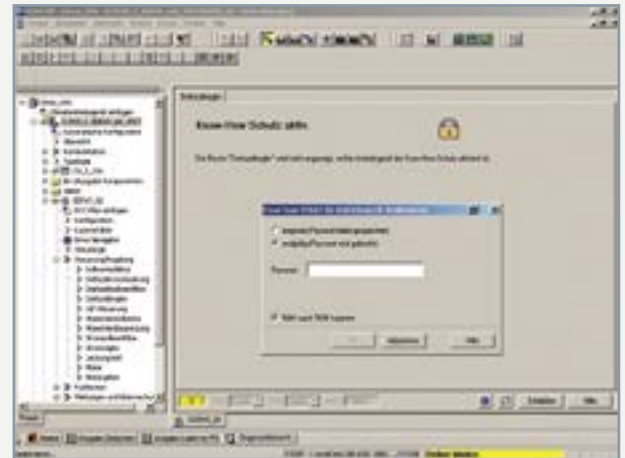

Parameterizing screen form with active know-how protection

### EPos – integrated positioning functions

With the integrated EPos positioning functions, an additional higher-level control is not required for many positioning applications. Further, this integrated functionality is also extremely flexible: It can be used for servo control with a high dynamic performance – as well as for more basic applications with vector-controlled induction motors. When commissioning, up to 64 target positions or travel paths as well as the associated travel velocities can be permanently saved in the drive. Positioning can be specified to either be absolute or relative.

Further, it is also possible to transfer these parameters from a higher-level PLC as required. It is even possible to change the target positions and velocities on the fly when positioning.

### SINAMICS Know-how protection

The SINAMICS drive family has been expanded to include know-how protection. This is an efficient and unique function to safely protect your engineering investment. The know-how protection is directly activated at the converter, and is password-protected. When know-how protection is active, all of the parameter settings are hidden and locked so that they cannot be accessed by a third party. The OEM can individually declare everything that should be freely accessible in the form of a “Don’t hide list” for everything that is required to use the machine function.

It provides protection against:

- Accessing engineering data
- Unauthorized copying
- Manipulation

This protects your ideas and engineering know-how and therefore your investments.

When copy protection is activated, the serial numbers of the (target) memory card and Control Units are also incorporated in the protection.

As a consequence, the parameterization can only be used on the specified hardware.

### SINAMICS know-how protection – the highlights

- Integral component of the SINAMICS firmware
- Can be combined with copy protection
- A know-how-protected CF card can also be created offline (without CU) just using STARTER
- An exception list with freely accessible parameters can be defined, e.g. for operating and service personnel

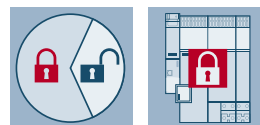

# Integrated safety to protect persons and machines



Safety-related communication via PROFIBUS with PROFI-safe profile

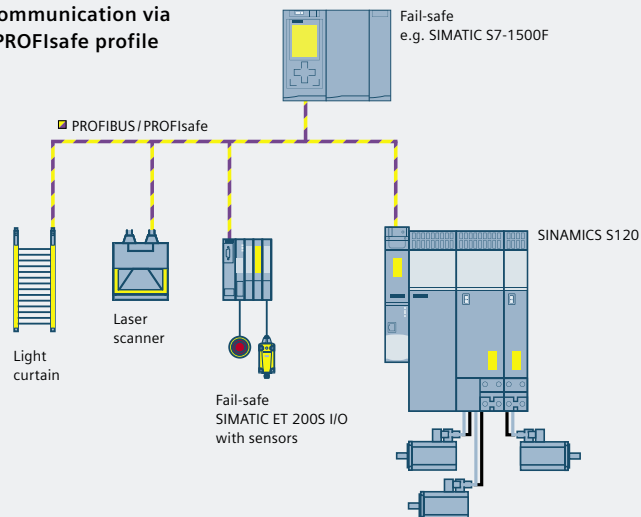

Configuration example: SINAMICS S120 Booksize with integrated safety functions connected to a fail-safe SIMATIC S7-300F control

## Safety Integrated functions to simply implement safety concepts

The integrated safety functions are suitable for plants and machines where flexible safety functions are required. These support the creation of customized concepts.

As standard, SINAMICS S120 provides the following Safety Integrated functions:

- **Safe Torque Off (STO):**  
This function ensures that a motor can no longer develop a torque, therefore preventing undesirable starting.
- **Safe Stop 1 (SS1):**  
This function quickly stops a motor and once the motor has come to a standstill, switches it into a no-torque condition by activating STO.
- **Safe Brake Control (SBC):**  
This function is used to safely control a holding brake.

The following Safety Integrated functions are optionally available; these are released using a license:

- **Safe Stop 2 (SS2):**  
This function quickly stops a motor and after it has come to a standstill, it monitors the standstill position.
- **Safe operating stop (SOS, Safe Operating Stop):**  
This function safely monitors standstill without deactivating the closed-loop drive control.

## Safely-Limited Speed (SLS):

This function monitors that the drive does not exceed a preset speed or velocity limit.

- **Safe Direction (SDI):**  
This function ensures that the drive can only rotate in the selected direction.
- **Safe speed monitoring (SSM):**  
Signals if a drive is operating below a speed or velocity limit that can be set.
- **Safely-Limited Position (SLP):**  
This function monitors that the axis moves in a defined traversing range.
- **Safe Brake Test (SBT):**  
This function safely tests the function of the brake.
- **Safe Position (SP):**  
This function transfers the safely determined position actual value in the drive to a safety-relevant control via the safety-relevant PROFI-safe.

SINAMICS safety solutions are certified according to IEC 61508 SIL 2 and EN ISO 13849-1, PL d and Category 3. The safety functions are either controlled via safety input terminals, which are either on the Control Unit or the Terminal Module TM54F. Control is possible via PROFIBUS and PROFINET with PROFI-safe when the drive is integrated in a complete automation solution.

# PROFINET-based communication that is fit for the future



## **PROFINET:** for more performance and open IT communication

SINAMICS S120 is also available with a PROFINET interface. This Ethernet-based bus allows control data to be quickly exchanged and means that SINAMICS S120 drives can even be used in the highest performance multi-axis applications. PROFINET simultaneously transmits, for example, operating and diagnostics data to higher-level systems using standard IT mechanisms (TCP/IP). This means that it can be simply integrated into an IT factory environment.

## **PROFIBUS:** the established, universal fieldbus

SINAMICS S120 supports, as standard, PROFIBUS DP – the standard fieldbus within Totally Integrated Automation. It ensures powerful and seamless communications between all of the components involved in the automation solution: HMI (operator control and visualization), control, drives and I/O

## **PROFIdrive:** drive interface for PROFINET

For PROFINET and PROFIBUS, the functional interface between the control and the drives is defined by the PROFIdrive drive profile from PROFIBUS International (PI). PROFIdrive is specified by the PI User Organization and is established through Standard IEC 61800-7 as the standard that is fit for the future. PROFINET users who are already operating drives connected to PROFIBUS profit from this. A user program does not have to be changed when making a transition from PROFIBUS to PROFINET. PROFIdrive defines the device behavior and the way internal device data is accessed for electric drives connected to PROFIBUS and PROFINET – from basic drive converters up to high-performance servo controllers.

# Sets productivity standards

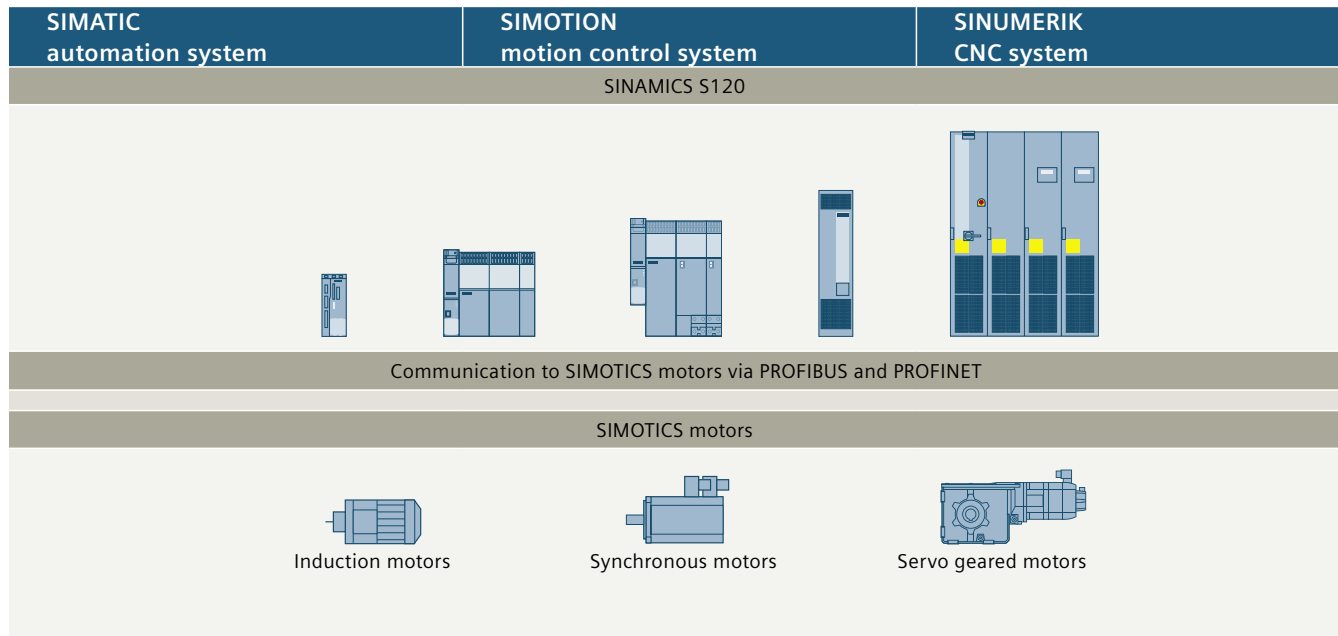

## Totally Integrated Automation with SINAMICS S120

- TIA: seamless and integrated sector-specific automation solutions
- PROFIBUS and PROFINET are integral components of TIA
- Motion control with SIMOTION
- Numeric control with SINUMERIK

## Easy and straightforward:

### Totally Integrated Automation with SINAMICS S120

In addition to SIMATIC, SIMOTION and SINUMERIK, SINAMICS also belongs to the core components of TIA. The STARTER commissioning tool is also an integrated component of the TIA platform. All automation solution components can be parameterized, programmed and commissioned with a seamless and integrated engineering platform without transition to another system. The seamless and integrated data management ensures consistent data and simple archiving of the complete plant or system project.

## The basis for customized automation solutions

With Totally Integrated Automation (TIA), Siemens is the only supplier that can provide a seamless and integrated range of products and systems for all sectors from a single source. Coordinated to the individual customer requirements, based on Totally Integrated Automation (TIA) efficient, sector-specific automation solutions can be implemented. Lower lifecycle costs when operating plants and systems and a significant reduction of the time-to-market result in significant increases in productivity and higher investment security.

# For higher efficiency, reliability and productivity

## Triple integration creates a true added value

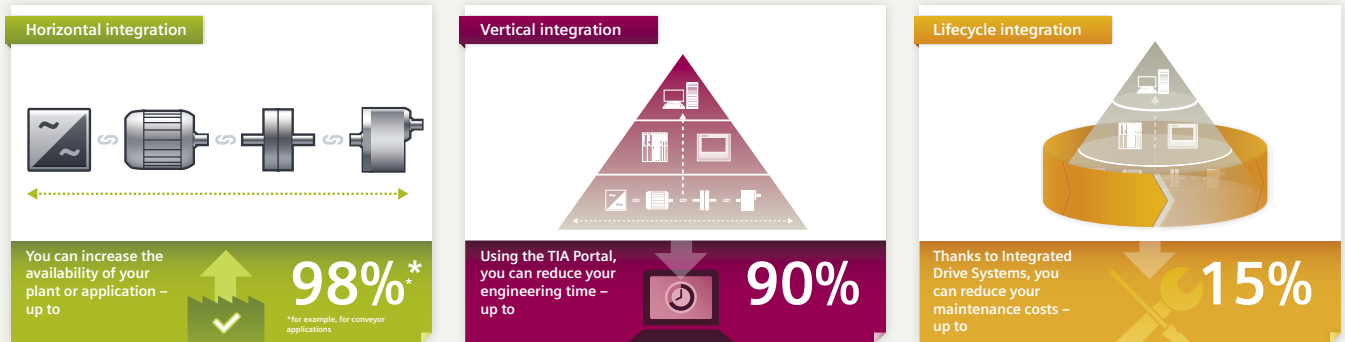

### Horizontal integration

The integrated drive portfolio: All converters, motors, couplings and gearboxes are available from a single source. Perfectly integrated, perfect interoperability. For all power and performance classes. As standard solution or as completely customized solution.

#### Your advantages

- Unique product range from a single source
- Guaranteed compatibility of the drive train
- Reliable system performance

### Vertical integration

Integrated in the automation technology: from the field through the controller level up to the manufacturing execution system (MES) thanks to Totally Integrated Automation. For each and every application.

#### Your advantages

- The drive train as integral component of Totally Integrated Automation (TIA)
- Intelligent monitoring and open-loop control
- Perfect interaction between the automation components and the open-loop control, sensors, user interfaces and communication

### Lifecycle integration

Integrated software and services over the complete lifecycle: extensive software tools and competent service for the complete lifecycle, from planning through engineering the application up to service. For higher performance and maximum investment security.

#### Your advantages

- The configuration – from the coupling up to the Control Unit – optimizes the efficiency
- Engineering tools from the design up to commissioning – for a shorter time to market
- Productivity proven through simulation already in the early development phase
- Outstanding product, lifecycle and sector know-how

# The optimum solution for each and every drive task

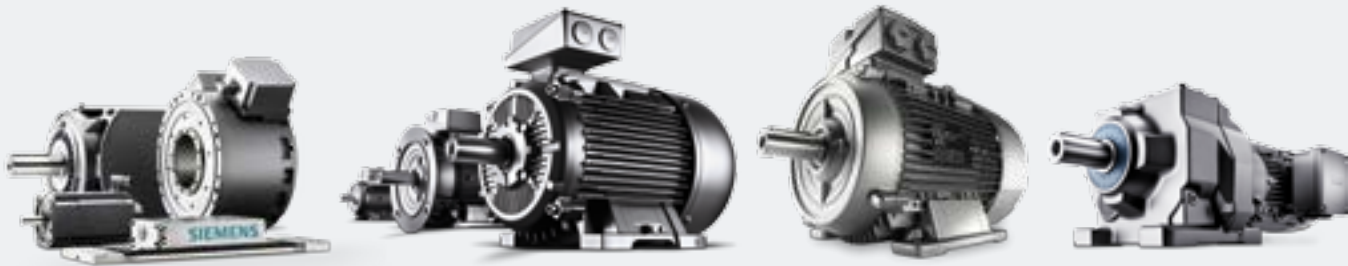

## The drive solution that offers everything

The wide range of functions and the different versions make SINAMICS S120 the universal drive solution for machinery construction.

A broad range of motors and control systems optimally tailored to address the various applications permits fully integrated solutions – simple to design, commission and operate. The motors are connected to the power units through prefabricated Motion Connect power and data cables.

Electronic type plates in the motors guarantee reliable auto-parameterization of the drive lineup. In operation, the encoder values are transferred to the drive line-up in the controller clock cycle via the DRIVE-CLiQ interface.

The drive is connected to the automation system via the PROFINET, PROFIBUS DP or CANopen fieldbuses.

[siemens.com/simotics](https://www.siemens.com/simotics)

## Synchronous and induction motors can be operated

Synchronous as well as induction motors can be operated with SINAMICS S120. In addition to its range of SIMOTICS low-voltage motors, Siemens also has a wide range of different motor types specifically designed for motion control applications:

- SIMOTICS low-voltage motors as standard and trans-standard motors or explosion-protected versions for almost all sectors
- SIMOGEAR geared motors
- SIMOTICS reluctance motors: economically the right choice for energy efficiency and dynamic, e.g. for winders, extruders and servo pumps
- SIMOTICS S servomotors, optionally equipped with various gearbox types, for high-speed positioning tasks, clocked axes and feed drives
- SIMOTICS M main motors for high-speed, high-precision rotary axes, e.g. for winding and synchronous operation applications – as well as main spindles in machine tools
- SIMOTICS L linear motors for positioning and feed axes demanding the highest dynamic performance
- SIMOTICS T torque motors, which are directly mounted to the driven machine component demanding the highest dynamic performance



# Modular and fit for the future



## SINAMICS S120 in machinery construction

**SINAMICS S120 and SIMOTION:** In machinery construction, increasingly complex motion control tasks must be mastered, which must always run faster and with a higher precision. Here, the SIMOTION motion control system and the SINAMICS S120 high-performance drive system form a perfect team.

**SINAMICS S120 and SINUMERIK:** SINUMERIK solution line and SINAMICS S120 form the ideal system platform for machinery construction. Thanks to the scalable hardware and software, SINUMERIK solution line provides you with almost unlimited application possibilities.

### Advantages

- Positioning tasks and basic, drive-related closed-loop control functions are engineered using the integrated EPos and DCC functions
- Motion control applications are engineered using SIMOTION or SIMATIC T-CPU
- Processing machines are engineered using SINUMERIK solution line

## SINAMICS S120 in plant construction

The SINAMICS S120 concept allows fast and simple mechanical and electrical integration into the plant or system, therefore reducing engineering costs as well as engineering risks. Based on a comprehensive range of options, the drive system can be flexibly adapted to plant/system-specific requirements.

### Advantages

- Flexible development of drive versions
- Scalable power and performance
- Ready-to-connect Cabinet Modules
- Chassis units for integration in a cabinet
- Low costs for training, engineering and commissioning
- Simple to replace, spare parts inventory, logistics
- Low lifecycle costs through energy-saving and low maintenance costs
- Highest possible security of investment

# Technical data

## Components and advantages at a glance:



- **Control modules** (Control Units) process cross drive and axis functions, and are the central link to higher-level controls
  - **Motor Modules** operate as inverter, and supply the connected motors
  - **Line Modules** feed the central power into the DC link, regenerate into the line supply and compensate line fluctuations
  - **Power Modules** for AC-Drives combine the power infeed and the power unit to create a device that is ready to switch on
  - **Electronic options** extend the functionality and represent various interfaces to encoders and process signals
  - **DC link components** are used to stabilize the DC link voltage
  - **Line-side power components** such as fuses, contactors, reactors and filters round off the system
- Dynamic and precise: 32-bit technology
  - Fast: short current rise time
  - Universal: for synchronous and induction motors
  - Rugged: high overload factor
  - Safe: Safety Integrated
  - Flexible and simple: BICO technology
  - Plug & play: DRIVE-CLiQ makes it possible
  - Customized: Drive Control Chart

## SINAMICS S120 integrated safety functions

STO	Safe Torque Off
SBC	Safe Brake Control
SS1	Safe Stop 1 (Safe shutdown, stop Category 1)
SOS	Safe Operating Stop
SS2	Safe Stop 2 (Safe shutdown, stop Category 2)
SLS	Safely-Limited Speed
SSM	Safe Speed Monitor
SDI	Safe Direction
SLP	Safely-Limited Position
SP	Safe Position
SBT	Safe Brake Test

<b>Drive type</b>
<b>Degree of protection</b>
<b>Line voltage <math>U_{line}</math>/power ranges</b>
1 AC/3 AC 200 ... 240 V
3 AC 380 ... 480V
3 AC 500 ... 690V
<b>Power infeed</b>
<b>Energy recovery</b>
<b>Line frequency</b>
<b>Output voltage</b>
<b>Output frequency</b>
U/f control
Vector control
Servo control
<b>Control technique</b>
U/f control
Vector control with/without encoder
Servo control with/without encoder
<b>Motors</b>
Induction motors
Servomotors
Main motors
Linear motors
Torque motors
<b>Control dynamic performance</b>
Vector control
• Rise time closed-loop speed control
• Rise time closed-loop torque control
Servo control
• Rise time closed-loop speed control
• Rise time closed-loop torque control
<b>Technological functions</b>
<b>Safety functions</b>
<b>Interfaces</b>
<b>Tools</b>
<b>Typical applications</b>
<b>Catalog</b>

## S120 – modular drive system for demanding single-axis/multi-axis applications

Blocksize	Chassis	Booksize Compact	Booksize	Chassis	Cabinet Modules
					
AC/AC device modular	AC/AC device modular	DC/AC system modular	DC/AC system modular	DC/AC system modular	DC/AC system modular
IP20	IP20	IP20	IP20	IP00/IP20	IP20 (IP21/IP23/IP54)
0.55 kW ... 4 kW/ 0.55 kW ... 55 kW	–	–	–	–	–
0.55 kW ... 132 kW	110 ... 250 kW	1.6 ... 9.7 kW	1.6 ... 107 kW	110 ... 800 kW / 3000 kW <sup>2</sup>	4.8 ... 800 kW / 3000 kW <sup>2</sup>
11 kW ... 132 kW	–	–	–	75 ... 1500 kW / 5700 kW <sup>2,3</sup>	75 ... 1200 kW / 4500 kW <sup>2</sup>
Uncontrolled	Uncontrolled	Uncontrolled	Optionally uncontrolled or controlled		
No	No	Yes	Yes, for Smart and Active Line infeed		
47 ... 63 Hz	47 ... 63 Hz	47 ... 63 Hz	47 ... 63 Hz	47 ... 63 Hz	47 ... 63 Hz
0 ... 0.95 x U <sub>line</sub>	0 ... 0.97 x U <sub>line</sub>	0 ... U <sub>line</sub>	0 ... U <sub>line</sub>	0 ... U <sub>line</sub>	0 ... U <sub>line</sub>
0 ... 400 Hz <sup>1</sup>	0 ... 200 Hz <sup>1</sup>	0 ... 550 Hz <sup>1,3</sup>	0 ... 550 Hz <sup>1,3</sup>	0 ... 200 Hz <sup>1</sup>	0 ... 200 Hz <sup>1</sup>
0 ... 300 Hz <sup>1</sup>	0 ... 160 Hz <sup>1</sup>	0 ... 300 Hz <sup>1</sup>	0 ... 300 Hz <sup>1</sup>	0 ... 160 Hz <sup>1</sup>	0 ... 160 Hz <sup>1</sup>
0 ... 550 Hz <sup>1,3</sup>	0 ... 330 Hz <sup>1</sup>	0 ... 550 Hz <sup>1,3</sup>	0 ... 550 Hz <sup>1,3</sup>	0 ... 330 Hz <sup>1</sup>	0 ... 330 Hz <sup>1</sup>
Yes	Yes	Yes	Yes	Yes	Yes
Yes	Yes	Yes	Yes	Yes	Yes
Yes	Yes	Yes	Yes	Yes	Yes
Yes	Yes	Yes	Yes	Yes	Yes
Yes	Yes	Yes	Yes	Yes	Yes
Yes	Yes	Yes	Yes	Yes	Yes
Yes	Yes	Yes	Yes	Yes	Yes
8 ... 10 ms <sup>1</sup>	11 ... 15 ms <sup>1</sup>	8 ... 10 ms <sup>1</sup>	8 ... 10 ms <sup>1</sup>	11 ... 15 ms <sup>1</sup>	11 ... 15 ms <sup>1</sup>
1 ... 2 ms <sup>1</sup>	2 ... 3 ms <sup>1</sup>	1 ... 2 ms <sup>1</sup>	1 ... 2 ms <sup>1</sup>	2 ... 3 ms <sup>1</sup>	2 ... 3 ms <sup>1</sup>
2 ... 3 ms <sup>1</sup>	5 ... 7 ms <sup>1</sup>	2 ... 3 ms <sup>1</sup>	2 ... 3 ms <sup>1</sup>	5 ... 7 ms <sup>1</sup>	5 ... 7 ms <sup>1</sup>
0.5 ... 1 ms <sup>1</sup>	1 ... 2 ms <sup>1</sup>	0.5 ... 1 ms <sup>1</sup>	0.5 ... 1 ms <sup>1</sup>	1 ... 2 ms <sup>1</sup>	1 ... 2 ms <sup>1</sup>
Flying restart circuit, automatic restart, kinetic buffering, basic positioner, BICO technology, freely configurable blocks (Drive Control Chart), technology controller, motion control (in conjunction with SIMOTION), numeric control with SINUMERIK solution line					
STO, SBC, SS1, SOS, SS2, SLS, SDI, SLP, SSM, SP, SBT					
Digital, analog, serial (RS 232 / RS 485), PROFIBUS DP, PROFINET, CANopen (In conjunction with CU320-2)					
SIZER for engineering, STARTER for commissioning					
High-performance single-motor drives		High-performance multi-motor drives			
Continuous motion control / motion control / positioning tasks in production machines, e.g. packaging, textile, printing, paper, plastics machines, plants and process lines, presses; converting applications; numeric control applications in machine tools					
D 21.4	D 21.4	D 21.4	D 21.4, NC 62	D 21.4, NC 62	D 21.4

<sup>1</sup> Blocksize devices and Booksize devices: for a 4 kHz pulse frequency. Chassis units, Cabinet Modules: for a 2 kHz pulse frequency  
Observe the dependency between the max. output frequency and the pulse frequency as well as the current derating.

<sup>2</sup> With four liquid-cooled, vector control Motor Modules connected in parallel

<sup>3</sup> With liquid-cooled Motor Modules

**There 's more to it**  
[siemens.com/ids](http://siemens.com/ids)

**Discover in detail how  
Integrated Drive Systems boost  
your competitive edge and  
improve your time to profit.**

Integrated  
Drive Systems  
to go: Visit our  
mobile website



**Follow us on:**  
[www.twitter.com/siemensindustry](https://www.twitter.com/siemensindustry)  
[www.youtube.com/siemens](https://www.youtube.com/siemens)

**Published by  
Siemens AG 2016**

Digital Factory  
P.O. Box 31 80  
91050 Erlangen, Germany

Subject to change without prior notice  
Article No. E20001-A30-P670-V6-7600  
Printed in Germany  
Dispo 21500  
WÜ/1000173743 WS 11162.0

The information provided in this brochure contains merely general descriptions or characteristics of performance which in case of actual use do not always apply as described or which may change as a result of further development of the products. An obligation to provide the respective characteristics shall only exist if expressly agreed in the terms of contract. All product designations may be trademarks or product names of Siemens AG or supplier companies whose use by third parties for their own purposes could violate the rights of the owners.

To secure plants, systems and machines as well as networks against cyber attacks, a holistic industrial security concept must be implemented (and continuously updated) corresponding to current state-of-the-art technology. Products and solutions from Siemens are just one component of such a concept.  
You can find additional information about industrial security at [siemens.com/industrialsecurity](http://siemens.com/industrialsecurity)